



ATTENTION:

VERY IMPORTANT

Before unloading and unpacking the machine perform a thorough inspection of the machine and report any suspected shipping damage to the freight carrier. Also, after unwrapping the machine a thorough inspection of the electrical conduits and connections should be made to check for damaged components.

Failure to do so may result in the forfeiture of the warranty.

m44
OWNER'S
MANUAL

Orion Packaging Inc.
4263 Richelieu
Montreal H4C 1A1
Tel.: 514-937-6642

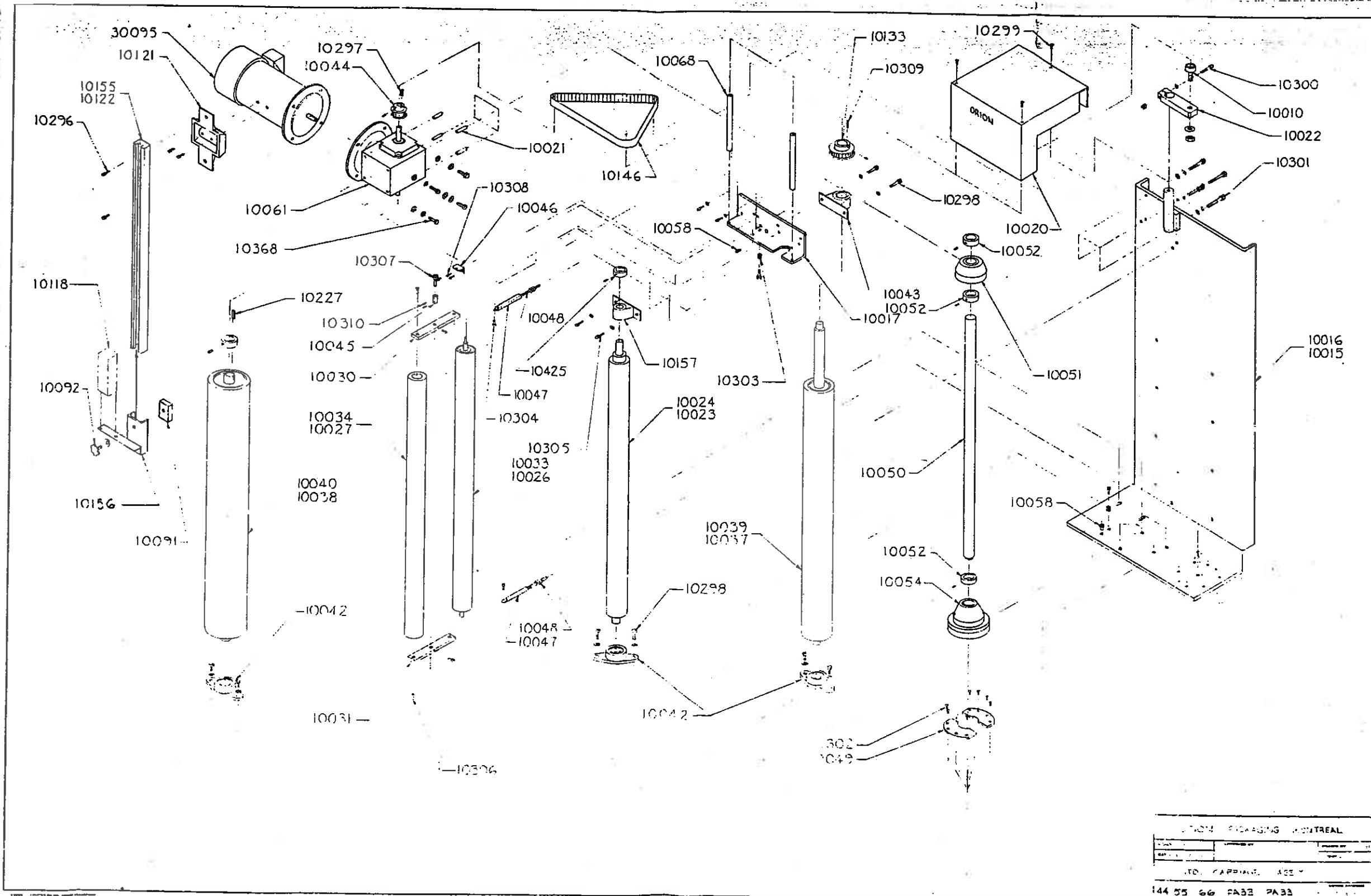

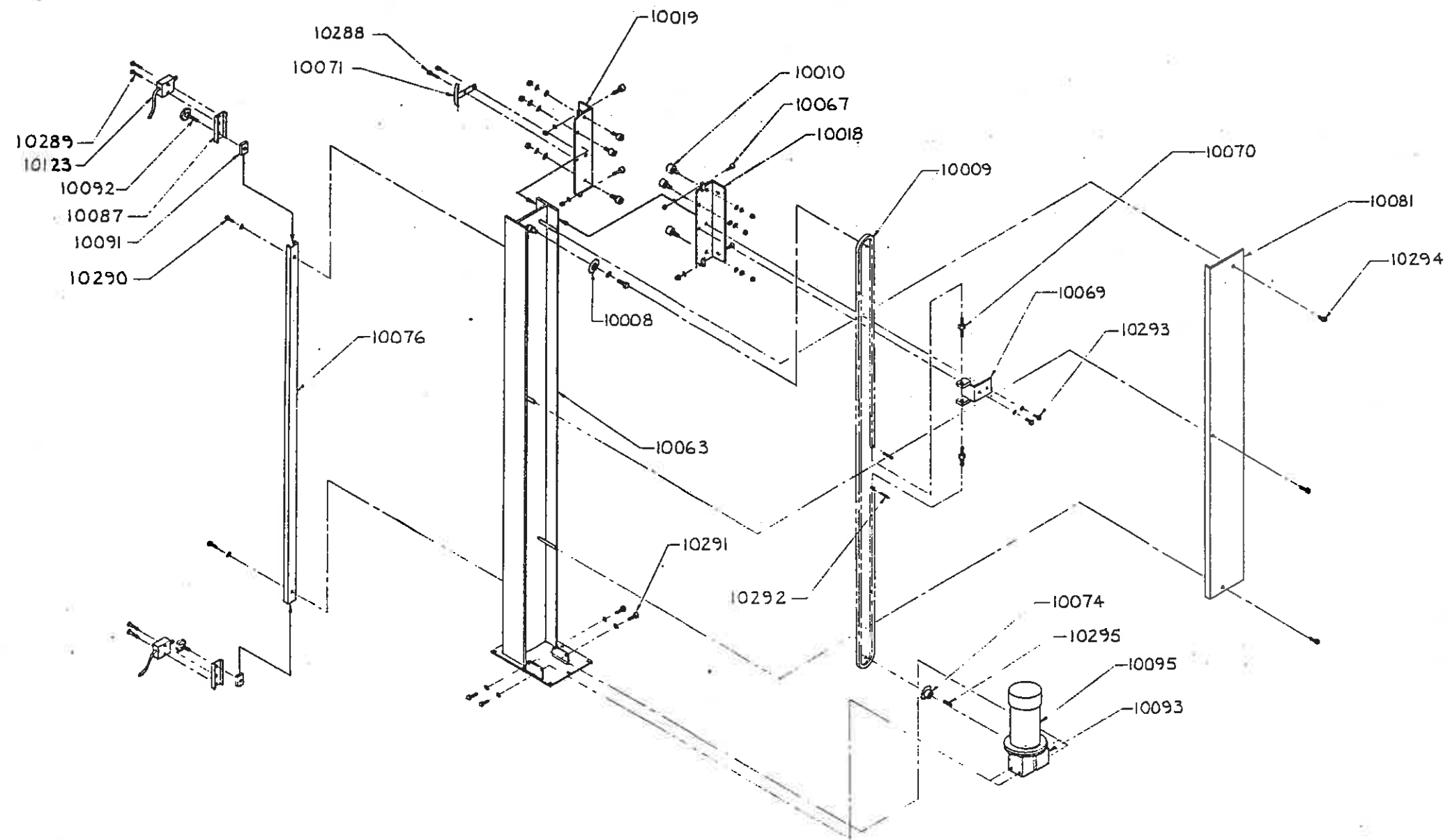

ORION PACKAGING MONTREAL		
Scale: N.T.S.	Drawn by: [blank]	Checked by: [blank]
Date: 27-6-66	Part No: [blank]	Quantity: [blank]
STD. TOWER ASSY		
44 H44 55 H55 PA33	200-59	[blank]

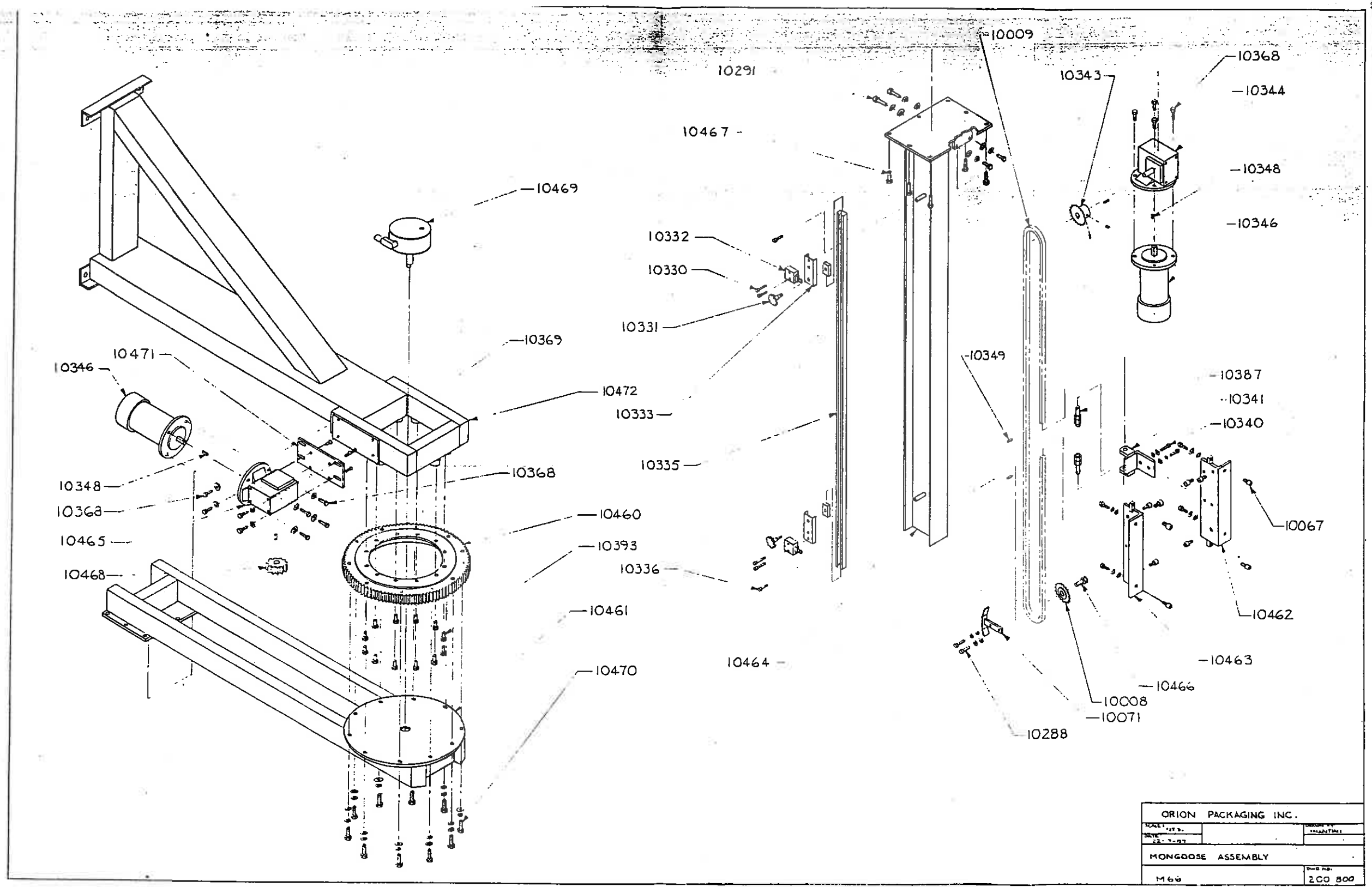

ORION PACKAGING INC.	
SCALE: 1/4" = 1"	DATE: 7-27-57
MONGOOSE ASSEMBLY	
M 66	2 CO 800

TABLE OF CONTENTS

TITLE	PAGE
1. M 44 SPECIFICATIONS	1
2. STANDARD FEATURES	2
3. OPTIONS	3
4. RECOMMENDED SPARE PARTS LIST	4
5. MANUAL CONTROLS	5
5.1 Power Switches	6
5.2 Operation Mode Selector Switch	6
5.3 Conveyor Control Switches	6
5.4 Carriage Control Switches	7
5.5 Stop Switch	7
5.6 Clamp Jog	7
5.7 Rewrap Selector	8
6. CYCLE ADJUSTMENT CONTROLS	
6.1 Film Tension	9
6.2 Carriage Speed	9
6.3 Top And Bottom Wraps	10
7. MACHINE MONITORING SWITCHES	
7.1 Photoswitches	11
7.2 Limit Switches	11
7.3 Proximity Switch	11

8. MACHINE MAINTENANCE

8.1 Speed Reducer Maintenance	12
8.2 Ring Gear Maintenance	13
8.3 Motor Maintenance	13
8.4 Chain Maintenance	14
8.5 Cam Follower Maintenance	14

APPENDIX	15
----------	----

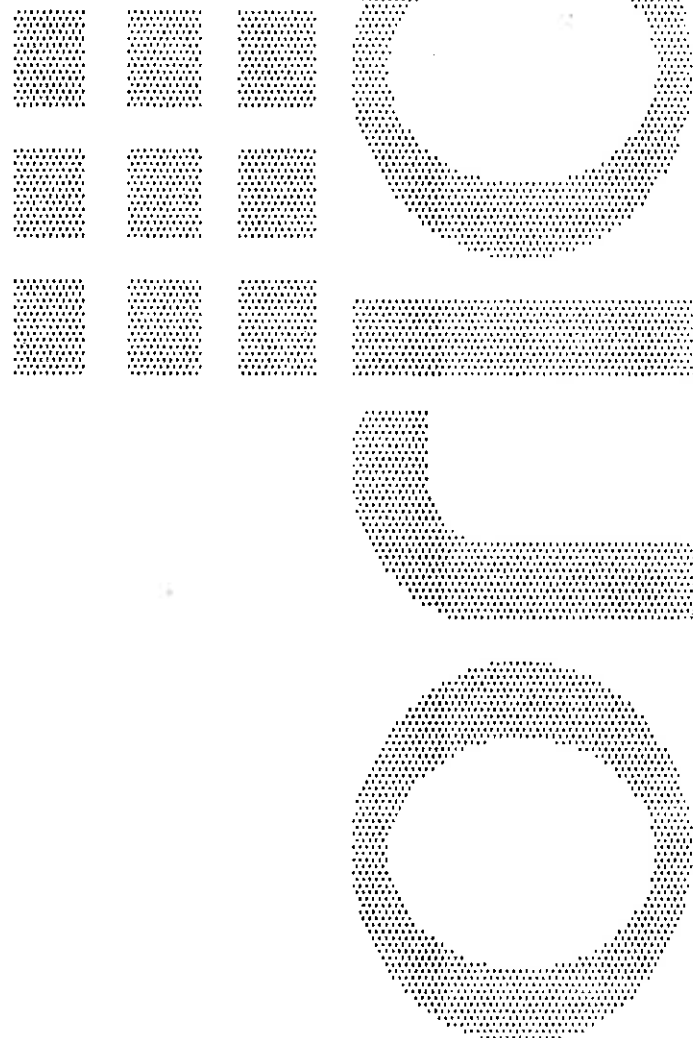

1. M44 SPECIFICATIONS

Power requirements: 240 VAC, 60 Hz, 30 A, 3 phase

Maximum wrap diameter: 76 inches

Rotor drive motor: 1 hp, 1750 rpm, 180 VDC, TEFC

Elevator motor: 1/2 hp, 1750 rpm, 90 VDC, TEFC

Elevator speed control: 25 fpm max.

Multistretch motor: 1/2 hp, 1750 rpm, 90 VDC, TEFC

Maximum pallet load dimensions: 53" width x 53" length x 80" height

Minimum pallet load dimensions: 30" width x 30" length x (30" or 20") height

Load output: 60 loads per hour

Film roll: 20" or 30" wide

Film delivery: Multistretch I prestretch system with a dancer bar that controls the "force to load" compensation.

Dust tight controls.

2. STANDARD FEATURES

The M44 Mongoose stretchwrapper comes with,

- Heavy duty structural steel chassis,
- Multistretch I prestretch system,
- Ring gear mounted rotor

The carriage height is controlled by a variable speed, SCR controlled, DC motor, with an automatic load height sensor and a broken film detector.

The variable speed rotor is directly driven by a right-angle, worm and gear speed reducer, and an external ring gear (slewing ring). The rotor has a variable speed of up to a maximum of 20 RPM with a dynamic braking system.

The Multistretch I prestretch system has the capability of varying its prestretch through the use of change timing belt pulleys which are available through your Orion representative.

The stretchwrapper is compatible with all major brands of film.

3.

OPTIONS

Power requirements:

575 VAC, 60 Hz, 3 phase, 30 Amps

or 440 VAC, 60 Hz, 3 phase, 25 Amps

or 240 VAC, 60 Hz, 3 phase, 20 Amps

Carriage for 20" film.

Carriage for 30" film.

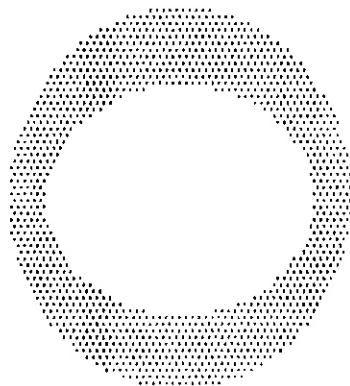
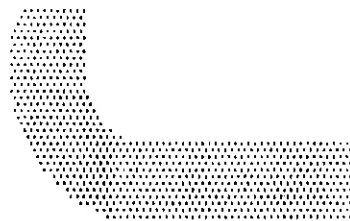
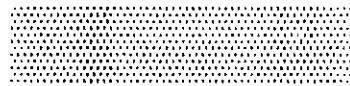
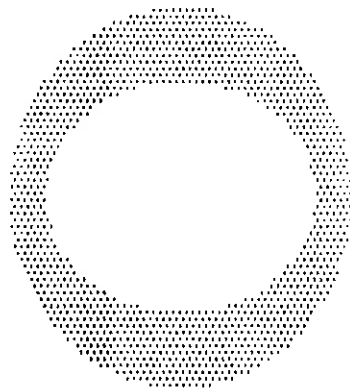
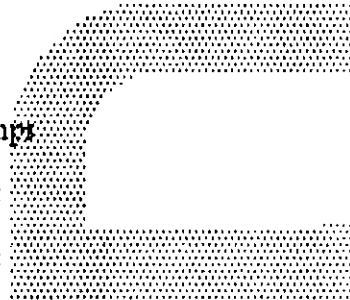
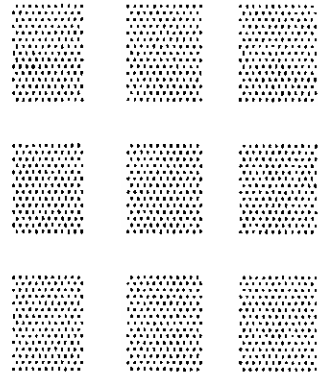

4. RECOMMENDED SPARE PARTS LIST

Part Description	Drawing Number
Carriage:	
4" diameter rubber roller	10040
3" diameter rubber roller	10039
Reducer, BQ 133, 5:1	10061
Motor, 1/2 hp, 90 VDC	30095
3/4" flanged bearing unit	10042
3/4" pillow block	10157
1" pillow block	10043
Note: For the carriage spare parts order please specify whether the carriage holds 20" film or 30" film.	
Tower:	
Reducer, BQ 175, 40:1	10093
Motor, 1/2 hp, 1750 rpm, 90 VDC	10095
Sprocket, 40 B 19	10074
Sprocket with bronze bushing 40 B 11	10008
Roller drive chain #50	10009
Rotating arm (rotor):	
Elevator cable spring	10047
Spur gear, 19T, 8mm module, 20°	10489
Reducer, BQ 262, 15:1	10490
Motor, 1 hp, 1750 rpm, 180 VDC	10485
Flat electrical cable	10491

5. MANUAL CONTROLS AND START-UP

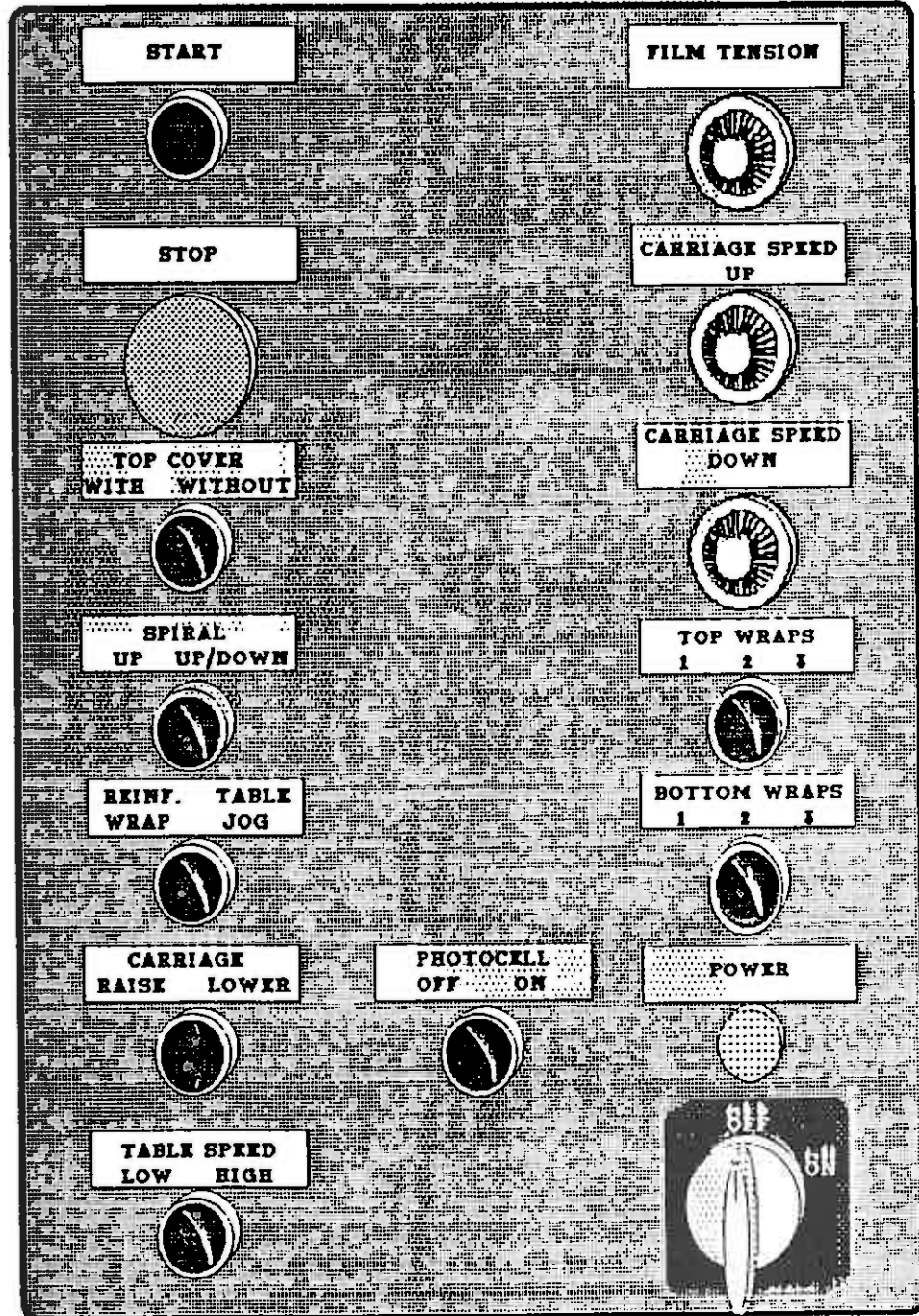

5.1 Power Switch

The Power Switch has two settings,

ON - Connects a 110 VAC power source to the machine,

OFF - Disconnects the power source.

Turning the power switch ON causes the POWER light to turn on.

5.2 Start And Stop Switches

The Start switch is used to start the cycle once the load is in position under the rotor. Once started the cycle may be stopped at any time by pressing the Stop button.

NOTE: if the Stop button is pressed in the middle of the cycle, the rotor must be returned back to its home positions before restarting the cycle.

5.3 Top Cover Switch

The Top Cover switch has two positions,

WITH - In the WITH position the cycle will stop after one top wrap is completed, allowing the placement of a top sheet on the load, after which the start button may be pressed to resume wrapping.

WITHOUT - In the WITHOUT position the cycle will not pause for the placement of a top cover.

5.4 Spiral Wrap Switch

The Spiral Wrap switch has two positions,

UP - In the UP position the cycle will end after completing the specified number of top wraps, therefore, the machine will only wrap the load once, going up.

UP/DOWN - In the UP/DOWN position the cycle is complete after the load is wrapped in both the up and down directions.

5.5 Reinf. Wrap/Rotor Jog Switch

This switch has three positions,

Middle position - in this position the switch is inactive and the machine will operate normally.

Reinf. Wrap - when the switch is held in this position during operation the carriage will stop rising or descending in order to increase the number of wraps around the chosen section.

Table Jog - when the switch is held in this position the rotor will turn in a clockwise direction as viewed from the top. The rotor jog is inoperative during the wrap cycle.

5.6 Carriage Control Switch

The Carriage Control switch is a monostable three position switch with the following settings,

RAISE - Raises the carriage until the top limit switch on the tower is activated or until the photoswitch senses that the carriage has reached the top of the load.

LOWER - Lowers the carriage until the bottom limit switch on the tower is activated.

The switch is normally in the middle position where the carriage remains stationary. Turning the switch to the RAISE or LOWER position will activate the carriage to move in its respective direction.

5.8 Photocell Switch

The Photocell switch has two settings,

ON - When turned ON, the photocell senses whether or not the carriage has reached the top of the load. The carriage will stop and begin the top wrap sequence once the top of the load is reached. The carriage will always stop at the top of the load regardless of its height. The photocell's position on the track can be adjusted in order to make the carriage pass the top of the load and overlap the top.

OFF - When turned OFF, the photocell is inoperative and the carriage will stop only once the top limit switch has been activated.

6. CYCLE ADJUSTMENT CONTROLS

6.1 Film Tension

The film tension may be adjusted through the film tension control potentiometer. The pot has a range of tension from 0 to 10, 10 being the highest tension rating. This pot may be adjusted during the automatic cycle or when the Operation Selector switch is set to AUTO.

CAUTION: Light loads may require lower tension settings than heavier loads.

The film tension is controlled through the dancer bar system. Occasionally the feedback potentiometer may need some adjustment. The adjustment of the feedback potentiometer can be performed while there is no film on the carriage. The bottom screw on the potentiometer coupling must first be loosened. Once the screw is loosened the potentiometer shaft must be turned until the prestretch motor just begins to hum but does not rotate, at which point the screw can be tightened. **NOTE:** the condition in which the motor hums but doesn't turn must be maintained even after the screw is tightened, if not, the adjustment procedure must be repeated.

6.2 Carriage Speed

There are two carriage speed controls on the panel.

CARRIAGE SPEED UP,
CARRIAGE SPEED DOWN.

The carriage speed controls can be used to control the amount of overlap the film will have on itself during a wrap. It is recommended to start with a RAPID upward wrap in order to stabilize the load early in

the cycle.

The control potentiometers have settings from 0 to 10, the higher settings being the fastest. High settings will mean less film overlap because of faster carriage speed, and low settings will mean more film overlap because of lower carriage speeds.

6.3 Top And Bottom Wraps

There are two bistable, three position, switches which control the number of wraps that may be put at the top and bottom of the load,

TOP WRAPS - 1, 2, 3

BOTTOM WRAPS - 1, 2, 3

These switches may be set before the cycle begins, and in their different positions will wrap respectively 1, 2, or 3 turns of film on the top or bottom of the load.

7. MACHINE MONITORING SWITCHES

7.1 Photoswitches

A photoswitch is used to sense whether the top of the load has been reached by the carriage. This switch is located on the carriage and stops the carriage from moving higher than the highest point on the load. The photoswitch's position on the track can be adjusted in order to make the carriage pass the top of the load by up to 12 inches.

7.2 Limit Switches

There are two limit switches located on the tower. These switches limit the motion of the carriage to that determined by the location of the elevator's drive and idler sprockets. The limit switches may be readjusted if necessary to limit the carriage to a shorter length of travel but never to one that will make the carriage collide with the floor of the elevator sprockets.

CAUTION: These limit switches are factory adjusted and, unless they have been disturbed, should not need any further adjustment.

7.3 Proximity Switch

The only proximity switch is located on the overhead beam, above the rotor. Its purpose is to monitor the rotor's position and the number of turns it does. The proximity switch's proper adjustment ensures that the rotor will stop in the correct position after every cycle.

NOTE: The proximity switch is factory adjusted and should not need any further adjustment unless it has been disturbed.

8. MACHINE MAINTENANCE

8.1 Speed Reducer Maintenance

On the reducing transmission, after the first week all external cap screws and plugs should be checked for tightness. It is recommended to change the oil every six months or every 2500 hours of operation, whichever comes first. When adding oil the transmission should never be filled above the oil level mark indicated because leakage and overheating may occur. Below is a list of the type of lubricant that should be used.

Manufacturer	Lubricant
American Oil Co.	American Cyl. Oil No. 196-L
Cities Service Oil Co.	Citgo Cyl. Oil 180-5
Gulf Oil Corp.	Gulf Senate 155
Mobile Oil Corp.	Mobil 600 W Super Cyl. Oil
Phillips Oil Co.	Andes S 180
Texaco Inc.	624-650T Cyl. Oil
Shell Oil Co.	Valvata Oil J82
Union Oil Of Cal.	Red Line Worm Gear Lube 140

Reducing transmissions are found over the rotor's ring gear, on the carriage, and at the base of the tower.

8.2 Ring Gear Maintenance

The ring gear is located on the overhead beam and should be lubricated at fixed intervals. This should be carried out by injecting grease into all the lubrication nipples in succession until a collar of fresh grease appears around the perimeter of both sealing rings. The bearing could be rotated slowly during lubrication.

The relubrication interval depends on the operating conditions. For bearings exposed to an aggressive environment, relubrication should occur every 50 operating hours. Normally, relubrication should occur every 100 to 200 hours of operation. The gear teeth should also be relubricated. Lubricants of different manufacture recommended for the ring gear are shown below.

Manufacturer	Raceway Grease	Gearteeth Oil
BP	Energrease LS 2	Energol WRL
Castrol	Spherol AP 2	Grippa 33 S
ESSO	Beacon 2	Surret Fluid 30
Gulf	Crown Grease No.2	Lubcote No.2
Mobil	Mobilux 2	Mobiltac E
SHELL	Alvania Grease B 2	Cardium Compound C/Fluid C
Texaco	Glissando FT 2	Crater 2 X Fluid
Valvoline	LB-2	FGC

8.3 Motor Maintenance

An occasional inspection of the brushes should be made in order to establish a wear rate. Replace-

ment brushes should be installed before old brushes wear to 9/16" long, measured on the long side. After replacing brushes run the motor near rated speed for at least 1/2 hour with no load to seat the new brushes. Failure to properly seat the new brushes may cause commutator damage and rapid wear of the new brushes. If the commutator becomes rough, scored, or out of round, a competent motor shop should disassemble the motor and resurface the commutator. With every third brush change, have a competent motor shop resurface the commutator and blow the carbon dust out of the motor.

8.4 Chain Maintenance

To clean and relubricate chains, wipe them with an oily cloth every month. If the environment is very dusty or damp, it may be necessary to clean and relubricate the chains more often.

With time the elevator chain will tend to stretch. A loose elevator chain should be tightened at the chain tensioner as shown on drawing number 200 192.

8.5 Cam Follower Maintenance

The cam followers behind the carriage, on the tower, have deep grease pockets and need not frequent relubrication.

The portion of the tower on which the cam follower roll should be cleaned and relubricated every 300 hours of operation. If the machine operates in an aggressive or corrosive environment the tower should be cleaned and relubricated more often.

APPENDIX

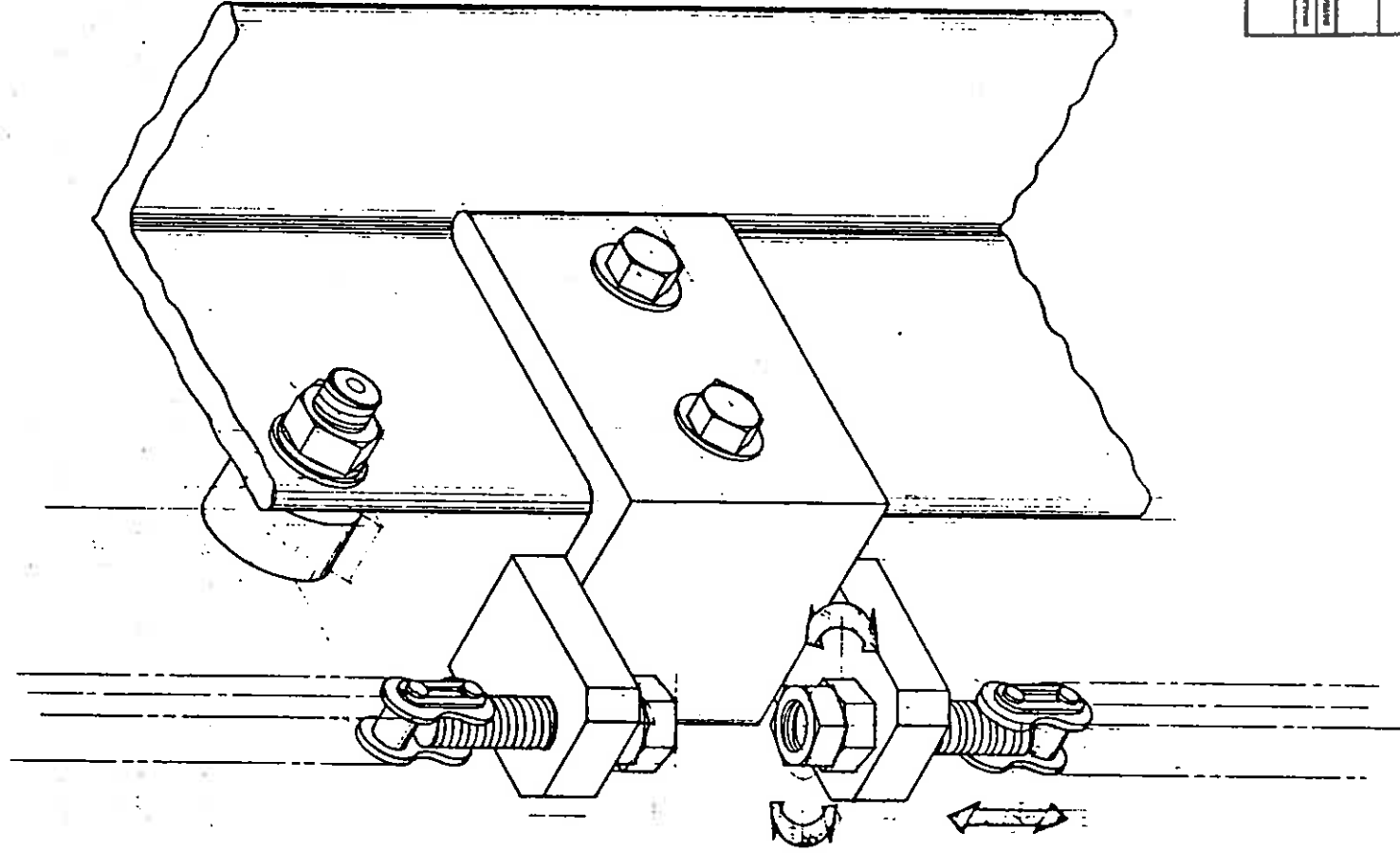

CHAIN TENSION
ADJUSTMENT

ORION PACKAGING	
MODEL: N.T.S.	APPROVED BY:
DATE: 10-7-86	DESIGNED BY:
CHAIN TENSIONER ASS'Y	
PART NUMBER: 200-192	

Lubrication

REDUCERS MAY BE FILLED TO THE PROPER LEVEL AT THE FACTORY WITH AGMA No. 8 compounded oil. AFTER INSTALLATION OF THE BREATHER PLUG, UNIT IS READY FOR USE. Before installing breather plug, refer to instruction tag and determine proper position according to reducer mounting.

We recommend an initial oil change after 250 hours of operation, then every six months or every 2500 hours of service under Class I Service. If fluctuating temperatures, humid, dirty or corrosive environment, oil changes should be made more frequently. Frequency can be established by oil sample analysis.

KEEP YOUR OIL CLEAN



Doerr Electric replacement oil

To order oil, request:

Doerr part no. 00019001 — synthetic AGMA #7EP
(-40°F to 150°F)

Doerr part no. 00019101 — AGMA #8 (50°F to 125°F)

Oil is packed 12 one quart bottles per carton, minimum ship one carton.
Contact DEC Service Dept. for order information.

OIL CAPACITIES*

UNIT TYPE	UNIT SERIES				
	133	175	200	282	325
Worm Over	14	20	27	49	84
Worm Under	17	22	28	49	73
Vertical Output	10	15	20	37	63
"J" Mount	13	18	23	38	63

*Capacities in approximate ounces. On double reduction units determine capacity of both primary and secondary reducers.

OIL LEVELS*

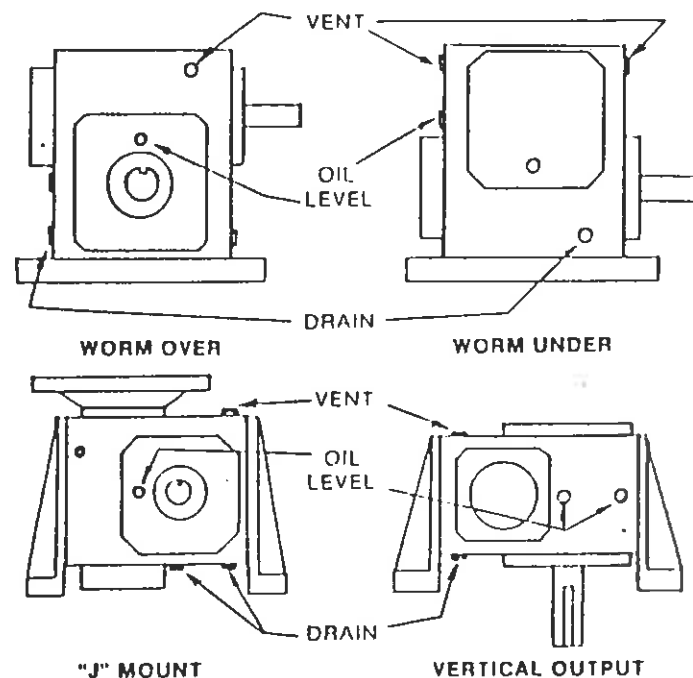

*On double reduction units fill and vent each unit to levels shown.

Motor dimensions

TEFC P/M motor

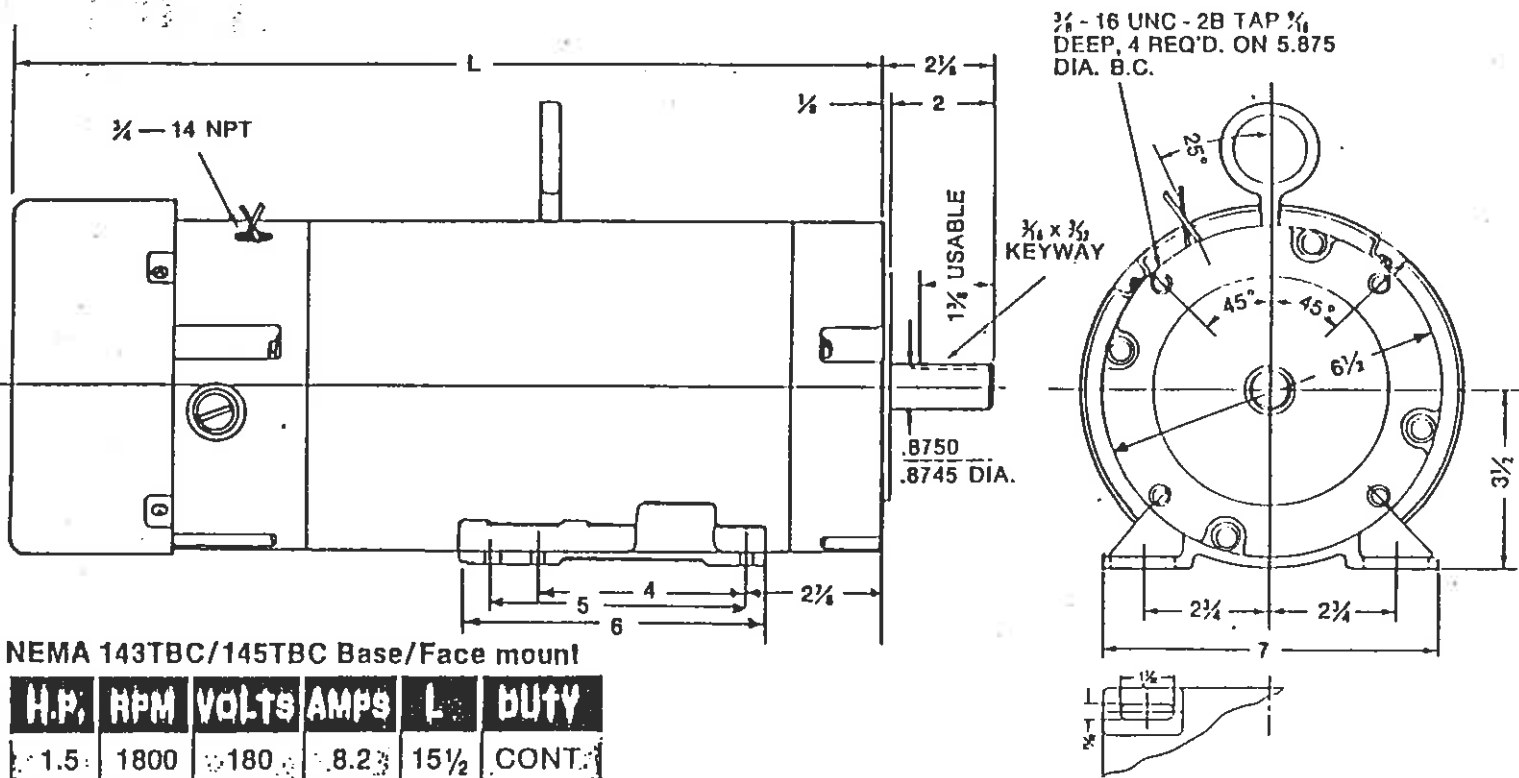

NEMA 143TBC/145TBC Base/Face mount

H.P.	RPM	VOLTS	AMPS	L	DUTY
1.5	1800	180	8.2	15 $\frac{1}{2}$	CONT.
2	1800	180	11.6	16 $\frac{1}{2}$	CONT.

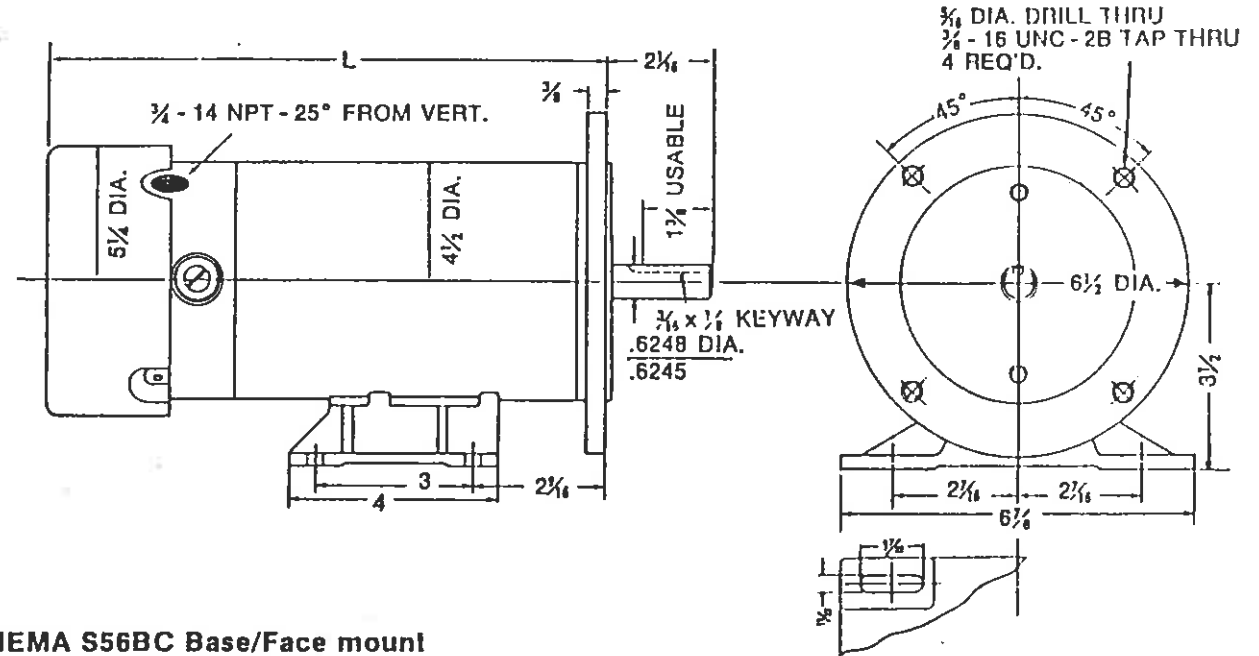

NEMA S56BC Base/Face mount

180 V.

H.P.	RPM	VOLTS	AMPS	L	DUTY
$\frac{1}{2}$	1725	180	2.8	10 $\frac{3}{4}$	CONT.
$\frac{3}{4}$	1725	180	3.5	12 $\frac{3}{4}$	CONT.
1	1725	180	5.35	14 $\frac{3}{4}$	CONT.

90 V.

H.P.	RPM	VOLTS	AMPS	L	DUTY
$\frac{1}{2}$	1725	90	5.35	10 $\frac{3}{4}$	CONT.
$\frac{3}{4}$	1725	90	8.1	12 $\frac{3}{4}$	CONT.
1	1725	90	10.6	14 $\frac{3}{4}$	CONT.



MAINTENANCE INSTRUCTIONS

STANDARD REDUCERS SERIES 133, 175, 206, 262, 325

INDEX

	Page
Introduction	1
Equipment Required	1
General Instructions	1
Housings	1
Seals	1
To Change Output Shaft Direction	1
Unit Disassembly, Parts Service, and Reassembly	1
Disassembly	1
Low Speed Shaft Removal	1
High Speed Shaft Removal	1, 2
Parts Service	2
Housing	2
Seal Cages and End Cover	2
Air Vent	2
Seals	2, 3
Bearings	3
Worm Gear and Shaft	3
Unit Reassembly	4
High Speed Shaft Assembly	4
Low Speed Shaft Assembly	4
Preventive Maintenance	6
Stored and Inactive Units	6
Parts Ordering Instructions	6
Exploded Views	7, 8, 9
Parts List	9
Warranty	Back Cover

MAINTENANCE INSTRUCTIONS FOR STANDARD REDUCERS

Series 133, 175, 206, 262 and 325

INTRODUCTION

The following instructions apply to standard Worm Gear Reducers. When ordering parts or requesting information specify all information stamped on the reducer nameplate. The nameplate will also identify the type of lubricant to be used.

EQUIPMENT REQUIRED

In addition to standard mechanic's tools, the following equipment is required: arbor press, wheel puller, torque wrench, dial indicator, seal driver, bluing, Permatex No. 2 and Permatex No. 3, snap ring pliers for internal and external rings.

GENERAL INSTRUCTIONS

Housings — Clean external surfaces of reducer before removing seal cages and end covers to prevent dirt from falling into the unit. Record mounting dimensions of accessories for reference when reassembling. If it is necessary to remove the reducer from its operating area, disconnect all connected equipment and lift reducer from its foundation.

Seals — Replacement of all seals is recommended when a unit is disassembled. However, if seals are not to be replaced, protect seal life by wrapping shaft with thin, strong paper coated with oil or grease before removing or replacing seal case assembly. Clean the shaft but do not use any abrasive material on the shaft surface polished by the seal.

CAUTION

If the reducer is painted, extreme care should be taken to mask the shaft extensions and rubber surface of the seals. Paint on the shaft adjacent to the seal or on the seal lip will cause oil leakage.

TO CHANGE OUTPUT SHAFT DIRECTION

To change the hand of a unit from left hand to right hand, or vice versa, the following instructions apply:

1. Remove drain plug and drain oil from unit.
2. Remove end cover and seal cage cap screws; then while supporting output shaft remove end cover and shims from the unit.
3. Remove output shaft and seal cage together from extension side.

NOTE: Keep shims with their respective seal cage and end cover.

4. Insert seal cage, shims and sub-assembly into the housing from the side opposite from which they were removed. Insert seal cage cap screws and tighten with light pressure.
5. Assemble end cover and shims. Insert end cover cap screws and tighten with light pressure.
6. Turn high speed shaft in both directions to see that gear train is running freely.
7. Cross tighten seal cage and end cover cap screws to torques listed in Table 1.

TABLE 1. CAPSCREW TIGHTENING TORQUE

Capscrew Diameter	1/4 - 20 UNC	5/16 - 18 UNC	3/8 - 16 UNC
Torque (in. lbs.) Dry	96	204	360

UNIT DISASSEMBLY, PARTS SERVICE, AND ASSEMBLY

Disassembly:

1. Remove drain plug and drain oil from unit.
2. Low speed shaft (gear shaft) removal:
 - A. Remove end cover and seal cage cap screws.
 - B. With a firm hold on the output extension remove end cover and shims.
 - C. Carefully slide output shaft assembly and seal cage out extension side.
 - D. Slide seal cage off low speed shaft using caution to prevent damage to seal lips.
 - E. Wire or tie the shims to their mating end cover and seal cages. They will be available for reference when assembling the unit.
3. High speed shaft (worm shaft) removal:
 - A. Position unit with input shaft down. With a small chisel make a groove in the stamped steel cover opposite the shaft extension. Pry cover off.

- B. Remove internal snap ring from housing bore.
- C. Reposition the housing with the worm shaft horizontal. Using a plastic hammer gently tap on the end of the shaft extension to feed worm shaft assembly through housing and out.

Parts Service:

- 1. **Housing** — Clean inside of housing with kerosene or solvent and then dry.
- 2. **Seal cages and end cover** — Remove dirt from joint faces, wipe clean and dry.
- 3. **Air vent** — Wash in kerosene, blow clean and dry.
- 4. **Seals** — To replace seals without dismantling reducer refer to steps C through F below. To replace seals when the entire reducer is dismantled and coupling hubs, sprockets, pulleys, pinions, keys, etc. have been removed the following instructions apply:

NOTE: Replacement of all seals is recommended when a unit is disassembled.

Caution

New seals will leak if the seal lips or if seal's rubbing surface on the shaft has been altered. Protect seal lips at all times. Clean the shaft but do not use any abrasive material on the shaft surface polished by the seal.

- A. Block up seal cages and press or drive out seal.
- B. Remove old sealing compound from seal seat in cage if it is present. If a seal with rubber coating on the outside diameter is used, no Permatex is necessary. If no rubber coating is on seal outside diameter, coat seal cage bore with Permatex No. 3 or equivalent immediately before assembly.
To prevent possible damage to seal lips, do not reassemble seals until high speed and low speed shafts have been reassembled to the housing. Then see steps E and F below.
- C. See Figures 1 through 4—To replace seals without dismantling reducer, proceed as follows:

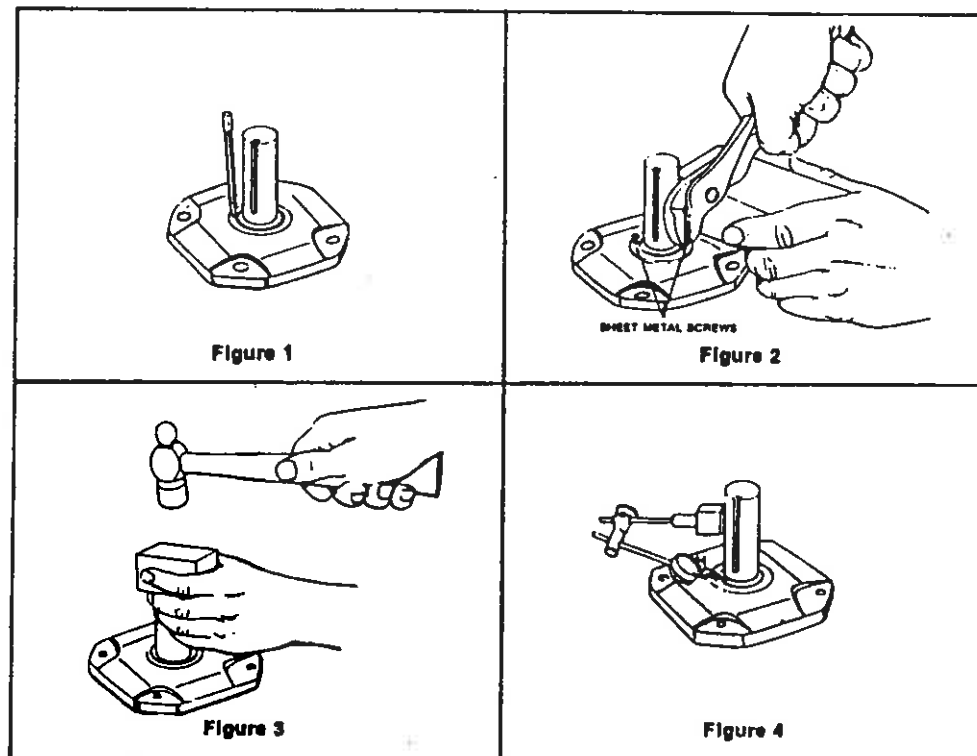

Caution

Do not damage shaft; new seals will leak if seal contacting surface is marred. Use punch and place two or more holes in steel casing of seal, Figure 1. (The steel casing may be rubber coated) Insert sheet metal screws, leaving the heads sufficiently exposed so they can be pried up or grasped with pliers, Figure 2. Do not drill holes because chips may get into the unit.

- D. Work seal loose. Be careful to keep all metal or dirt particles from entering unit. Remove old sealing compound from seal seat if it is present. Also remove burrs and sharp edges from shaft. Clean with rag moistened with solvent. Do not use abrasive material on shaft seal contacting surface.

Caution

E. Protect seal lips when handling; seal leakage will result if these are damaged. If a seal with rubber coating on the outside diameter (O.D.) is used, no Permatex is necessary. If no rubber coating is on seal O.D., coat seal cage bore with Permatex No. 3 or equivalent. Coat seal lips with oil and carefully work seal into position. Before sliding seal into position, protect seal lips from shaft keyway edges by wrapping shaft with thin, strong paper coated with oil. Position garter spring toward the inside of the unit. Place a square faced pipe or tube against the seal O.D. and drive or press seal until fully seated as shown in Figure 3. Do not strike seal directly.

- F. For best performance, seat the seal square with shaft within .005" at 180°. Check with dial indicator as shown in Figure 4, Page 2, or with a straight edge and feelers, or square and feelers. To straighten a cocked seal, place tubing over the seal and tap the tube lightly at a point diametrically opposite the low point on the seal. DO NOT strike seal directly.

5. Bearings —

- A. Wash all bearings in clean kerosene and then dry.
B. Inspect bearings carefully and replace those that are worn or questionable.
NOTE: Replacement of all bearings is recommended.
C. Use a wheel puller or press to remove worm shaft bearings. Apply force to inner race only — not to cage or outer race.
D. Use a wheel puller or press to remove output bearing inner races.
E. New seal cages and end covers must be used when replacing output bearings. Output bearing outer races must be pressed in square and seated completely.
F. To replace output bearing inner races and all input bearings, heat bearings in an oil bath or oven to maximum of 290 degrees F (143 degrees C). Slide high speed shaft bearings onto the oiled shaft until seated against the shoulder or snap ring of the shaft. Slide low speed shaft bearings onto the oiled shaft against the gear spacer.
G. Thoroughly coat all bearings with lubricating oil.

6. Worm, gear and shafts

- A. Worm and high speed shaft—since all worms are integral with the high speed shaft, any wear or damage to the worm will necessitate replacing both.
B. Press shaft out of bronze worm gear. To reassemble gear and low speed shaft, freeze shaft or heat gear. Do not exceed 200 degrees F (93 degrees C). Insert key into shaft keyway and press shaft into oiled gear bore. The short hub of the gear must be assembled toward snap ring on the shaft.
NOTE: It is advisable to replace both the worm and worm gear should either of the assemblies require replacement.

Unit Reassembly:

1. Preliminary

- A. Check to see that all worn parts have been replaced, gear and bearings coated with oil and all parts cleaned. Remove all foreign matter from unit feet. The feet must be flat and square with each other.
- B. Before starting to reassemble reducer, add old shims or replace with new shims of equal thickness.

2. High Speed Shaft (Worm Shaft) Assembly

- A. Lubricate bearing bores of housing and insert high speed shaft sub-assembly from opposite extension end into housing until seated against shoulder in bore. Tap the end of the shaft lightly with a plastic hammer to feed bearings through bores.
- B. Lock high speed sub-assembly in housing bore with lock ring.
- C. Coat outside diameter of stamped steel end cover with Permatex No. 2 and press into high speed bore opposite extension end until flush with housing. If steel endcover is rubber coated then no Permatex is necessary.

3. Low Speed Shaft (Gear Shaft) Assembly

- A. Determine output shaft direction.
- B. Assemble low speed shaft assembly, seal cage, and end cover with shims on both seal cage and end cover. Torque cap screws to torques listed in Table 1. Rotate the input shaft to seat output bearings.
- C. Moving the shaft back and forth by hand, check axial float with dial indicator as shown in Figure 5. Axial float must be .0005-.003 with .0005 being the absolute minimum. Do not preload bearings. If the axial float is not as specified add or subtract required shims under end cover.

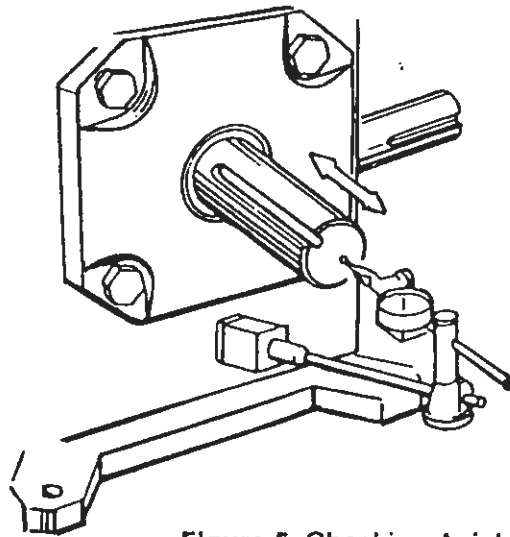

Figure 5 Checking Axial Float

- D. Remove output shaft with seal cage and apply bluing to entire worm thread. Worm thread must be clean of oil. Reassemble output shaft and seal cage with output key facing up.
- E. Use a rag to apply hand pressure to the output shaft and rotate the high speed shaft until output key is down. Return output shaft to original position by reversing rotation. Remove output shaft and seal cage to inspect contact. Compare with Figure 6. If contact is not correct move assembly in the direction shown in Figure 6 by adding shims to the side to which the arrow points after removing them from the opposite side. Repeat steps D and E until contact pattern is correct.
- F. Recheck axial float with dial indicator.
- G. When contact pattern is correct tighten seal cage and end cover cap screws to torques listed in Table 1 page 1.

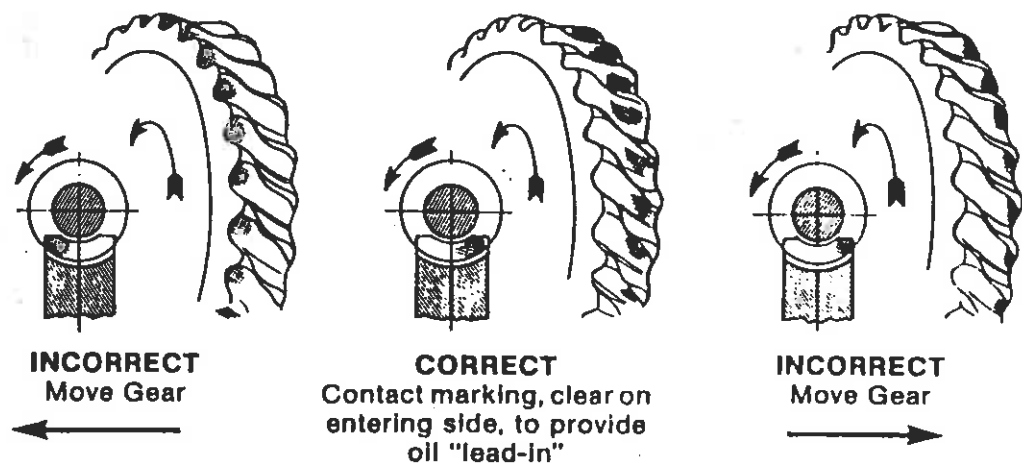

Figure 6 Gear Contact Pattern

4. **Seals** — To reassemble seals to unit, see Parts Service Steps 4E and 4F, page 3.

5. **Motorized Coupling Adapter**

Certain mounting dimensions should be adhered to when removing motor and coupling assembly for service. When ordering replacement coupling halves (metal gear), specify correct bore diameter. See Table 2 for mounting dimensions and available bore sizes.

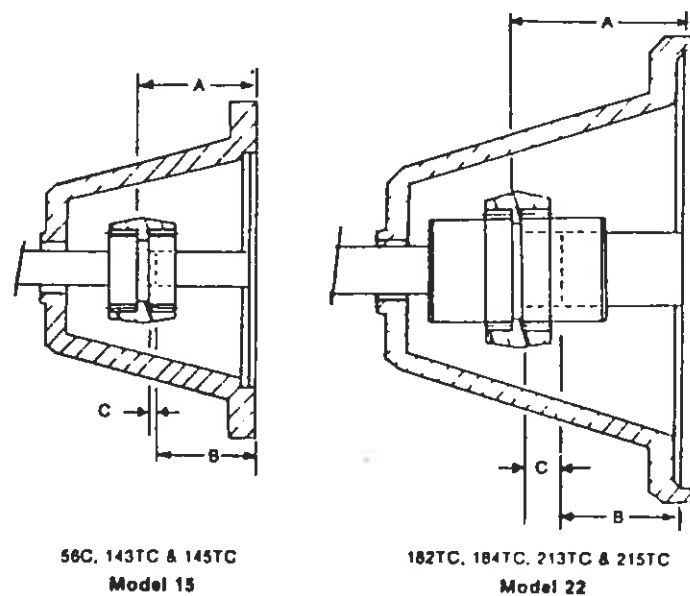

Figure 7 Motorized Coupling Adaptor

TABLE 2. COUPLING ADAPTOR DATA

"C" COUPLING MOUNTING DATA

N.E.M.A. Frame No.	Mounting Dimensions		
	Reducer A ± 1/64	Motor B ± 1/64	C
56C	2 1/16	2 1/16	1/16
143TC	2 1/16	2 1/8	—
145TC	2 1/16	2 1/8	—
182TC	3 1/16	2 5/8	1/2
184TC	3 1/16	2 5/8	1/2
213TC	3 1/16	3 1/8	—
215TC	3 1/16	3 1/8	—

BORE SIZES AVAILABLE

MODEL 15		MODEL 22	
Bore	Kwy.	Bore	Kwy.
.500	None	—	—
.500	1/8 x 1/16	—	—
.625	3/16 x 3/32	.625	3/16 x 3/32
.750	3/16 x 3/32	.750	3/16 x 3/32
.875	3/16 x 3/32	.875	3/16 x 3/32
—	—	1.125	1/4 x 1/8
—	—	1.375	3/16 x 3/32

6. Final Inspection

- A. Turn gear train over by hand as a final check.
- B. Re-install reducer and accessories.

CAUTION: Discard motor key. Use only special key provided with reducer. Failure to use special key will make assembly impossible.

- C. Fill reducer with the recommended oil to proper level. See Fig. 8 for standard oil levels. (Type of oil recommended — see nameplate).
- D. Spin test for three minutes and check for noise, leakage, and rapid temperature rise.

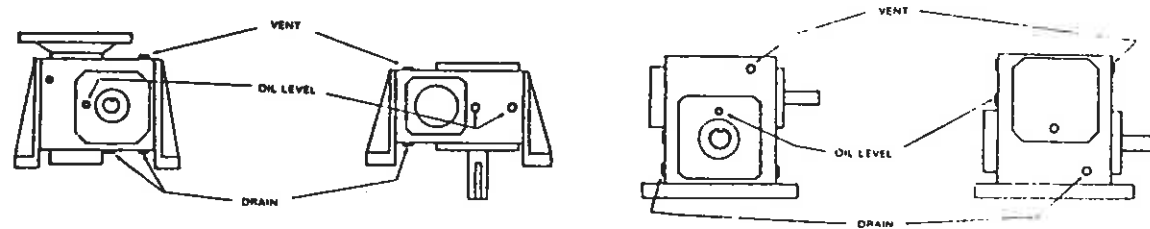

Figure 8 Standard Oil Levels

PREVENTATIVE MAINTENANCE

- A. After first week check all external cap screws and plugs for tightness.
- B. Periodically, check oil level when gears are at rest. Add oil if needed. Do not fill above mark indicated by level because leakage and overheating may occur.
- C. Oil changes — For normal operating conditions, change oil every six months or 2500 hours, whichever occurs first. Also if the unit is operated in an area where temperatures vary with the season, change the oil viscosity to suit the temperature. Most lubricant suppliers can test oil periodically and recommend economical oil change schedules.

CAUTION

See nameplate for type of lubricant to be used.

STORED AND INACTIVE UNITS

- 1. Each unit is shipped with oil that will protect parts against rust for a period of 4 months in an outdoor shelter or 12 months in a dry building after shipment from the factory. Indoor dry storage is recommended.
- 2. If a unit is to be stored or is to be inactive after installation beyond the above periods, fill the unit completely with oil.

CAUTION

Before starting a stored unit or re-starting an inactive unit, the oil level should be returned to the proper value as indicated by the oil level.

PARTS ORDERING INSTRUCTIONS

When ordering replacement parts first locate the exploded view that corresponds to your Doerr Electric gear reducer. Then determine which parts must be ordered. To order the parts, please provide the following:

- 1. Complete Model Number (Nameplate)
- 2. Item Number (Exploded view and parts list)
- 3. Part Description (Parts list)

Note that one parts list covers all five exploded views. Although a single item number may refer to the same part on all five exploded views, it is incorrect to assume that these parts are interchangeable. They are not. Therefore, it is imperative that items 1 through 3 above be provided when ordering your parts.

Failure to provide this information will only slow or prevent the processing of your order.

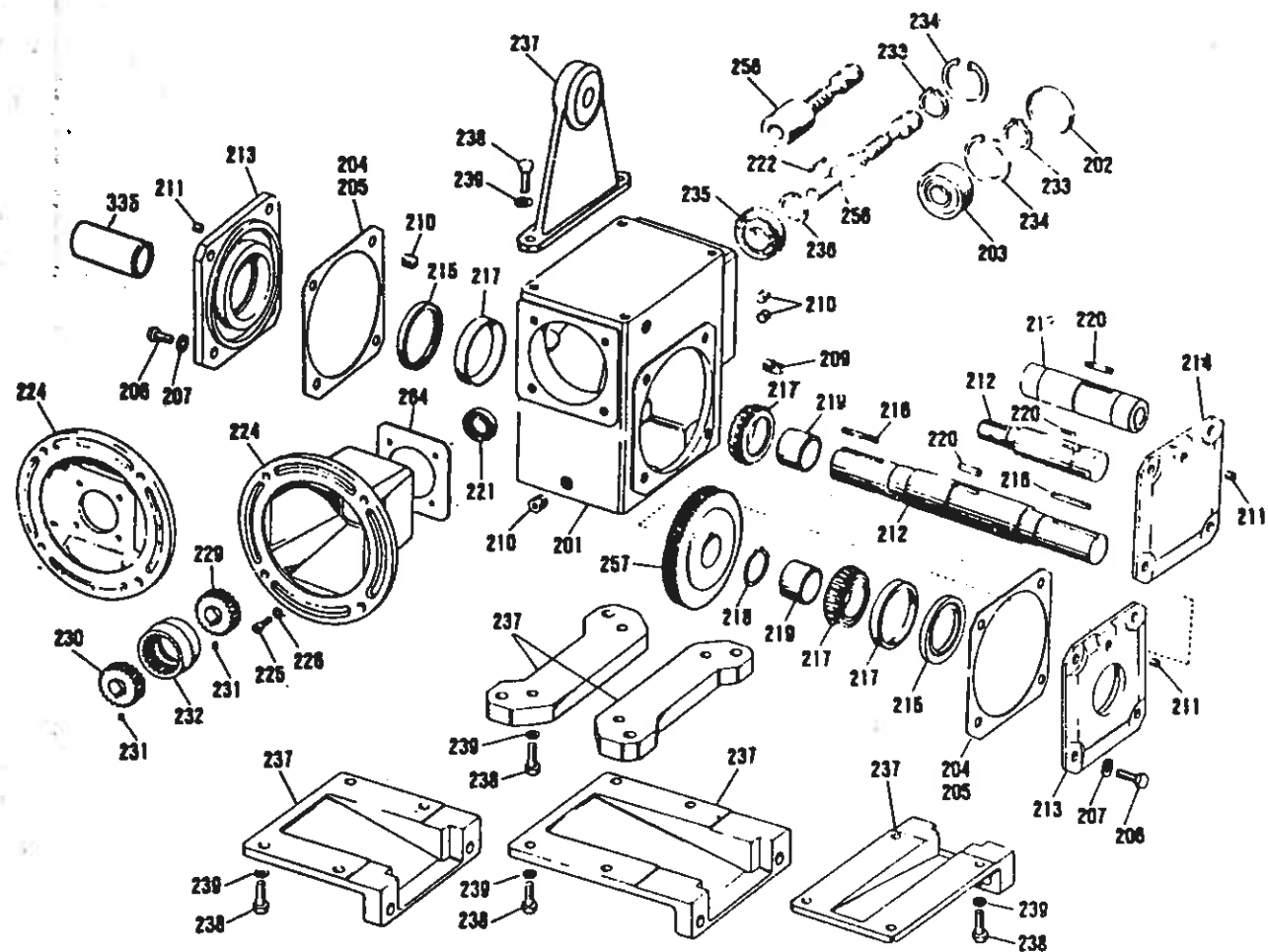

Single Reduction Unit 133, 175, 206 Series

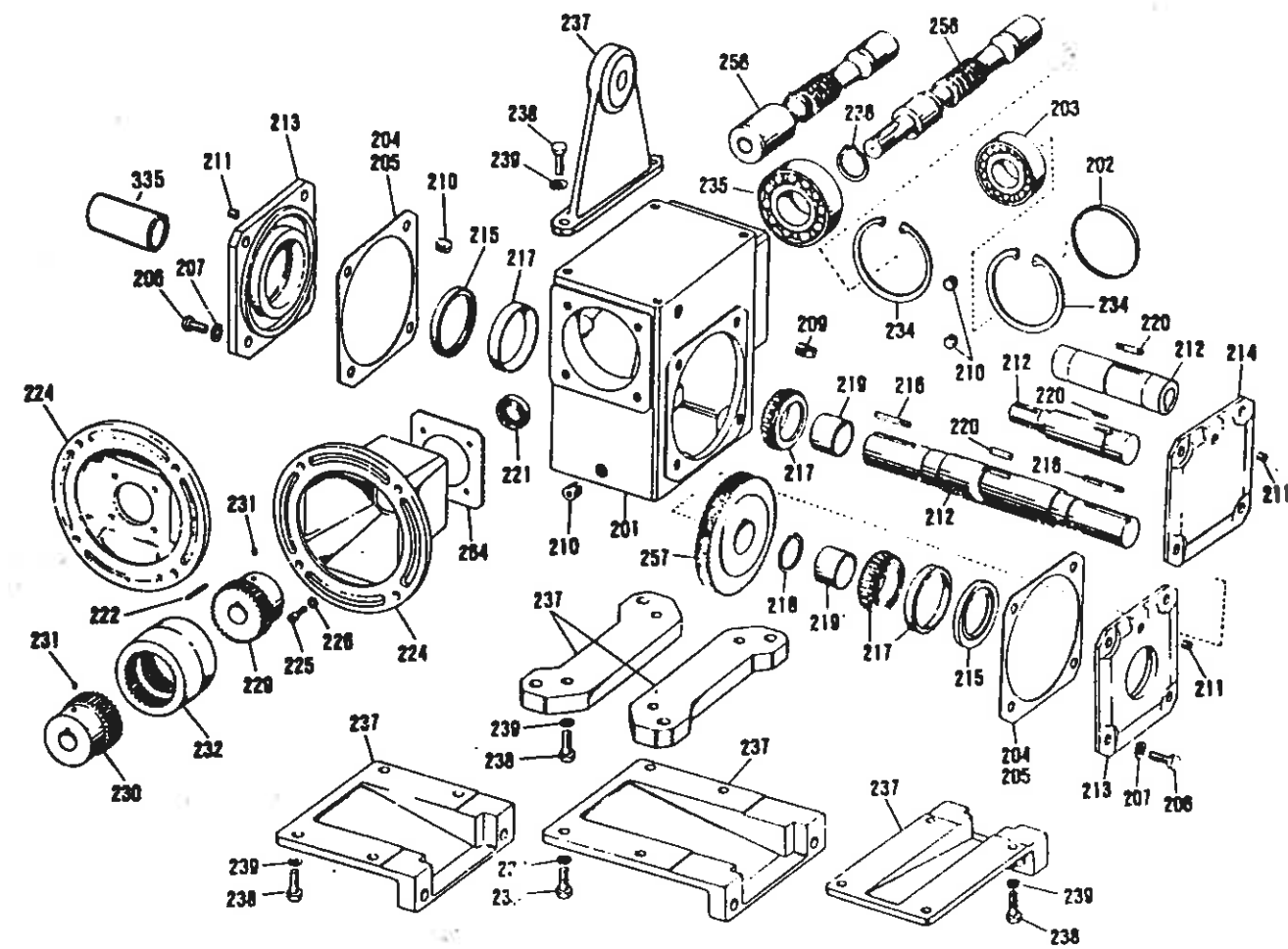

Single Reduction Unit 262, 325 Series

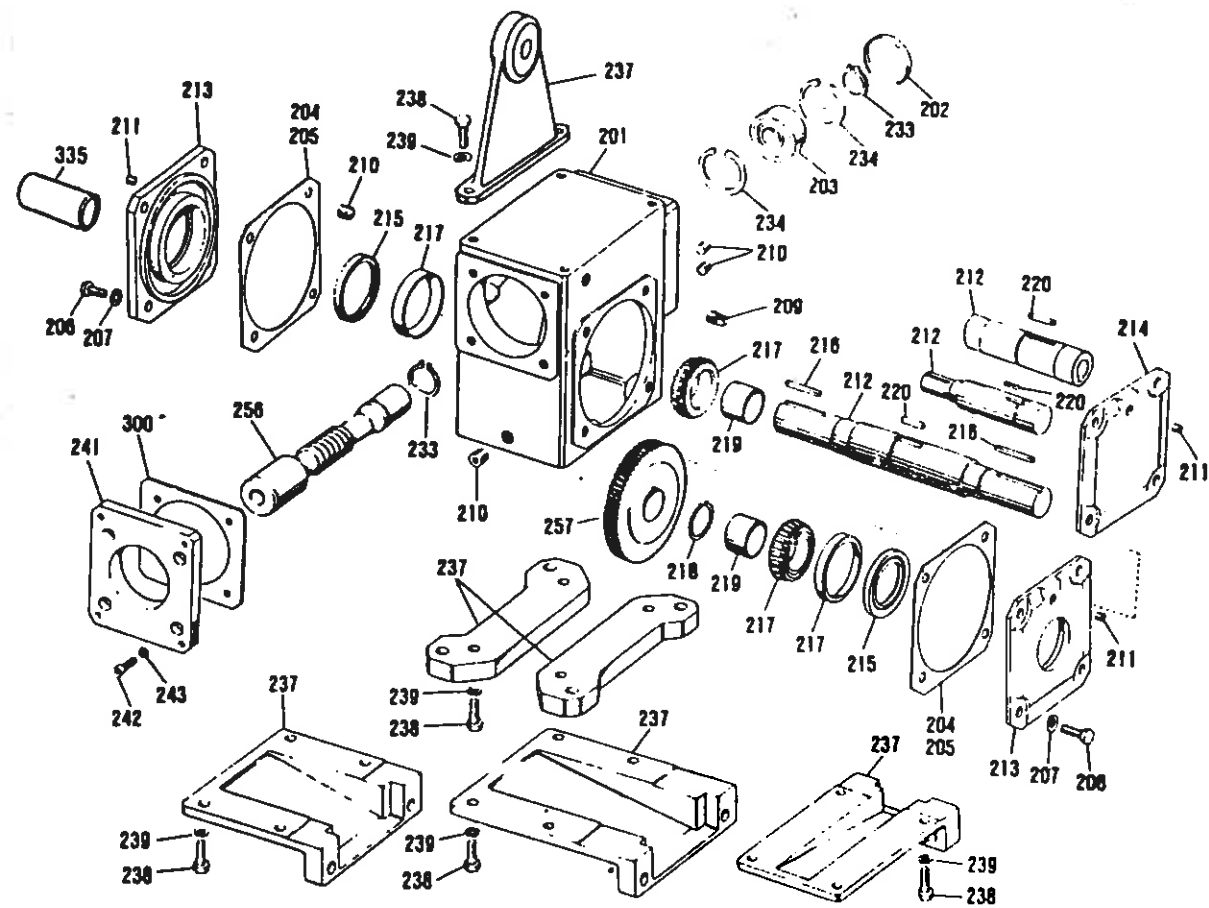

Double Reduction Secondary Unit 133, 175, 206 Series

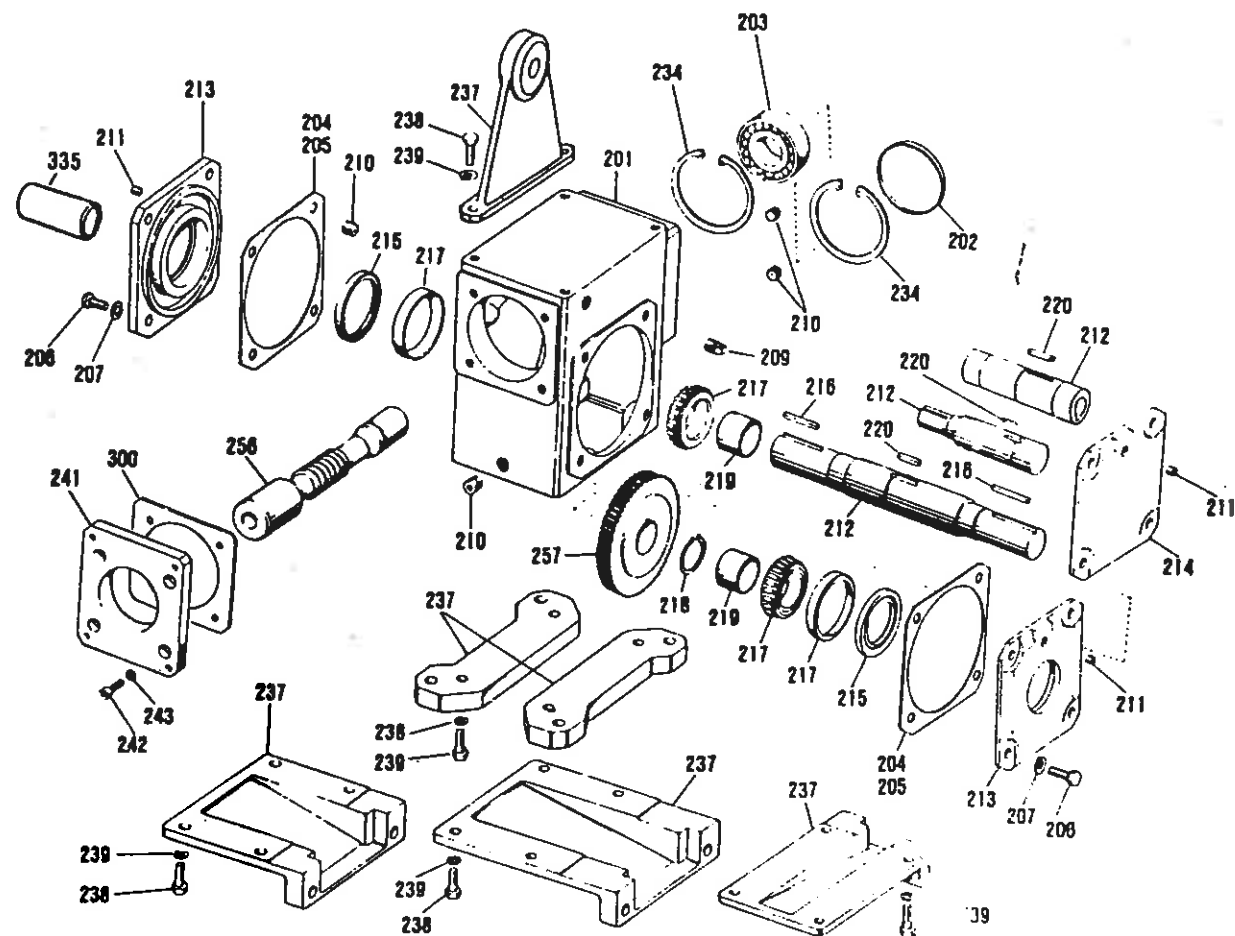

Double Reduction Secondary Unit 262, 325 Series

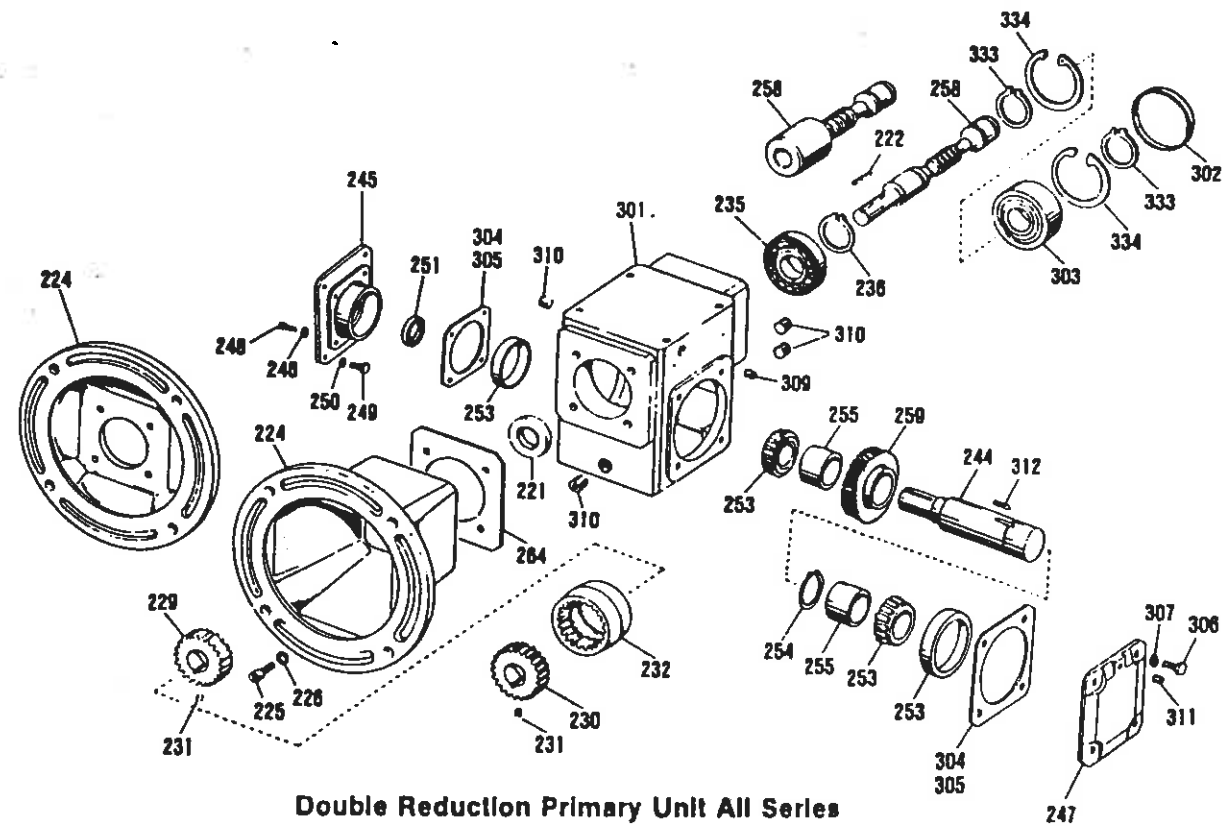

Double Reductlon Primary Unit All Series

PARTS LIST
(Applies to all exploded views)

ITEM	DESCRIPTION	ITEM	DESCRIPTION	ITEM	DESCRIPTION
201	Housing	229	Coupling Hub (Unit)	255	Spacer
202	End Cover	230	Coupling Hub (Motor)	256	Worm
203	Bearing	231	Setscrew	257	Gear
204	Shim (.019 Thick)	232	Coupling Sleeve	258	Worm
205	Shim (.007 Thick)	233	Lock Ring	259	Gear
206	Capscrew	234	Lock Ring	260	Thrust Plate
207	Lock Washer	235	Bearing	261	Capscrew
209	Vent Plug	236	Lock Ring	264	Gasket
210	Pipe Plug	237	Base	300	Gasket
211	Pipe Plug	238	Capscrew	301	Housing
212	Output Shaft	239	Lock Washer	302	End Cover
213	Seal Cage	241	Secondary Adaptor	303	Bearing
214	End Cover	242	Capscrew	304	Shim (.019 Thick)
215	Oil Seal	243	Lock Washer	305	Shim (.007 Thick)
216	Key	244	Primary Output Shaft	306	Capscrew
217	Bearing	245	Primary Adaptor	307	Lock Washer
218	Lock Ring	246	Lock Washer	309	Vent Plug
219	Spacer	247	End Cover	310	Pipe Plug
220	Key	248	Capscrew	311	Pipe Plug
221	Oil Seal	249	Capscrew	312	Key
222	Key	250	Lock Washer	333	Lock Ring
224	Motor Flange	251	Oil Seal	334	Lock Ring
225	Capscrew	253	Bearing	335	Shaft Cover
226	Lock Washer	254	Lock Ring		

Note: When ordering replacement parts, specify model number, item number, and part description.

Electrical Boards' Chart
for
ORION Stretchwrappers

	168-4	168-A	236	336	750+	750M-240W	850M	850C	155-3A
MLH 44 Processor	X		X		X				
MLH 44	X		X		X				X
MLH 55		X		X			X		X
MLH 66		X		X			X		X
MLH 77		X							X
PA 33	X			X	X				
FA 33	X			X		X		X	
MA 33	X			X		X		X	
MA 44	X			X	X			X	
MA 55	X			X			X	X	

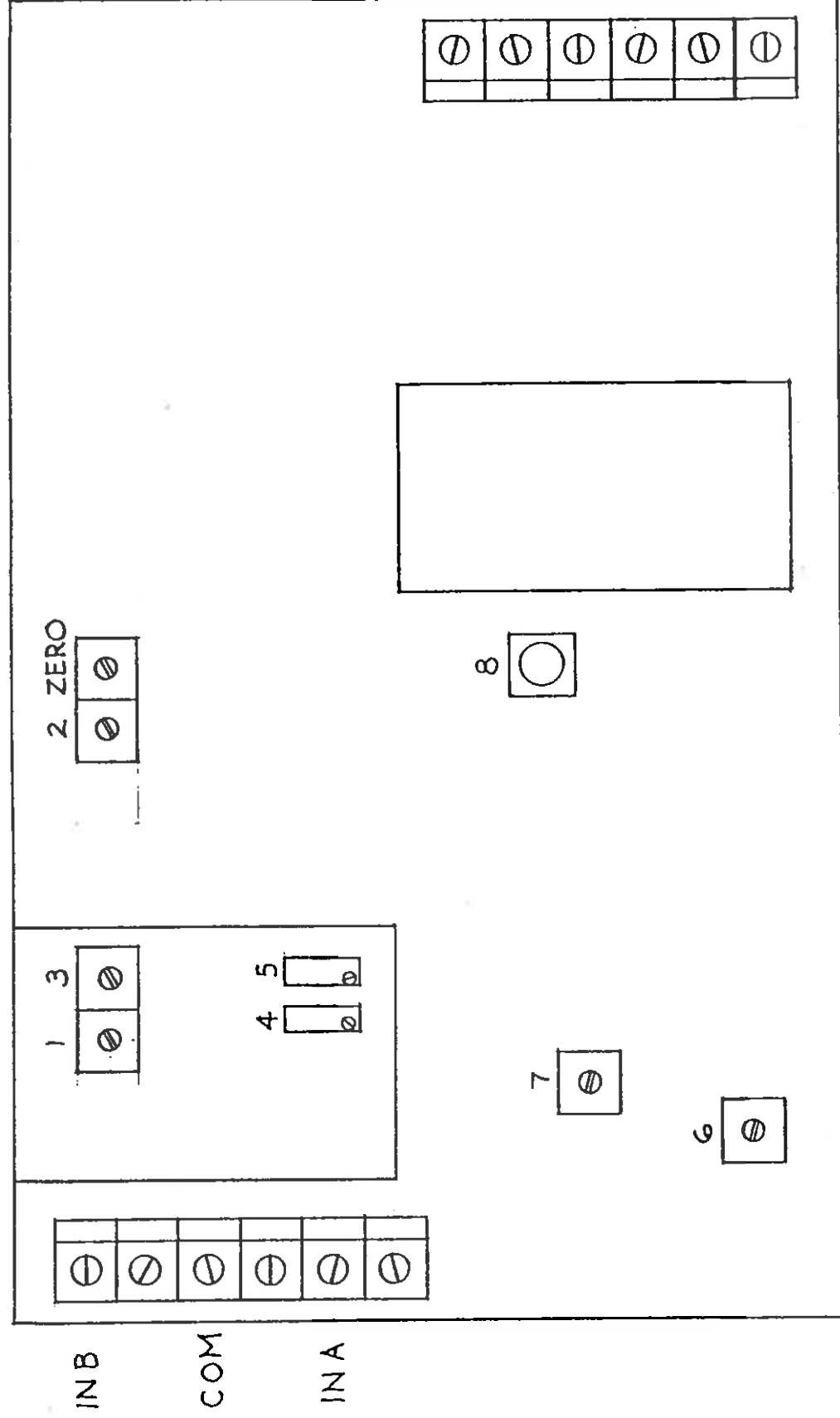

ZERO: TURNTABLE DEADBAND ADJ.

1: HIGH SPEED ADJ.

2: JOG SPEED ADJ.

3: LOW SPEED ADJ.

4: HIGH SPEED DECELERATION ADJ.

5: LOW SPEED DECELERATION ADJ.

6: ACCELERATION ADJ.

7: LOAD RANGE ADJ.

8: CURRENT LIMITER

ORION PACKAGING INC.

ECHELLE: N.T.S. - APPROUVE PAR: APPROVED BY:

SCALE: DATE: 16 - 09 - 87

DESSINE PAR: VALETTINI

REVISE PAR: REVISED BY:

750M + 233

NUMERO DE DESSIN

DRAWING NUMBER

200 888

168-4	DC
DC +	
AC 2	
AC 1	
1	

ORION PACKAGING INC.

APPROUVE PAR:
APPROVED BY:

ESCHELLE:
SCALE: N.T.S.

DATE: 16-9-87

DESSINE PAR:
DRAWN BY: VALENTINI

REVISE PAR:
REVISED BY:

168-4

NUMERO DE DESSIN
DRAWING NUMBER
200 892