



ATTENTION:

VERY IMPORTANT

Before unloading and unpacking the machine, read section 5 of this manual for unloading and unpacking instructions.

Failure to do so may result in the forfeiture of the warranty.

ORION PACKAGING INC.

NOTICE

In order to acquire more information about custom make features of the machine; and to provide quicker service, the following information is required when making an inquiry for a machine:

- 1) Serial Number
- 2) Model Number
- 3) Subassembly-Part Location

ORION PACKAGING INC.

L-77

OWNER'S MANUAL

**ORION PACKAGING INC.
2270 Industrial
Laval, Quebec
H7S-1P9**

**Telephone: (514) 667-9769
Fax: (514) 667-6320**

ORION PACKAGING SYSTEMS, INC.
DISTRIBUTOR PRICE LIST - EFFECTIVE NOVEMBER 1, 1989

ORION MODEL L-77

Spiral Semi-Automatic Medium Duty Low Profile

Maximum Load Size	56"W x 56"L x 84"H (Recommended) 62"W x 62"L x 87"H (Theoretical)*
Weight Capacity	4,000 lbs. dynamic, 20,000 lbs. static
Utilities	115/1/60 15 Amp Electrical Service
Turntable	60" Diameter 3/8" Steel Plate Steel Cam Follower Support System Self Lubricating System with Reservoir 3" Height Floor to Top of Turntable
Turntable Drive	10 RPM Fixed Turntable Speed 1/3 HP AC Drive Motor #50 Roller Chain Drive with Tensioner Soft Start Clutch
Control Features	Electronic Film Force Control High/Low Brake Force Selection Separate Top and Bottom Wrap Selectors Variable Speed Film Carriage Control Film Carriage Raise/Lower Switch Turntable Jog Pushbutton Power On/Off Switch Current Overload Protection NEMA 12 Electrical Enclosure
Film Delivery	20" Orion EconoStretch Film Carriage Film Roll Diameter Compensation Electronic Film Tension Control Electromechanical Film Braking End of Cycle Film Force Release
Film Carriage Drive	#50 Roller Chain Carriage Lift 1/4 HP Elevator Drive Motor Variable Speed SCR Control Structural "H" Channel Guidance Precision Cam Follower Tracking
Structural Features	Forklift Portable Base Design Unique Steel Ring Cam Follower Support All Structural Steel Construction Film Roping Bar 8" x 18 lb.ft. "H" Channel Mast
Est. Shipping Weight	1,000 lbs.

*Theoretical is based upon removal of roping bar, and reflects the maximum film web height attainable

ORION PACKAGING INC.
DISTRIBUTOR PRICE LIST - EFFECTIVE NOVEMBER 1, 1989

SEMI-AUTOMATIC MACHINE OPTIONS

44 STYLE (Powered Roller Turntable)

76" Dia. Powered Roller TURNTABLE, Rollers.....
3.5" Dia. on 4.5" Centers, All Full Length
Driven. Includes 1/2 hp DC Drive, Adjust-
able Speed. Wall Tubing 3/16", Cast Iron
Pillow Blocks. (NOTE: H55/44 only, requires
RING GEAR OPTION)

55 STYLE (CONTOURED Powered Roller Conveyor)

5' Length CONTOURED Powered Roller Conveyor,.....
3.5" Dia. Rollers on 4.5" Centers, 50"
Effective Width, All Full Length Rollers
Driven. Includes 1/2 hp AC Drive, Non-
Reversing. Wall tubing 1/8"

44 STYLE (CONTOURED Powered Roller Conveyor)

5' Length CONTOURED Powered Roller Conveyor,.....
3.5" Dia. Rollers on 4.5" Centers, 52"
Effective Width, All Full Length Rollers
Driven, Cast Iron Pillow Blocks.
Includes 1/2 hp DC Drive, Variable
Speed, with Soft Start.

Automatic Sequencing, Logic and Photocell.....
For Powered Conveyor (Per Section) - Includes
Photocell PLC Input and Output/Program.

Turntable Mechanical Home Position Lock.....
(Pneumatic, Positive Lock)

ORION PACKAGING INC.
DISTRIBUTOR PRICE LIST - EFFECTIVE NOVEMBER 1, 1989

SEMI-AUTOMATIC MACHINE OPTIONS

COLD TEMPERATURE OPTIONS (-20 F)

Heated Control Enclosure, Silicon Rubber Wiring.....
and Special Lubricant in Reducers

CONVEYOR OPTIONS

IDLER ROLLER (NON-DRIVEN)

72" Dia. idler roller turntable for H66/55/44.....
(On H-66, requires ring gear option and
max. wt. 2,500 lbs) Rollers are 3.5" Dia.
on 4.5" centers, with manual brake.

72" Dia. idler roller turntable for L55S/44S.....
Rollers are 3.5" Dia. on 4.5" centers, with
manual brake.

Pneumatic Roller Brake for "L" Series.....

Pneumatic Roller Brake for "H" Series.....

5' Length CONTOURED Idler Roller Conveyor,.....
3.5" Dia. Rollers on 4.5" Centers, 50" Wide
Roller Face.

5' Length STRAIGHT Idler Roller Conveyor,.....
3.5" dia. rollers on 4.5" centers,
50" wide roller face.

POWERED ROLLER

55 STYLE (Powered Roller Turntable)

76" Dia. powered roller TURNTABLE, Rollers.....
rollers 3.5" dia. on 4.5" centers, all full
length driven. Includes 1/2 hp AC drive,
adjustable speed. Wall tubing 1/8"
(H55/44 only - requires ring gear option)

ORION PACKAGING INC.
DISTRIBUTOR PRICE LIST - EFFECTIVE NOVEMBER 1, 1989

SEMI-AUTOMATIC MACHINE OPTIONS

FILM CARRIAGE OPTIONS

- Double #60 Chain Carriage Lift.....
- 20" Multistretch Retrofit Carriage.....
(For Installation on Existing Machines)
- 30" Multistretch Retrofit Carriage.....
(For Installation on Existing Machines)
- 30" Multistretch Carriage Upgrade from 20".....
on H66/55/44 and L66/55/66.
- 30" Multistretch Carriage Upgrade from 20".....
on M66/55/44.
- 30" Econostretch Carriage Upgrade on 77
Series from 20".

ELECTRONIC SCALE PACKAGE OPTION

Includes Heavy Duty Load Cells Incorporated.....
into the Machine or Conveyor Frame, Protected
from Lateral Shock, and a Digital Display of
Load Weight, with RS-232C Port, Gross, Net
Tare, Zero.

NOTE: On L-77 and L-66 models, scale option
reduces machine capacity to 2500 lbs.,
unless base reinforcement option is
ordered.

Base Reinforcement on L-77 or L-66 models,.....
when 4000 lbs capacity is desired with
scale package.

ORION PACKAGING INC.
DISTRIBUTOR PRICE LIST - EFFECTIVE NOVEMBER 1, 1989

SEMI-AUTOMATIC MACHINE OPTIONS

PNEUMATIC TOP PLATENS

36" circular platen with 24" stroke.....
36" circular platen with 36" stroke.....

48" x 48" square platen with homing.....
device, and 36" stroke
48" x 48" square platen with homing.....
device, and 48" stroke

TRANSFORMER

To accept 430/60 or 575/60.....
For each additional conveyor section.....

DUAL TURNTABLE OPTION

L66.....
H66.....
L55/44.....
H55/44.....
L55S/44S.....

NOTE: Dual Turntable options includes second
turntable with all drive components &
controls, second auto-height photocell,
and table selector switch.

NOTE: When a ring gear/pinion gear turntable
drive is required, the cost of 2 ring
gear options must be added to the dual
turntable option price.

RING GEAR/PINION GEAR TURNTABLE DRIVE

H66....(20" DIA.).....
H55....(25" DIA.).....
H44....(33" DIA.).....

Central lubrication point for ring gear.....

ORION PACKAGING INC.
DISTRIBUTOR PRICE LIST - EFFECTIVE NOVEMBER 1, 1989

SEMI-AUTOMATIC MACHINE OPTIONS

PROGRAMMABLE LOGIC CONTROLLER OPTIONS

66/55 Series - Allen Bradley SLC-100.....
44 Series - Allen Bradley SLC-150.....
EEPROM ordered with machine.....
EEPROM ordered after shipping of the machine.....

CYCLE COUNTER (inside control panel).....

TURNTABLE OPTIONS

0-12 RPM Variable Speed Turntable Drive for.....
L/H 77 Models
0-12 RPM Variable Speed Turntable Drive with.....
Positive Alignment Feature for L/H 77 Models
10,000 lb Capacity (H55/44).....
8,000 lb Capacity (L55/44).....
10,000 lb Capacity (L55/44).....
Anti-Skid Surface.....
72" dia. round, 3/8" with 4" skirt (H55/44).....
72" dia. round, 1/2" (L44/44S, L55/55S).....
72" dia. round, 1/2" (L66).....
72" dia. round, 3/8" (L66).....
60" dia. round, 1/2" (L66/55/44).....
Reinforced Concentric Rings.....
Remote Pull Switch.....
Filler Plate (H77/66).....
Filler Plate (H55/44).....

PART LIST

FOR TOWER W6 x 12 ASSEMBLY

updated April-07-92

NO.	ORION PART NO.	DESCRIPTION	Q-TY
1.	010293	HEX HEAD SCREW	4
2.	011390	SPRING WASHER	4
3.	010986	REDUCER	1
4.	010545	ELECTR. MOTOR	1
5.	012049	PAN PHILL	3
6.	011393	SPRING WASHER	7
7.	012735	TOWER CHAIN COVER	1
8.	010009	CHAIN	1
9.	010094	SPROCKET	1
10.	010052	COLLAR	2
11.	010999	SPROCKET	1
12.	012737	TOWER	1
13.	012722	HEX HEAD SCREW	2
14.	012740	LIMIT SWITCH ACTUATOR	1
15.	012742	RIGHT CARRIAGE HOLDER	1
16.	012741	LEFT CARRIAGE HOLDER	1
17.	010387	CHAIN TENSION SCREW	2
18.	012723	HEX HEAD SCREW	4
19.	012724	SPRING WASHER	4
20.	012725	FLAT WASHER	4
21.	010092	KNOB	2
22.	010087	LIMIT SWITCH HOLDER	2
23.	011153	CHANNEL GUIDE	2
24.	012690	PAN PHILL	4
25.	010123	LIMIT SWITCH	2
26.	012726	HEX NUT	2
27.	012743	SPRING WASHER	4
28.	010257	SOCKET HEAD CAP SCREW	4
29.	012221	FLAT WASHER	2
30.	010335	LIMIT SWITCH CHANNEL	1

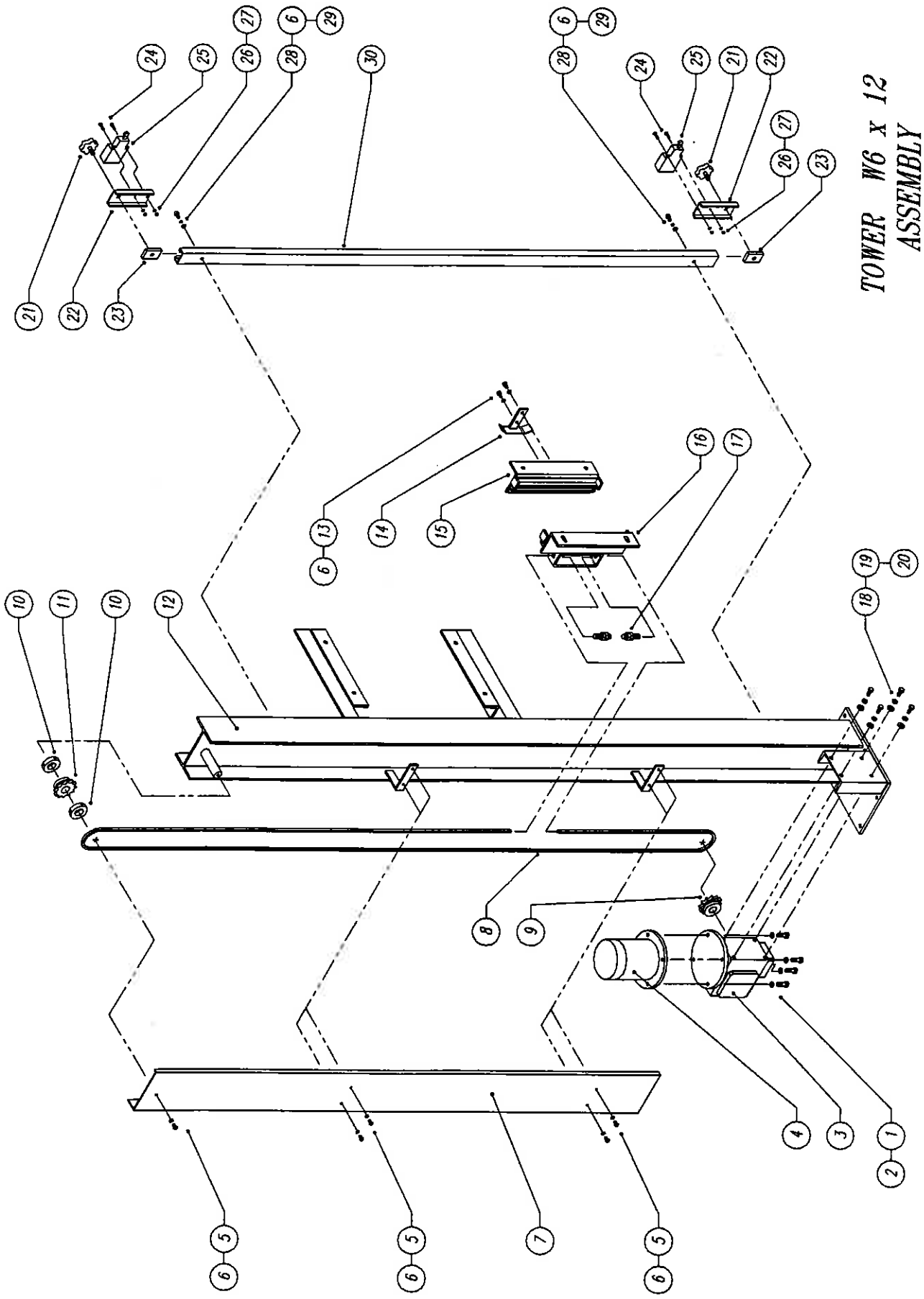

**TOWER W6 X 12
ASSEMBLY**

FOR L-77 & H-77

UPDATED APR-07-92

PART LIST

FOR LOW PROFILE L-77/7 BASE ASS'Y

updated Feb-14-92

ORION			
NO.	PART NO.	DESCRIPTION	Q-TY
1.	010293	HEX HEAD SCREW	11
2.	010007	CENTRAL BEARING UNIT	1
3.	010006	TURNTABLE SPROCKET	1
4.	012477	HEX NUT	5
5.	010898	PLATE	1
6.	012591	FLAT SOCKET CAP SCREW	1
7.	012596	TURNTABLE DISK	1
8.	010319	SOCKET HEAD CAP SCREW	4
9.	010329	HEX HEAD SCREW	1
10.	010008	IDLER SPROCKET	1
11.	012667	CHAIN TENSIONER	1
12.	010009	CHAIN	1
13.	010059	ELECTR. MOTOR	1
14.	010093	REDUCER	1
15.	010074	SPROCKET	1
16.	012049	PAN PHILL	2
17.	012599	CHAIN GUARD	1
18.	012594	ROPING BAR	1
19.	010382	HEX HEAD SCREW	4
20.	010233	CHAIN TENSION SCREW	1
21.	012647	PAN PHILL	2
22.	011322	HEX NUT	9
23.	012601	LOCK WASHER	9
24.	012598	CAM FOLLOWER	9

LOW PROFILE L-77/7 BASE ASSY
UPDATED FEB-14-92

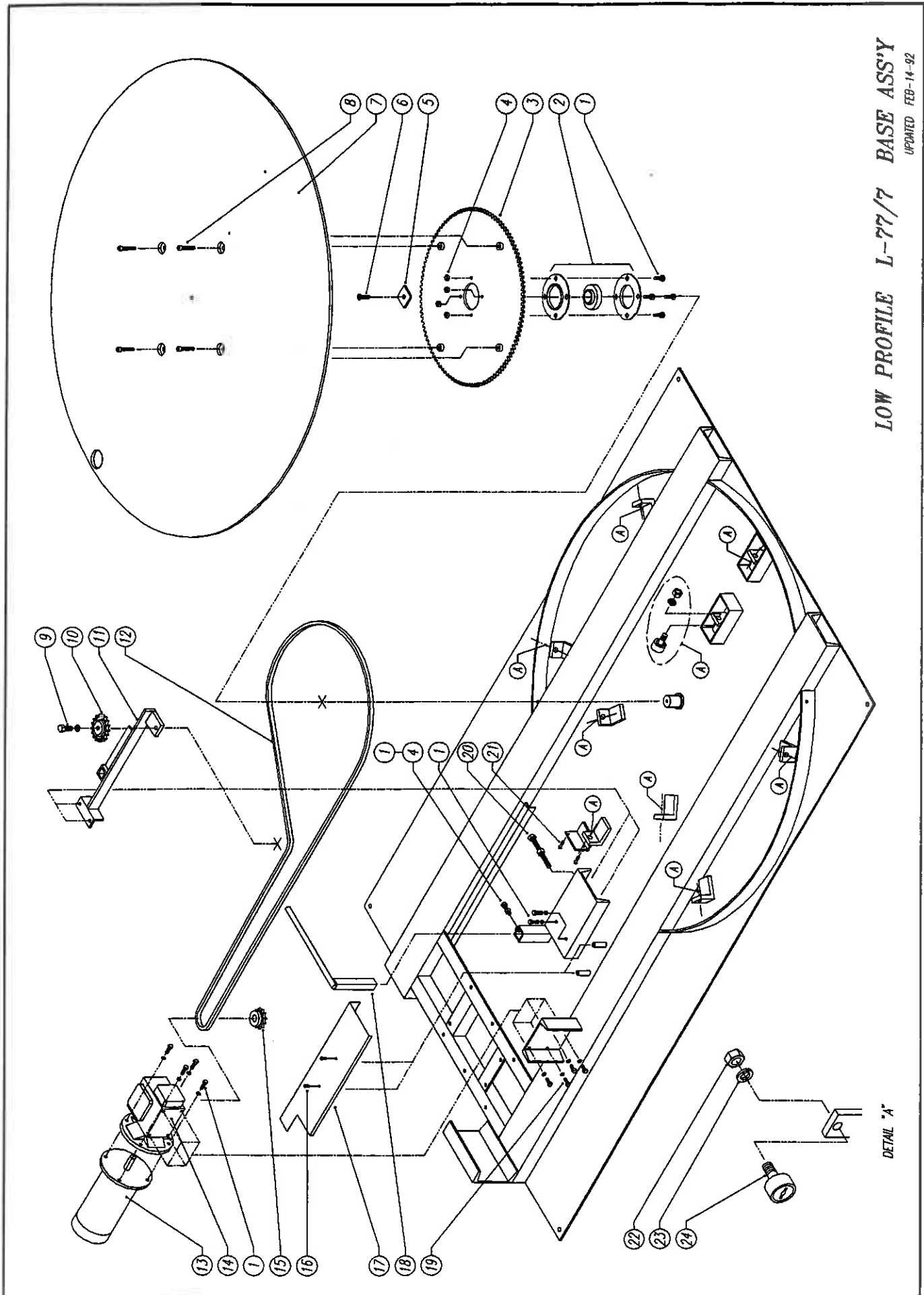

DETAIL "A"

SMALL CARRIAGE ASSY PARTS LIST

<u>PART NUMBER</u>	<u>DESCRIPTION</u>	<u>QUANTITY</u>
10042	3/4" FLANGED BEARING UNIT	2
10049	BRAKE PAD	2/set
10050	FILM SPOOL MANDREL	1
10051	TOP MANDREL	1
10052	1" COLLAR	3
10054	BOTTOM MANDREL	1
10091	CHANNEL GUIDE	1
10092	KNOB	1
10118	PHOTOSWITCH	1
10155	CHANNEL 20" LONG	1
10156	PHOTOSWITCH BRACKET	1
10246	20" CARRIAGE Frame x 13.5" LENGTH	1
10247	20" SNUB ROLLER	1
10248	TOP MOUNTING PLATE FOR BRAKE	1
10249	MULTI STRETCH MECHANISM COVER	1
10250	20" x 3" DIA. RUBBER ROLLER	1
10251	BRAKE ASSY B20	1
10252	SEE P/N 10155	
10291	3/8-16UNC X 1 HEX BOLT	7
10302	8-32UNC x 1/2 BHCS	8
10352	PHOTOSWITCH SCREWS	2
10353	SEE P/N 10291	4
10354	SEE P/N 10291	2
10355	SEE P/N 10291	1
10356	SEE P/N 10302	8
10357	3/4" COLLAR	2

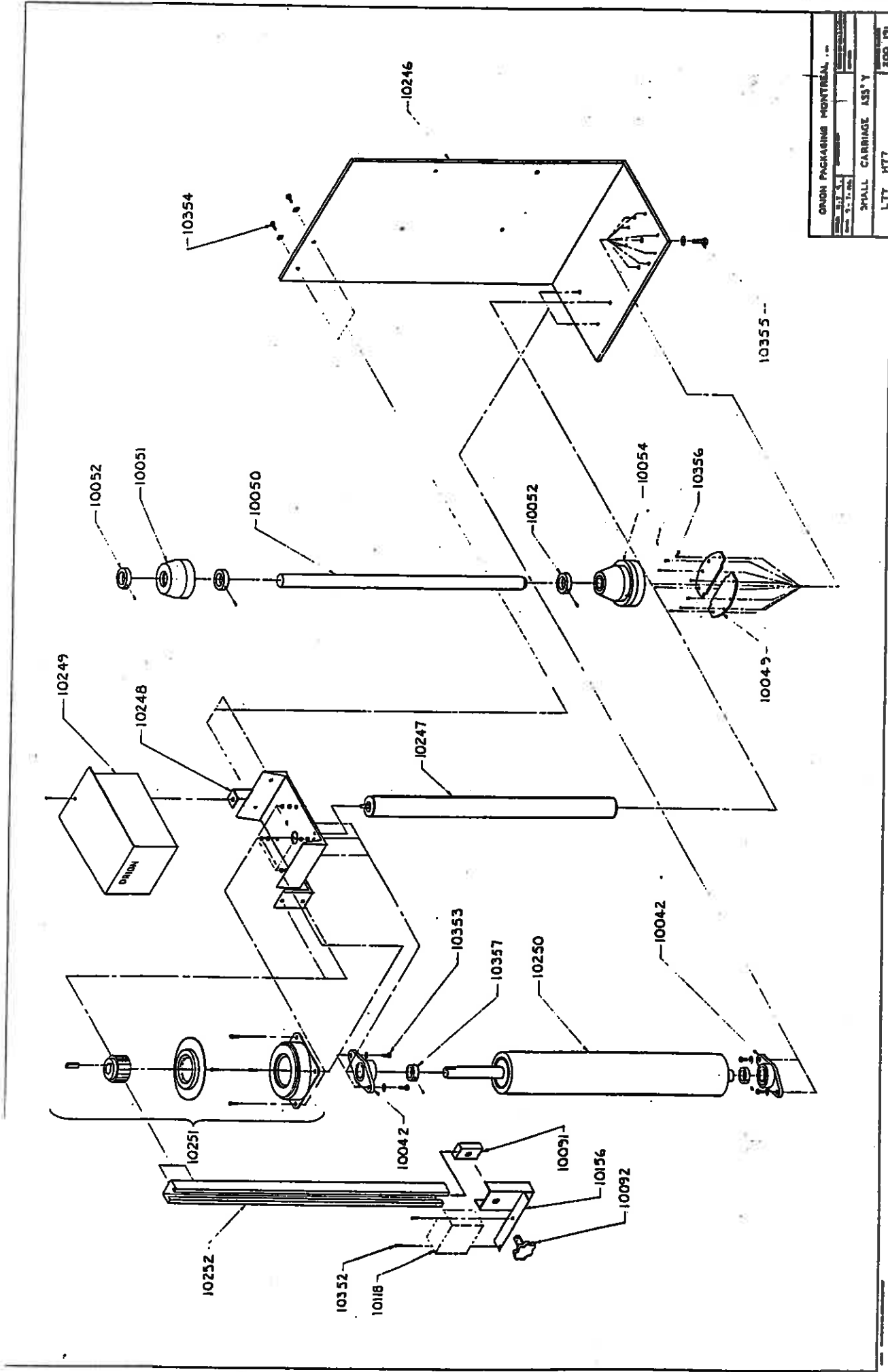

ORION PACKAGING MONTREAL	
REV. 3.1.5	
REV. 3.1.1.006	
SMALL CARRIAGE ASS'Y	
LTT MT77	200 171

ATTENTION:

**WHEN MOUNTING THE CARRIAGE LIFT CHAIN,
PLEASE MAKE SURE, THAT THE CONNECTING
LINK'S PIN IS INSERTED FROM THE TOWER SIDE**

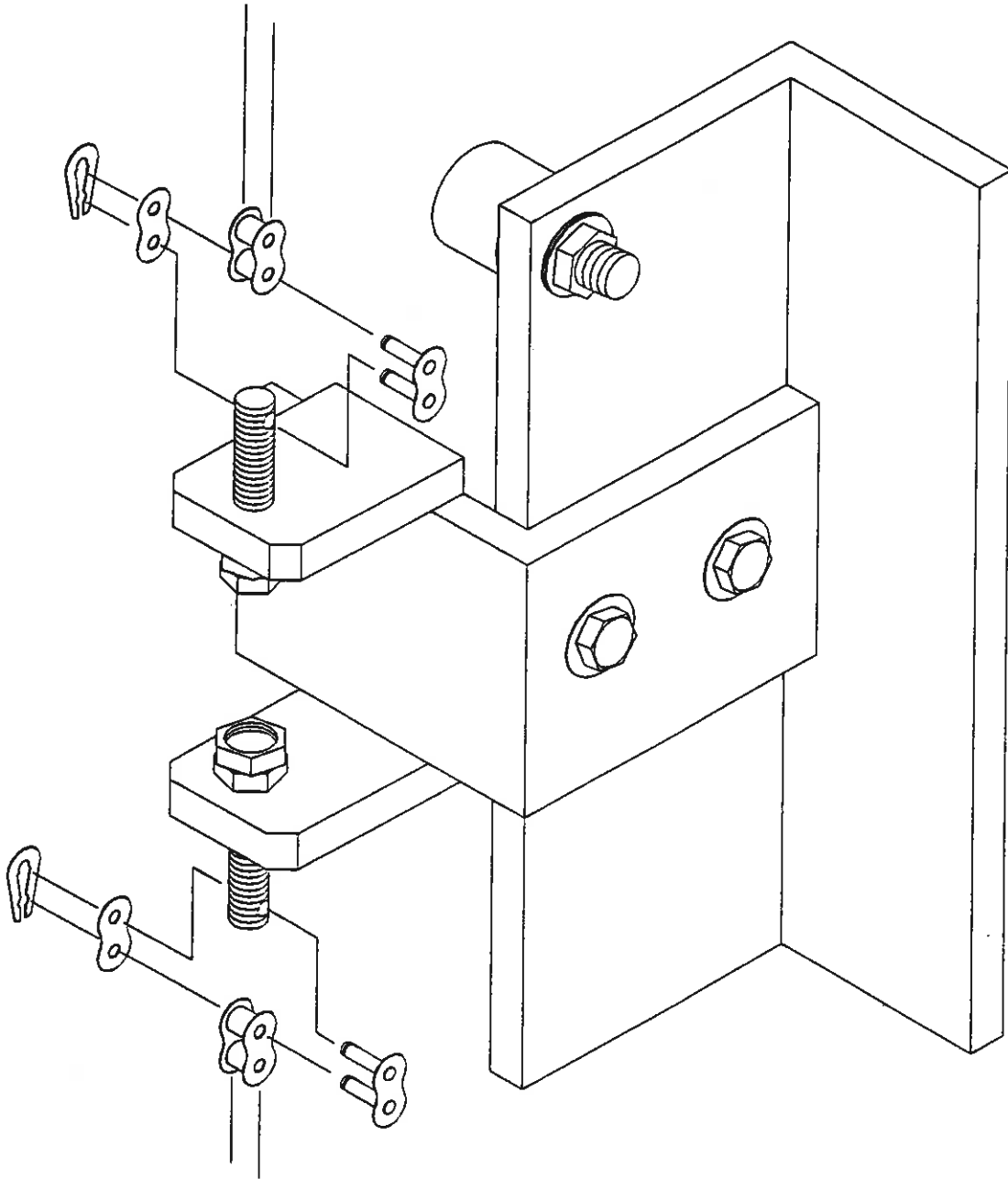

CHAIN TENSIONER ASS'Y

5. MACHINE INSPECTION AND INSTALLATION

5.1 Inspection Upon Arrival

CAUTION: When unloading the stretchwrapper, care must be taken not to lift it by the turntable. The forks of the forklift should be inserted in the 6 inch slots behind the tower to lift the machine.

Before inspection, all packing and restraining blocks must be removed; these may include the blocks under the carriage and the bolts holding the ramp on the table.

CAUTION: When cutting the stretchwrap material covering the machine, care must be taken not to cut any of the electrical lines.

A visual inspection of all the electrical connections should be performed after unpacking the machine to check for loosened joints or broken connections. Any suspected shipping damage must be reported immediately to the freight carrier.

Items that are vulnerable to damage and must be inspected are the motor and transmission housings and connections at the base of the tower, and on the carriage, the photoswitch on the carriage, and the roping bar and stands.

5.2 Machine Installation

After the visual inspection has been performed, the customer is required to provide the electrical power requirements as outlined in the specifications (sections 1, 2, and 3 of this manual).

An electrical diagram is provided in the panel box. Only a qualified electrical technician or an Orion representative should effect any repairs on the machines.



Before operating the machine the oil pockets underneath the table should be checked and filled if any oil is missing (see section 8.4).

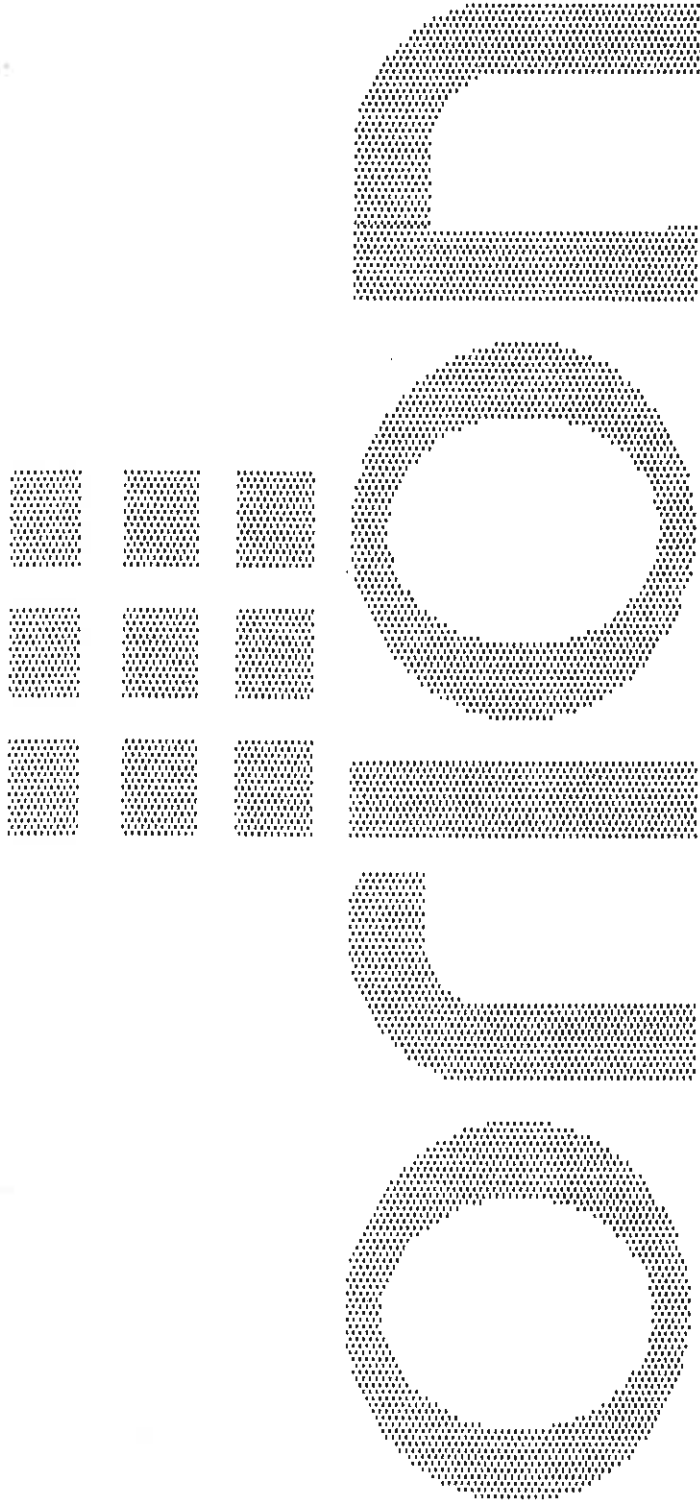

NEW, TWO POSITION CONTROL PANEL MOUNT

In order to facilitate access and manipulation, the Control Panel can be mounted in two positions:

1.- On the angle brackets aligned to the Tower.

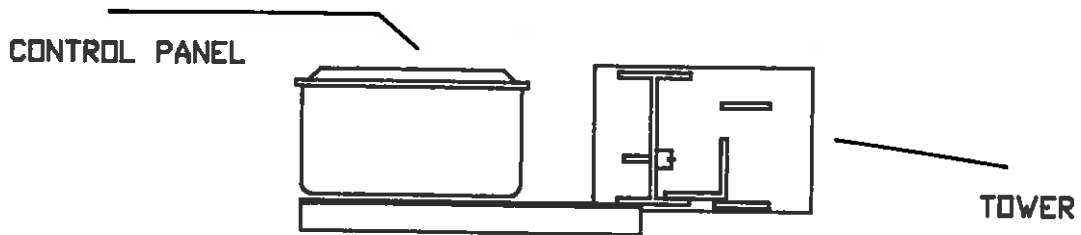

2.- with the position bar (installed between upper angles), Control Panel can be rotated forward/ to the side.

(Additional screw attached to the tower's foot).

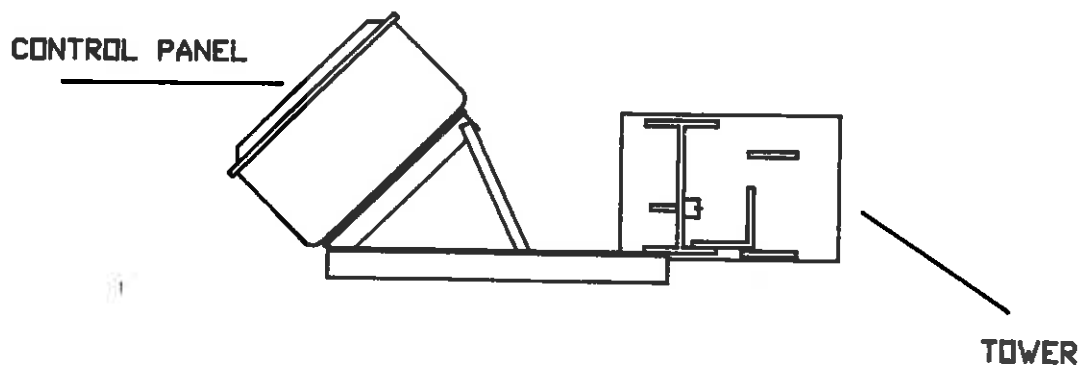

6. MACHINE CONTROLS

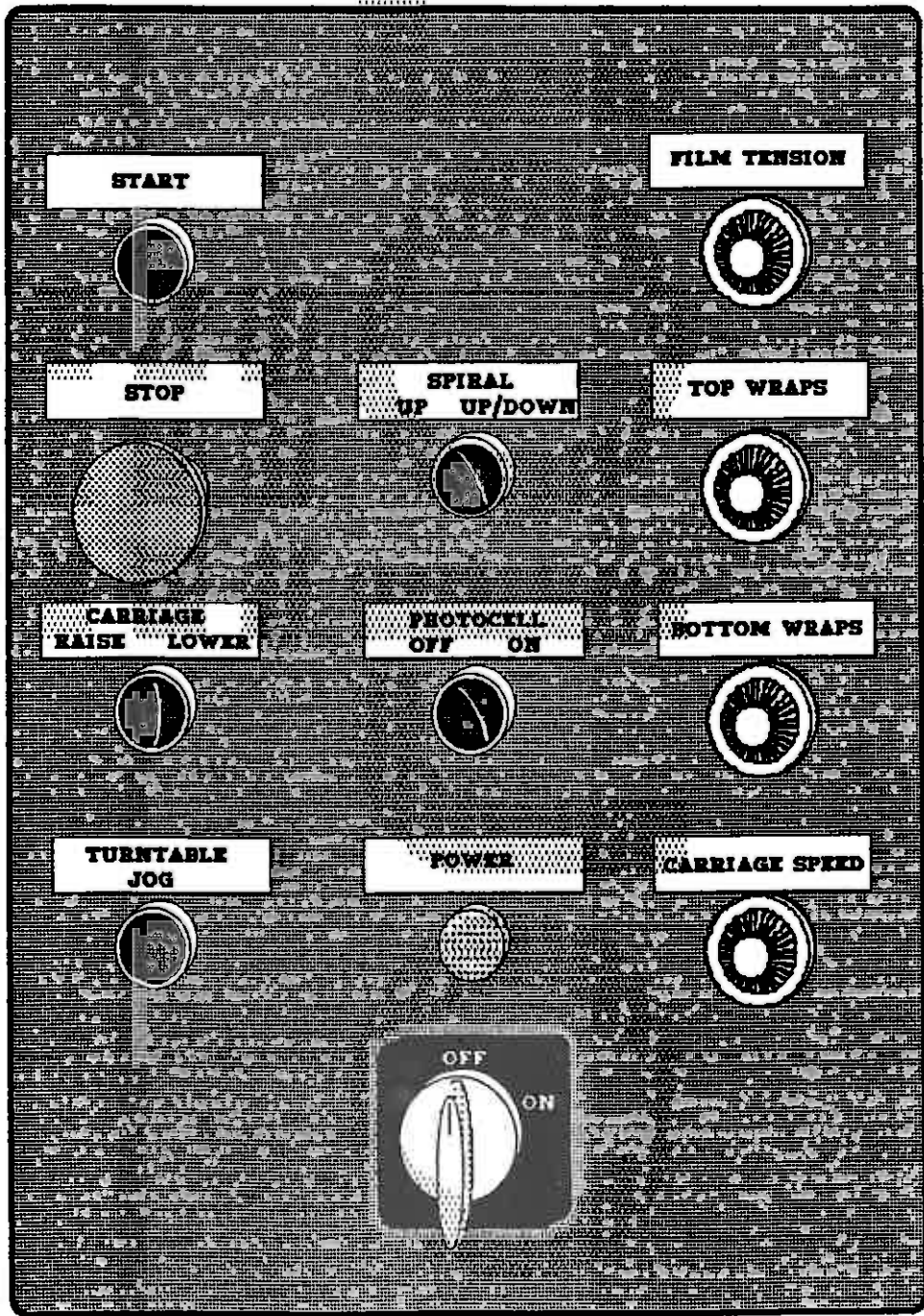

6.1 Power Switch

The Power Switch has two settings,

ON - Connects a 110 VAC power source to the machine,

OFF - Disconnects the power source.

6.2 Start And Stop Switches

The Start switch is used to start the cycle once the load is on the turntable. The cycle may be stopped at any time by pressing the Stop button.

NOTE: if the Stop button is pressed in the middle of the cycle, the carriage and turntable may be returned to their home positions by using the jog buttons before restarting the cycle.

6.3 Spiral Wrap Switch

The Spiral Wrap switch has two positions,

UP - In the UP position the cycle will end after completing the specified number of top wraps, therefore, the machine will only wrap the load once, going up.

UP/DOWN - In the UP/DOWN position the cycle is complete after the load is wrapped in both the up and down directions.

6.4 Turntable Jog Switch

The Turntable jog switch is a pushbutton switch that will turn the turntable in a clockwise direction (as viewed from the top) when the switch is held depressed. When the switch is released the turntable will stop.

The switch is inoperative during the wrap cycle.

6.5 Carriage Control Switch

The Carriage Control switch is a monostable three position switch with the following settings,

RAISE - Raises the carriage until the top limit switch on the tower is activated or until the photo switch senses that the top of the load has been reached.

LOWER - Lowers the carriage until the bottom limit switch on the tower is activated.

The switch is normally in the middle position where the carriage remains stationary. Turning the switch to the RAISE or LOWER position will activate the carriage to move in its respective direction.

6.6 Photocell Switch

The Photocell switch has two settings,

ON - When turned ON, the photocell senses whether or not the carriage has reached the top of the load. The carriage will stop and begin the top wraps sequence once the top of the load is reached. The carriage will always stop at the top of the load regardless of its height. The photoswitch's position on the track can be



adjusted in order to make the carriage pass the top of the load and overlap the top.

OFF - When turned OFF, the photocell is inoperative and the carriage will stop only once the top limit switch has been activated.

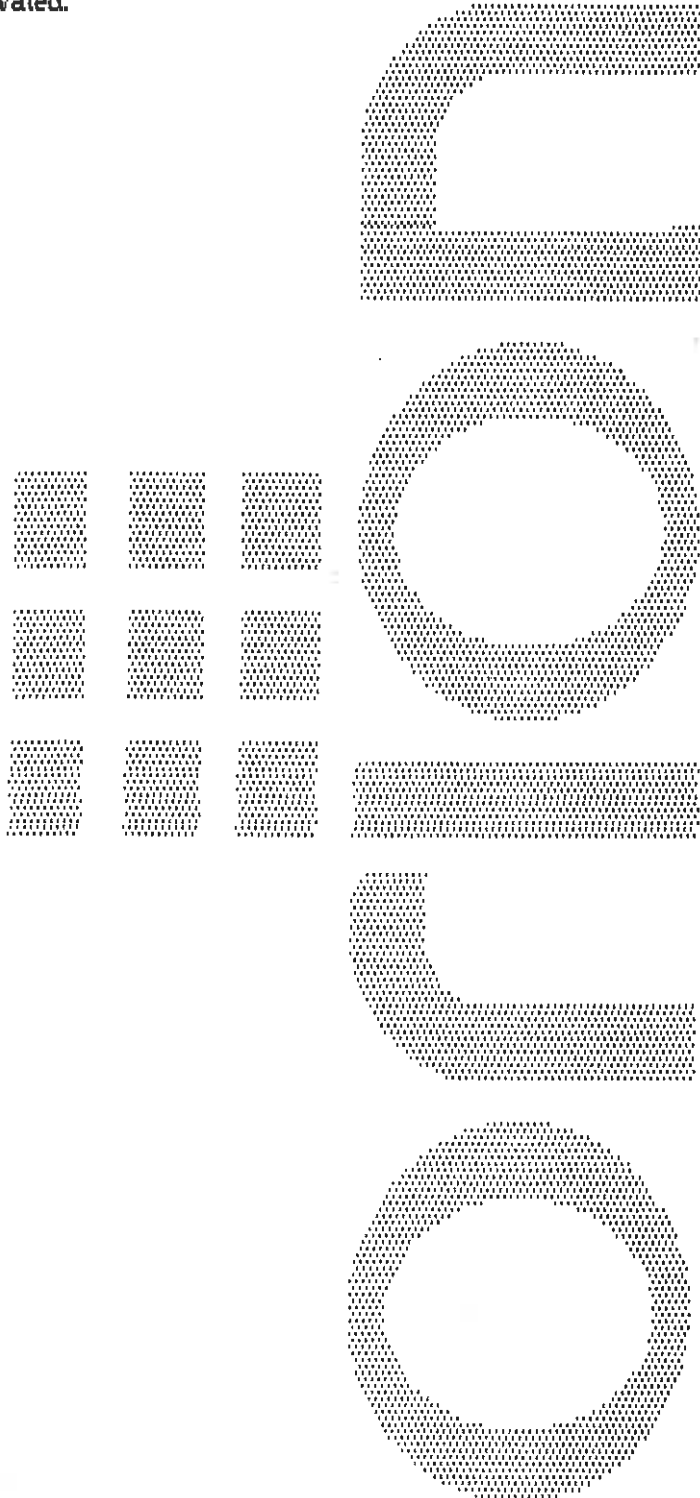

7.1 Film Tension

The film tension may be adjusted through the film tension control potentiometer. The pot has a range of tension from 0 to 10, 10 being the highest tension rating. This pot may be adjusted during the cycle.

CAUTION: Light loads may require lower tension settings than heavier loads.

The film tension is controlled through the dancer bar system. Occasionally the feedback potentiometer may need some adjustment. The adjustment of the feedback potentiometer can be performed while there is no film on the carriage. The bottom screw on the potentiometer coupling must first be loosened. Once the screw is loosened the potentiometer shaft must be turned until the prestretch motor just begins to hum but does not rotate, at which point the screw can be tightened. NOTE: the condition in which the motor hums but doesn't turn must be maintained even after the screw is tightened, if not, the adjustment procedure must be repeated.

7.2 Carriage Speed

The carriage speed control can be used to control the amount of overlap the film will have on itself during a wrap.

The control potentiometer has settings from 0 to 10, the higher settings being the fastest. High settings will mean less film overlap because of faster carriage speed, and low settings will mean more film overlap because of lower carriage speeds.



7.3 Top And Bottom Wraps

There are two multi-position switches which control the number of wraps that may be put at the top and bottom of the load. Each switch has positions going from 1 to 10 corresponding to the number of wraps which may be applied at the top or bottom of the load.

These switches may be set before the cycle begins.

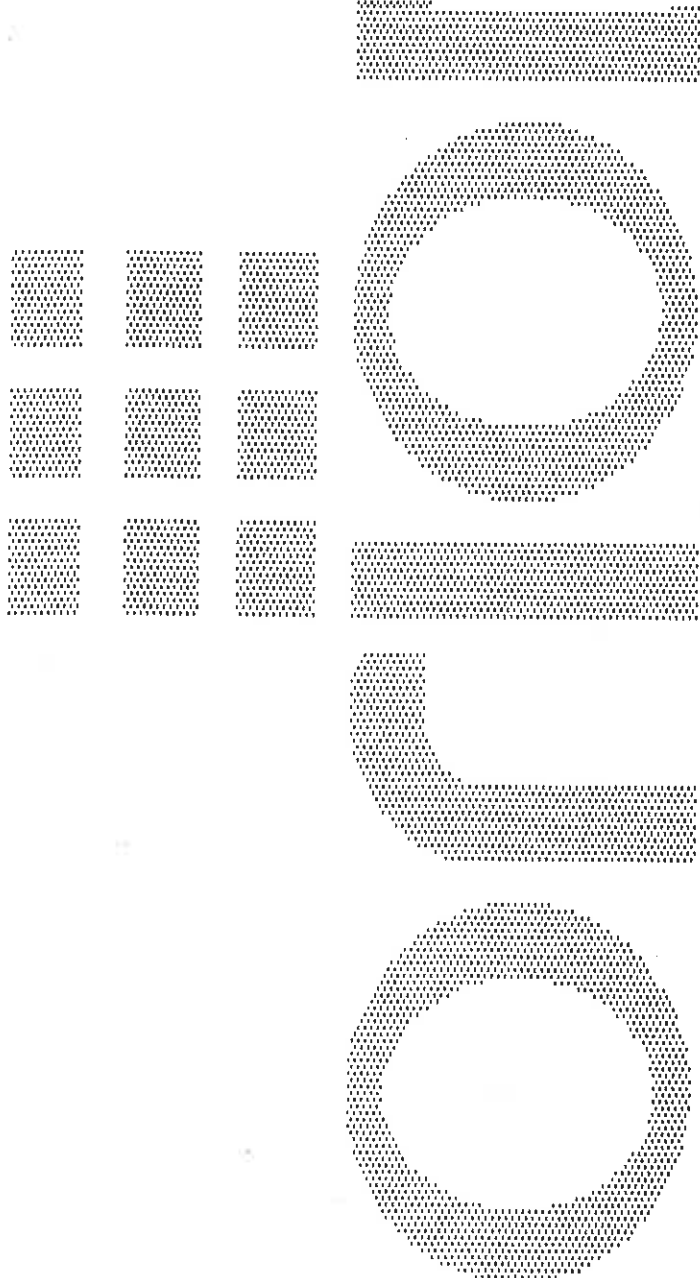

8. MACHINE MAINTENANCE

8.1 Speed Reducer Maintenance

On the reducing transmission, after the first week all external cap screws and plugs should be checked for tightness. It is recommended to change the oil every six months or every 2500 hours of operation, whichever comes first. When adding oil the transmission should never be filled above the oil level mark indicated because leakage and overheating may occur. Below is a list of the type of lubricant that should be used.

Manufacturer	Lubricant
American Oil Co.	American Cyl. Oil No. 196-1
Cities Service Oil Co.	Citgo Cyl. Oil 180-5
Gulf Oil Corp.	Gulf Senate 135
Mobile Oil Corp.	Mobil 600 W Super Cyl. Oil
Phillips Oil Co.	Andes S 180
Texaco Inc.	624-650T Cyl. Oil
Shell Oil Co.	Valvata Oil J82
Union Oil Of Cal.	Red Line Worm Gear Lube 140

Reducing transmissions are found on the carriage, and at the base of the tower.

8.2 Motor Maintenance

An occasional inspection of the brushes should be made in order to establish a wear rate. Replacement brushes should be installed before old brushes wear to 9/16" long, measured on the long side. After



replacing brushes run the motor near rated speed for at least 1/2 hour with no load to seat the new brushes.

Failure to properly seat the new brushes may cause commutator damage and rapid wear of the new brushes. If the commutator becomes rough, scored, or out of round, a competent motor shop should disassemble the motor and resurface the commutator. With every third brush change, have a competent motor shop resurface the commutator and blow the carbon dust out of the motor.

8.3 Chain Maintenance

To clean and relubricate chains, wipe them with an oily cloth every month. If the environment is very dusty or damp, it may be necessary to clean and relubricate the chains more often.

With time the chains will tend to stretch. A loose elevator chain should be tightened at the chain tensioner as shown on drawing number 200-192. A loose turntable drive chain should be tightened by tightening the 1/2" dia. screw on the base, next to the turntable.

8.4 Cam Follower Maintenance

The cam followers behind the carriage have deep grease pockets and do not need frequent relubrication.

The portion of the tower on which the cam followers roll should be cleaned and regreased every 300 hours of operation. If the machine operates in a dusty or corrosive environment the tower should be relubricated more often.

The cam followers under the turntable are wet with oil in order to keep the track properly lubricated. The oil pockets should be refilled every 200 hours of operation. The two oil pockets are found on the base, underneath the table.

APPENDIX
C
O

ORION PACKAGING INC.

NOTICE

The manual covers standard features of the machine. Certain machine options may not be covered fully by this manual due to their unique application.

	168-4	168-A	336-6	750 MX	850 M	850 C	155-3	850 D
L-77, H-77		X					X	X
M-77		X				X	X	
M-67		X	X				X	X
M-67 PA		X	X		X		X	
M-67 DEMO		X	X		X		X	
M-66, L-66, H-66		X	X		X		X	
M-57		X	X				X	X
M-55, L-55, H-55		X	X		X		X	
M-44, L-44, H-44	X		X	X			X	
*M-44, *L-44, *H-44	X		X	X				

* - PROCESSOR

PA - POSITIVE ALIGNMENT

DEMO - DEMO PACKAGE

336-6 - REPLACES 336-4

ELECTRICAL BOARDS' CHART
FOR ORION STRETCHWRAPPERS

MOTOR CONTROL BOARD CALIBRATION INSTRUCTIONS
FOR 750-MX BOARD

The 750-MX Motor Control Board is a multi-purpose DC/SCR drive that is used in several different types of applications in Orion wrapping equipment. The following calibration instructions apply to all possible types of machinery, but it will be important to note specific reference to your particular model Orion machine for best calibration results. The instructions are in the suggested order of adjustment and are intended to be made after installation of the board in the control enclosure. Please refer to the attached sketch of the board for identification of the adjustment points.

Important Note: The 750-MX Motor Control Board is a dual voltage capability board. It is imperative that you set the board for the voltage of your application prior to installation, calibration, or use of board. Set the 90V/180V jumper pin to the proper position for the motor that your Orion machine turntable or tower drive utilizes. Next, you must also set the 115V/230V jumper pins to the proper position. (If your turntable or tower drive motor is 90V, the proper position for the 115V/230V pins is on the 115V posts. Conversely, if your turntable or tower drive motor is 180V, the proper position for the 115V/230V pins is on the 230V posts.)

Zero Setting: (Pot #4) The zero potentiometer establishes the "zero" point for many of the other settings on the board, and as such, it is important that it be set first. First, turn Preset 2 (Jog Speed, Pot #2) fully counterclockwise (CCW) until you hear the faint clicking indicating full CCW. Then turn the Preset 2 Pot 1 turn clockwise (CW). Then, with power applied and the machine in "Manual" (if applicable), activate the turntable or tower jog pushbutton or selector switch. While activating the jog switch, turn the "Zero" pot CW until the tower or turntable just moves, and then turn Zero CW until movement stops. Note: On fully automatic models, it will be necessary to remove power from the machine, and push the turntable or tower away from home position slightly, to allow activation of the jog speed.

Accel: (Pot #5) This pot controls the soft start feature of the turntable or tower drive. For an initial setting, turn the accel pot fully CCW, and then 1/4 turn CW. For a softer start of the turntable or tower, turn the accel pot further CW. For a quicker start of the turntable or tower, turn the accel pot CCW.

Preset 1: (Pot #2) This pot controls the turntable or tower low speed. For best calibration results, it is recommended that you cause the machine to remain in the low speed mode while you make this adjustment. On semi-automatic models with a control panel selector switch for High/Low speed, simply place the switch in the low speed position, and start the machine, adjusting the speed while the machine is running. On fully automatic models, set the film carriage "up" speed control to the "0" (minimum) position, and start a wrap cycle. This will prevent the film carriage from reaching the top of the load, at which time the PLC would normally switch to high speed. Then, adjust the Preset 1 pot to achieve the low speed that you desire for the turntable or tower, turning CW to increase speed, or CCW to decrease speed. The normal setting for low speed is 10 RPM.

Preset 2: (Pot #1) This pot controls the turntable or tower jog speed. Simply activate the turntable or tower jog control, adjusting the jog speed as the tower or turntable rotates. The desired jog speed is 2-3 RPM. CW increases jog speed, while CCW decreases jog speed. (See note in "Zero Setting" paragraph above)

Preset 3: (Pot #3) This pot controls the turntable or tower high speed. For best calibration results, it is recommended that you cause the machine to remain in the high speed mode while you make this adjustment. On semi-automatic models with a control panel selector switch for High/Low speed, simply place the switch in the high speed position, and start the machine, adjusting the speed while the machine is running. On fully automatic models, start a wrap cycle and set the film carriage speed control to the "0" (minimum) position. This will prevent the film carriage from reaching the bottom of the load, at which time the PLC would normally switch to jog speed. Then, adjust the Preset 3 pot to achieve the high speed that you desire for the turntable or tower, turning CW to increase speed, or CCW to decrease speed.

Deceleration #1,2: (Pot #6) The deceleration 1,2 pot controls the transition time that the board provides when it is switched to jog speed at the end of the cycle. Start with the decel 1,2 pot set fully CCW. Then, cycling the machine, observe the transition to jog speed at the end of the cycle, prior to the stop of turntable or tower at home position. Gradually increase the Dec 1,2 pot setting (CW) until the turntable or tower only jogs approximately 1/8 to 1/4 turn before reaching home position.

Important Note: On high speed Orion models (30 RPM turntable or tower drives, with turntable or tower brake) the deceleration control is not used, and must be set to minimum, or fully CCW.

Deceleration #3: (Pot #7) The deceleration 3 pot controls the transition time when the board is switched from high speed to jog speed at the end of the cycle, on relay logic semi-automatic models only. With the control panel turntable/tower speed high/low speed selector switch in the "high" speed position, cycle the machine, and adjust the Dec 3 pot as above, starting from minimum (fully CCW).

Important Note: On high speed Orion models (30 RPM turntable or tower drives, with turntable or tower brake) the deceleration control is not used, and must be set to minimum, or fully CCW.

Current Limit: (Pot #9) The current limit pot controls the torque (Amps) that the board allows to the motor. This control should be set using an amprobe to limit the amps flowing to the motor nameplate rating, under full load. However, the setting may be temporarily set approximately, using a 2 HP maximum as a guideline.

Example - If the turntable or tower drive of your Orion machine is 1 HP, set the current limit pot to a 1/2 CW position.

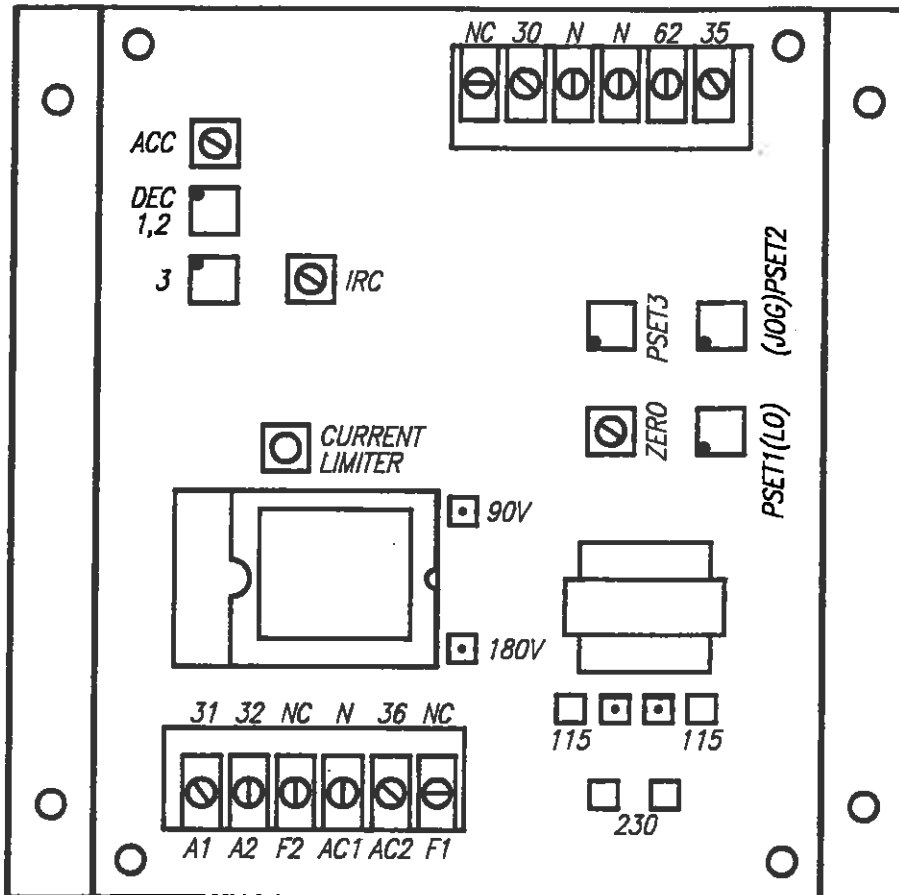

ZERO: TURNTABLE DEADBAND ADJUSTMENT.
 PSET1: LOW SPEED ADJUSTMENT.
 PSET2: JOG SPEED ADJUSTMENT.
 PSET3: HIGH SPEED ADJUSTMENT.
 IRC: LOAD RANGE ADJUSTMENT.
 ACC: ACCELERATION ADJUSTMENT.
 DEC1,2: LOW SPEED DECELERATION ADJUSTMENT.
 DEC3: HIGH SPEED DECELERATION ADJUSTMENT.
 CURRENT LIMITER: CURRENT LIMITER ADJUSTMENT.

35: SPEED CONTROL (JOG)	F1(NC): FIELD CONTROL
62: SPEED CONTROL (FAST)	AC2(36): AC INPUT.
N: NEUTRAL	AC1(N): NEUTRAL.
30: SPEED CONTROL (MEDIUM)	F2(NC): FIELD CONTROL.
NC: NOT CONNECTED	A2(32): ARMATURE CONTROL.
	A1(31): ARMATURE CONTROL.

750 MX REV-1 BOARD

TURNTABLE MOTOR CONTROL 850 M BOARD ADJUSTMENT
66 AND 55 SERIES EQUIPMENT

Older revision 850 M boards feature five potentiometers, while newer revision boards feature four. In any case, they will be marked A, D, 1 and 2 (with an additional pot marked T on older boards).

The pot marked A is the acceleration or electronic soft start feature. Clockwise adjustment of this potentiometer softens the start and lengthens the time required for the turntable to reach its preset turntable speed.

The pot marked 1 is the turntable jog speed, and should be set for approximately 2 RPM. Please note that this setting should be made with a load on turntable.

The pot marked 2 is the control pot for the running speed of the turntable during the wrap cycle once acceleration is complete. This speed can be as high as 12 RPM; however, you should note that if it is set too high, you may see chopping of the current to the turntable drive motor which will cause pulsating half speed operation of the turntable drive itself. If this is seen, please decrease the setting of pot 2, until it goes away.

The pot marked D is the deceleration control. It is a critical setting because our machine logic requires that we decelerate from speed 2 to speed 1 during the course of the final revolution of the turntable before shutoff. Thus, the deceleration control is important in that if deceleration time is too short, we will prematurely reach jog speed (speed 1) and jog an excessive amount of time to the home position before shutoff.

Conversely, if the deceleration time is set too long, the turntable will not settle to the jog speed and thus will be going too fast to align properly and momentum will take turntable beyond home position.

Any time the wrap speed is changed, you will need to make a corresponding change in the setting of the pot marked D for deceleration. Pot D is adjusted clockwise to shorten deceleration time.

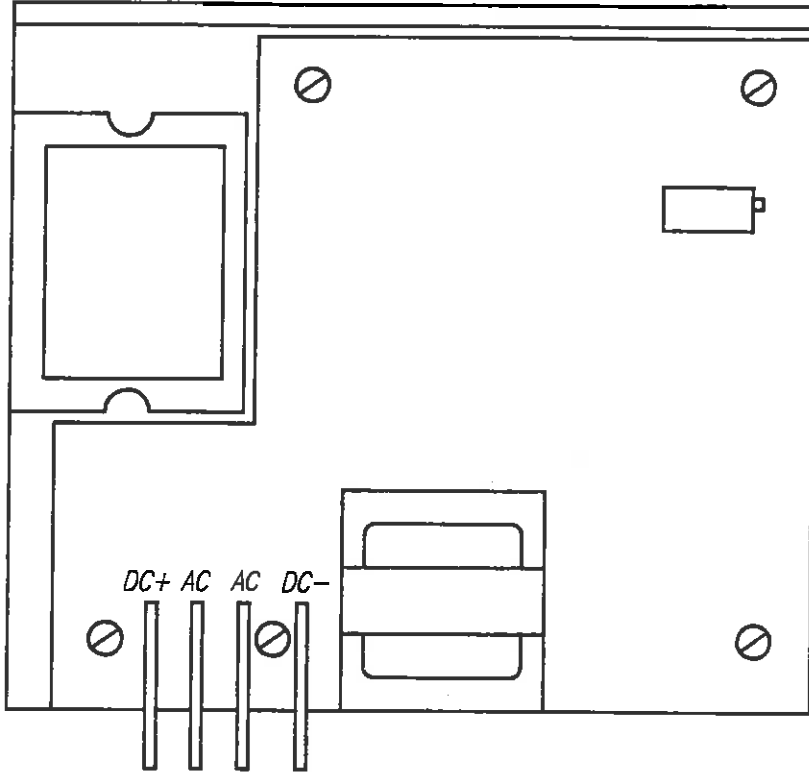

DC+: ARMATURE CONTROL
 AC: AC INPUT
 AC: AC INPUT
 DC-: ARMATURE CONTROL

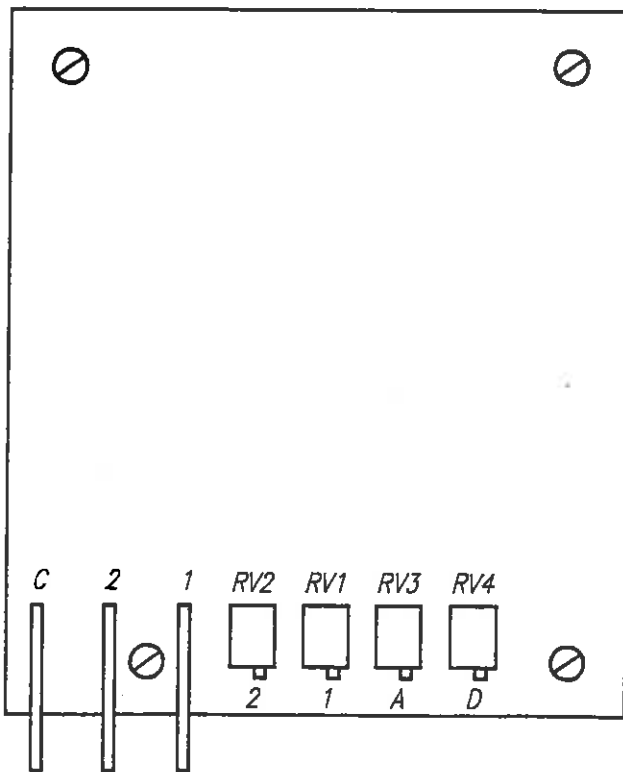

C: COMMON
 2: SPEED CONTROL (HIGH)
 1: SPEED CONTROL (SLOW)

POTENTIOMETERS:

2: HIGH SPEED ADJUSTMENT
 1: LOW SPEED ADJUSTMENT
 A: ACCELERATION ADJUSTMENT
 D: DECELERATION ADJUSTMENT

850M 2 SPEED DC
 MOTOR CONTROL BOARD

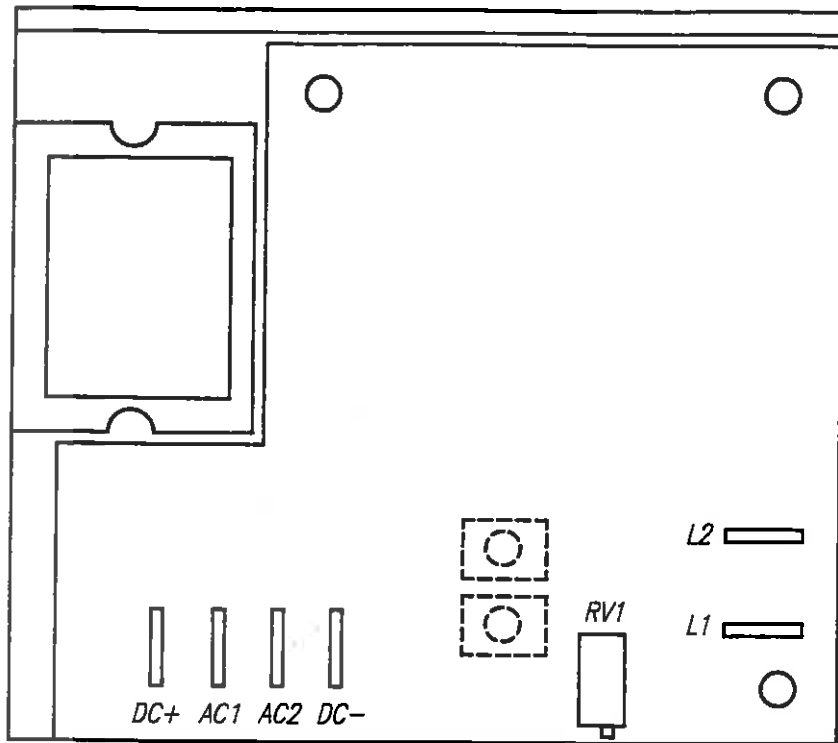

DC+: ARMATURE CONTROL.
 AC1: AC INPUT.
 AC2: AC INPUT.
 DC-: ARMATURE CONTROL.

RV1: MOTOR SPEED ADJUSTMENT.
 L1: AC CONTROL.
 L2: AC CONTROL.

850C SINGLE SPEED DC
 MOTOR CONTROL BOARD

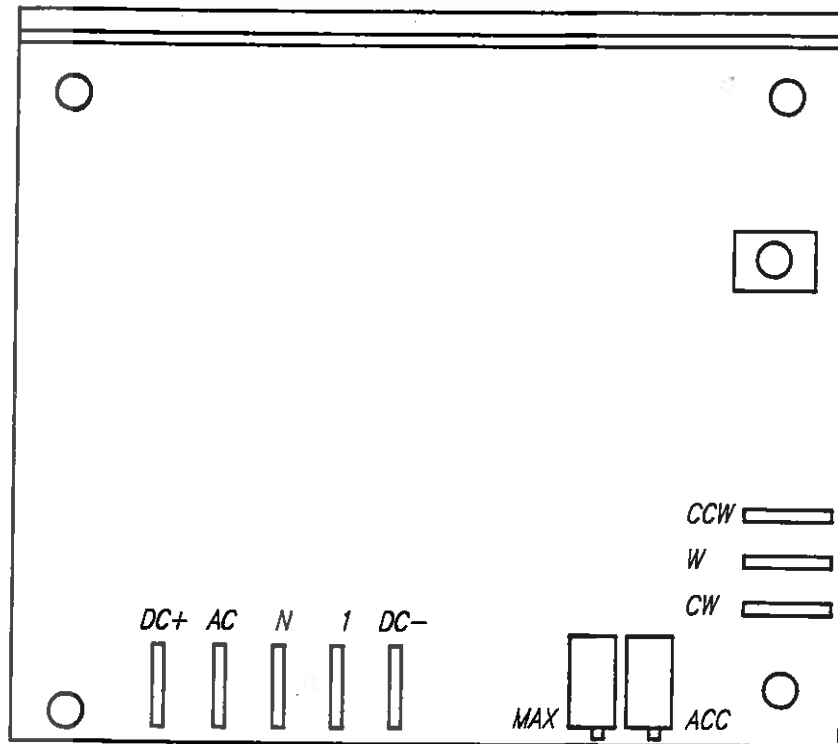

DC+: ARMATURE CONTROL.
 AC: AC INPUT.
 N: NEUTRAL.
 1: CONTROL.
 DC-: ARMATURE CONTROL.

POTENTIOMETERS:

MAX: MOTOR SPEED ADJUSTMENT.
 ACC: ACCELERATION ADJUSTMENT.

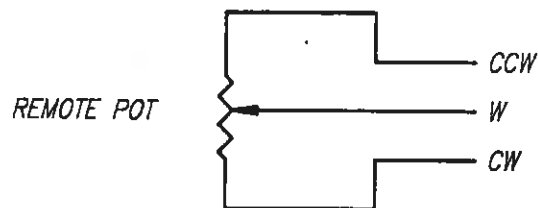

850D SINGLE SPEED DC
 MOTOR CONTROL BOARD

TURNTABLE 850D MOTOR CONTROL (for H&L77)

Acceleration: (ACC Pot) The ACC pot controls the soft start feature of the 850D Board.

For an initial setting, turn the ACC pot fully counter clock wise (untill a clicking sound is heard), and then approximately 11 turns or revolutions clock wise. For a smoother start of the turntable, turn the ACC pot further CW. For a quicker start, turn the ACC pot CCW.

Speed Control: (MAX Pot) The MAX pot controls the turntable running speed during the wrap cycles. This speed is set at 10 r.p.m.

For an initial setting, the remote pot located on the front panel should be set to maximum, (i.e. fully CW). Using the pot on the board marked MAX set the turntable speed to achieve 10 r.p.m. A CW turn will increase the speed, CCW will decrease the speed.

In order to compensate for unstable and various load sizes, the 850D board features a remote Turntable Speed adjustment which is located on the front panel. This pot is provided to reduce the wrapping speed during a wrap function.

Since the 850D is a single speed board, the jog function will jog the turntable at 10 r.p.m.

NOTE: It is recommended that Turtable Speed be reduced when jogging unstable loads.

MULTISTRETCH 850D MOTOR CONTROL (for H&L77)

Acceleration: (ACC Pot) The ACC pot controls the soft start feature of the 850D Board.

For an initial setting, turn the ACC pot fully counter clock wise (untill a clicking sound is heard), and then approximately 8 turns or revolutions clock wise. For a softer start on the Multistretch motor, turn the ACC pot further CW. For a sharper response, turn the ACC pot CCW.

Note: If acceleration time is too low, an excessive amount of film will be ejected prior to the turntable achieving maximum speed.

Speed Control: (MAX Pot) The MAX pot controls the running speed of the Multistretch motor during the wrap cycles or any time dancer bars are deliberately moves.

For an initial setting, (w/turntable not running) the Film Tension remote pot located on the front panel should be set to minimum (i.e. fully CCW). Using the pot on the board marked MAX, set the Multistretch speed to achieve stable condition, (i.e. a smooth continious release of film). A CW turn will increase the speed, CCW will decrease the speed.

This board also features a Film Tension adjustment which is located on the front panel.

Note: If speed is too high dancer bars will jolt back and forth which in turn will switch the motor off and on. This will cause the film to be released unevenly.

CONVEYOR 850D MOTOR CONTROL

Acceleration: (ACC Pot) The ACC pot controls the soft start feature of the 850D Board.

For an initial setting, turn the ACC pot fully counter clock wise (untill a clicking sound is heard), and then approximately 12 to 15 turns or revolutions clock wise. For a smoother start of the conveyor, turn the ACC pot further CW. For a quicker start, turn the ACC pot CCW.

Speed Control: (MAX Pot) The MAX pot controls the conveyor running speed.

The conveyor running speed should be set with the aid of tachometer. A clock wise turn will increase the speed, a counter clock wise turn will decrease the speed.

NOTE: Inputs W and CW are shorted in conveyor motor control.

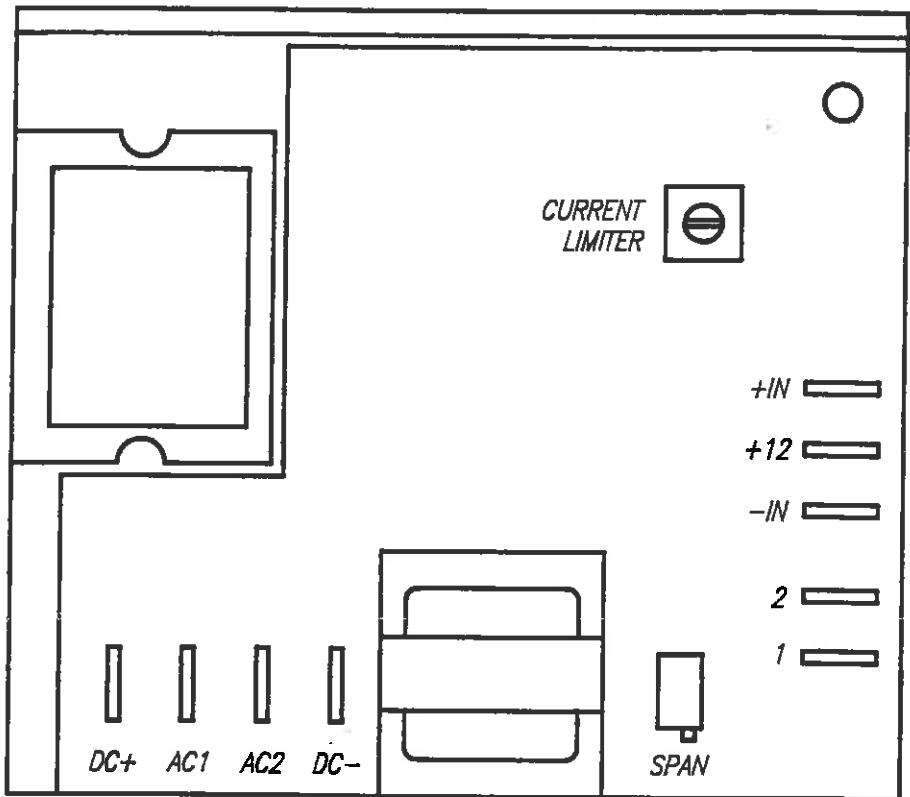

DC+: ARMATURE CONTROL

AC1: AC INPUT

AC2: AC INPUT

DC-: ARMATURE CONTROL

POTENTIOMER

SPAN: HALL EFFECT SENSITIVITY CONTROL

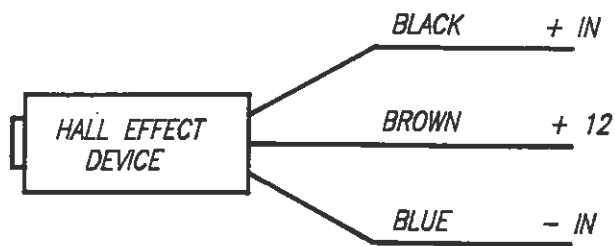

*FILM TENSION ADJUSTMENT
REMOTE POTENTIOMETER*

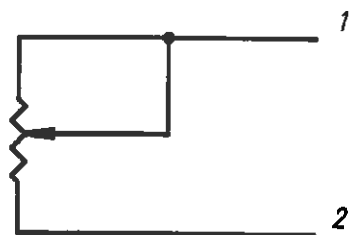

336-6
MULTISTRETCH BOARD

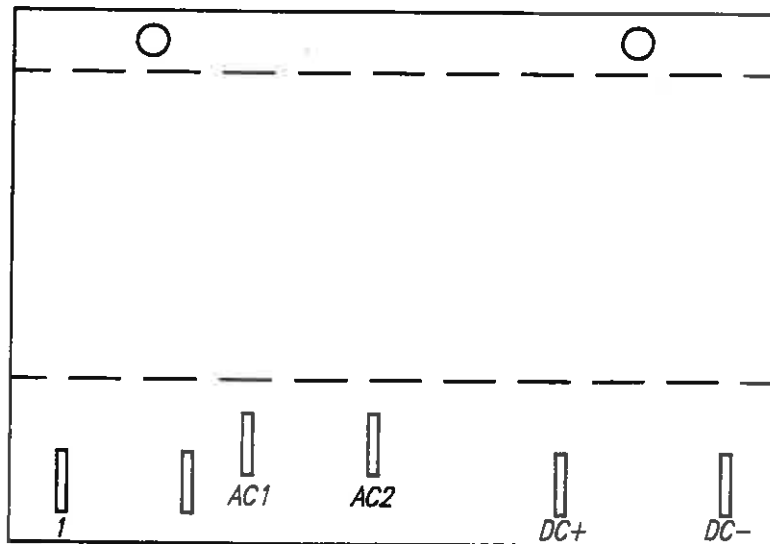
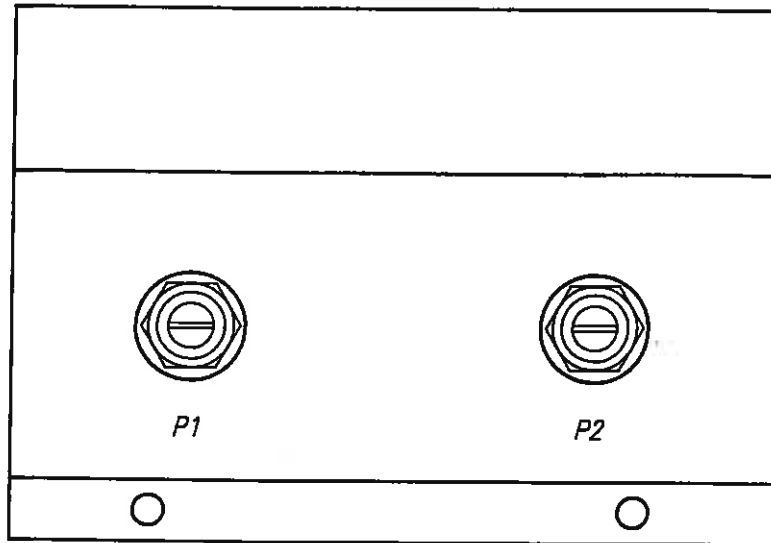

1 : PLC CONTROL
 AC1: AC INPUT
 AC2: AC INPUT
 DC+: ARMATURE CONTROL
 DC-: ARMATURE CONTROL

 POTS: SPEED ADJUSTEMENT.

168-4 CARRIAGE
 DOUBLE SPEED BOARD

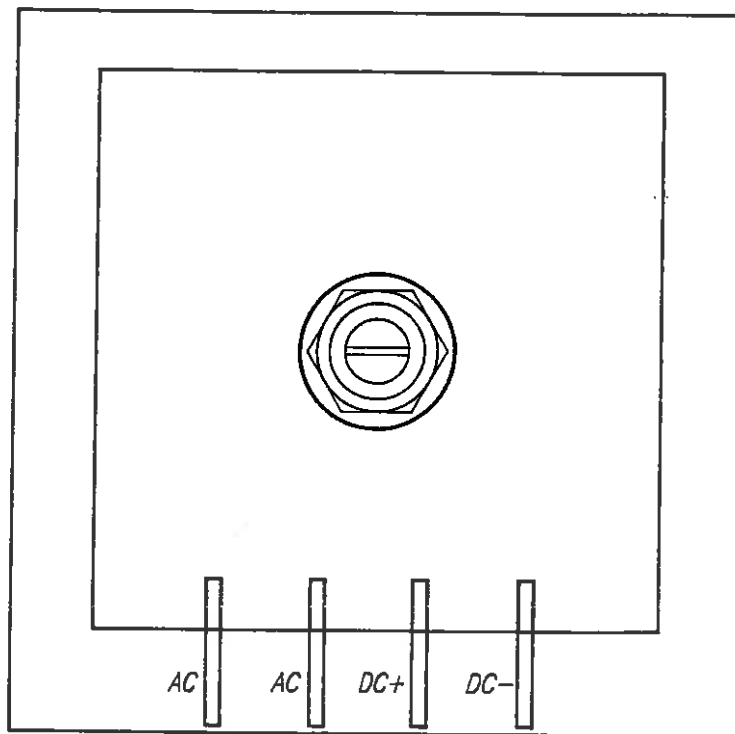

AC: AC INPUT
AC: AC INPUT
DC+: ARMATURE CONTROL
DC-: ARMATURE CONTROL

168-A
CARRIAGE SINGLE SPEED BOARD

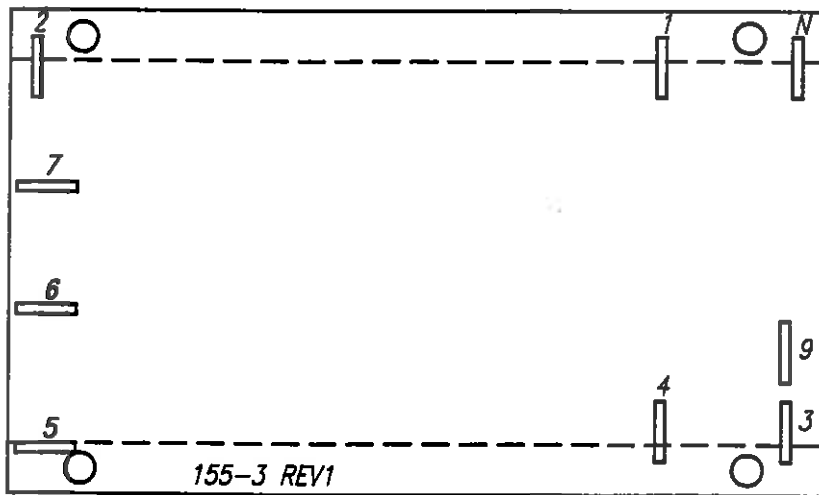
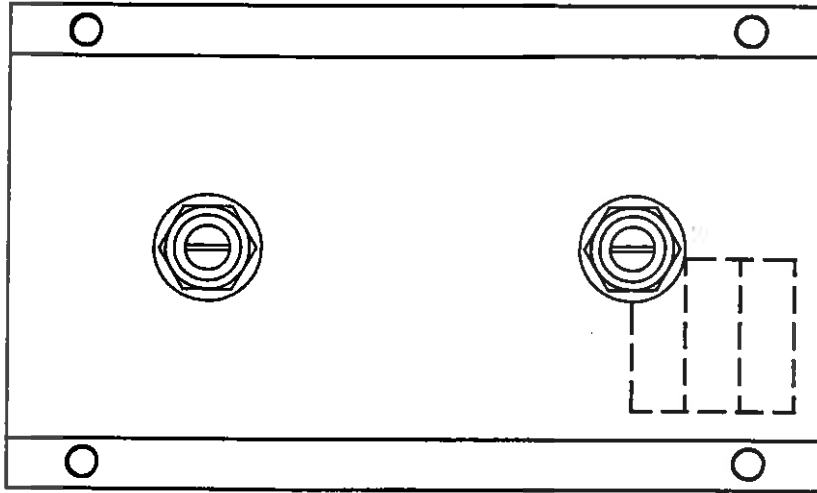

- | | |
|---------------|---------------|
| 1: AC INPUT | 7: OUTPUT B/W |
| 2: AC INPUT | 8: N/A |
| 3: COUNT | 9: COMMON |
| 4: RESET | N: NEUTRAL |
| 5: OUTPUT | |
| 6: OUTPUT T/W | |

155-3
COUNTER BOARD



MAINTENANCE INSTRUCTIONS

STANDARD REDUCERS SERIES 133, 175, 206, 262, 325

INDEX

	Page
Introduction	1
Equipment Required	1
General Instructions	1
Housings	1
Seals	1
To Change Output Shaft Direction	1
Disassembly, Parts Service, and Reassembly	1
Disassembly	1
Low Speed Shaft Removal	1
High Speed Shaft Removal	1, 2
Parts Service	2
Housing	2
Seal Cages and End Cover	2
Air Vent	2
Seals	2, 3
Bearings	3
Worm Gear and Shaft	3
Unit Reassembly	4
High Speed Shaft Assembly	4
Low Speed Shaft Assembly	4
Preventive Maintenance	6
Stored and Inactive Units	6
Parts Ordering Instructions	6
Exploded Views	7, 8, 9
Parts List	9
Warranty	Back Cover

CAUTIONS (Continued)

- DON'T** immerse your unit in liquids or vapors unless it was specified for that job.
- DON'T** seal head with silicone materials.
- DON'T** exceed the ratings indicated on THERMOSWITCH unit shell.
- DON'T** thermally shield unit from medium being controlled.
- DON'T** remove adjusting screw or turn adjusting screw in farther than necessary for desired operation. This action may permanently damage the unit and may void standard Fenwal warranty!
- DON'T** oil your unit. Oil around adjusting screw will flow inside, contaminating contacts.
- DON'T** allow moisture buildup in head cavity area of 37X0X0-000 Moisture Resistant Units. Where excessive moisture is a problem, specify Special Feature 01-982039-00X when ordering.
- DON'T** try to repair unit yourself.
- DON'T** handle unit with pliers or force it into position either by hand or tools, or apply excessive torque in tightening threaded units.
- DON'T** subject shell of unit to deformation.
- DON'T** over-torque threaded units.

TESTING AND ADJUSTMENT



The arrow on the head of THERMOSWITCH unit indicates direction to turn adjusting screw to increase temperature setting. Torque in excess of 15 inch pounds on adjusting sleeve will deform slot.

Each full turn of adjusting sleeve will change temperature the approximate number of degrees as follows:

TABLE II - Adjustment Rates for Thermostat Units

TENSION OPERATED		COMPRESSION OPERATED	
Catalog Series Number	Approx. F° per full turn of adj. sleeve	Catalog Series Number	Approx. F° per full turn of adj. sleeve
15050 to 16051	165	13121-1	1000
17000 to 17503	90-115	17020 to 17523	90-100
17700 to 17701	145	17720 to 17721	85
17702 to 17703	180	17722 to 17723	100-150
17800 to 17801	125	17820 to 17821	75
17802 to 17803	160	17822 to 17823	115
18000 to 18003	80-100	18020 to 18023	70-135
01-37X0X0-000	90		

After the THERMOSWITCH unit has been installed, final adjustment can be made by allowing the unit to operate for several cycles to permit the controlled system to stabilize and then adjust to desired temperatures. The system should then be cooled to ambient temperature, reheated and stabilized to check the setting.

To adjust a high temperature moisture resistant THERMOSWITCH unit (Cat. No. 01-370020-000) it is necessary to remove the seal cap. A screwdriver adjustment is then made internally. Use caution when making adjustments at temperature extremes.

Where extremely accurate temperature control is desired several adjustments may be necessary to stabilize the THERMOSWITCH control after which the adjustment will be maintained.

CONTACT PROTECTION

Capacitors are not required under average conditions. For smoother control at small loads, on D.C. applications or to prevent contact bounce due to vibration, the following table is recommended as a guide:

TABLE III - Contact Protection

VOLTAGE	SERVICE	CAPACITANCE MFD (non-polarized)
120VAC	Resistance	Non required
240VAC	Resistance	.1
120 or 240VAC or DC	Relays, Magnetic Contactors	.001 to .01
15-25VAC or DC	Relays	.02
120 or 240VAC	Motor	Use Relay

NOTE: Capacitors should be wired in parallel with thermostat lead connections. Capacitors should be rated for a minimum of 600VDC with 120VAC circuits and a minimum of 1000VDC for 240VAC circuits.

TESTING TEMPERATURE SET POINT

The *Set Point Temperature* is the temperature at which the contacts on a THERMOSWITCH unit just "make" (close). All THERMOSWITCH units are set at room temperature (75°F ± 15°F) unless otherwise specified in which case they are factory preset at any specified temperature within listed temperature range and setting tolerance of THERMOSWITCH unit.

If customer requires testing of temperature set point, it is recommended that testing devices can be used similar to those at the factory. An ideal thermal installation may require that the THERMOSWITCH unit be located as near as possible to the heat source. Testing the temperature set point of a THERMOSWITCH unit in an application or under conditions where heat source is remotely located from THERMOSWITCH unit, or when ambient temperature conditions are far below or above 75°F, may give misleading results. In some cases, this has led to rejection of units which were actually within proper setting tolerance. Therefore we recommend the use of a Fenwal Model 80001-0 Test Kit, for testing temperature set points on Fenwal THERMOSWITCH units.

For customers who wish to build their own test equipment we recommend that you contact your nearest Fenwal Representative. He is equipped to give you further guidance in setting up a good thermal test system.

LIMITED WARRANTY STATEMENT

Fenwal Incorporated represents that this product is free from defects in material and workmanship, and it will repair or replace any product or part thereof which proves to be defective in workmanship or material for a period of twelve (12) months from the date of purchase but not to exceed eighteen (18) months after shipment by the seller. For a full description of Fenwal's LIMITED WARRANTY, which among other things, limits the duration of warranties of MERCHANTABILITY and FITNESS FOR A PARTICULAR PURPOSE and EXCLUDES liability for CONSEQUENTIAL DAMAGES, please read the entire LIMITED WARRANTY on the Fenwal Quotation, Acceptance of Order and/or Original Invoice which will become a part of your sales agreement. Defective units should be returned to the factory, Ashland, Massachusetts, shipment prepaid. Fenwal Incorporated will repair or replace and ship prepaid.

Lubrication

REDUCERS MAY BE FILLED TO THE PROPER LEVEL AT THE FACTORY WITH AGMA No. 8 compounded oil. AFTER INSTALLATION OF THE BREATHER PLUG, UNIT IS READY FOR USE. Before installing breather plug, refer to instruction tag and determine proper position according to reducer mounting.

We recommend an initial oil change after 250 hours of operation, then every six months or every 2500 hours of service under Class I Service. If fluctuating temperatures, humid, dirty or corrosive environment, oil changes should be made more frequently. Frequency can be established by oil sample analysis.

KEEP YOUR OIL CLEAN

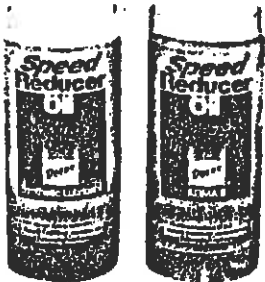

Doerr Electric replacement oil

To order oil, request:

Doerr part no. 00019001 — synthetic AGMA #7EP
(-40°F to 150°F)

Doerr part no. 00019101 — AGMA #8 (50°F to 125°F)

Oil is packed 12 one quart bottles per carton, minimum ship one carton.

Contact DEC Service Dept. for order information.

OIL CAPACITIES*

UNIT TYPE	UNIT SERIES				
	133	175	200	252	325
Worm Over	14	20	27	49	84
Worm Under	17	22	28	49	73
Vertical Output	10	15	20	37	63
"J" Mount	13	18	23	38	63

*Capacities in approximate ounces. On double reduction units determine capacity of both primary and secondary reducers.

OIL LEVELS*

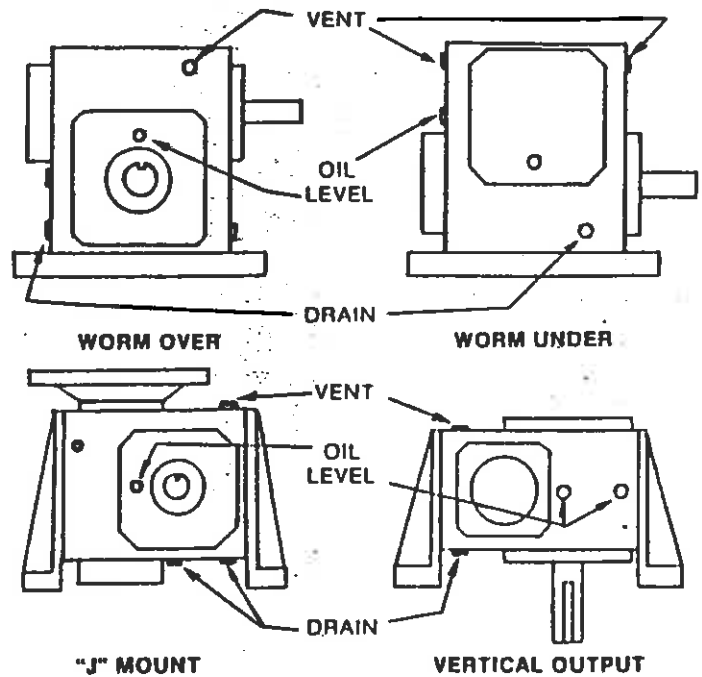

*On double reduction units fill and vent each unit to levels shown.

Motor dimensions

TEFC P/M motor

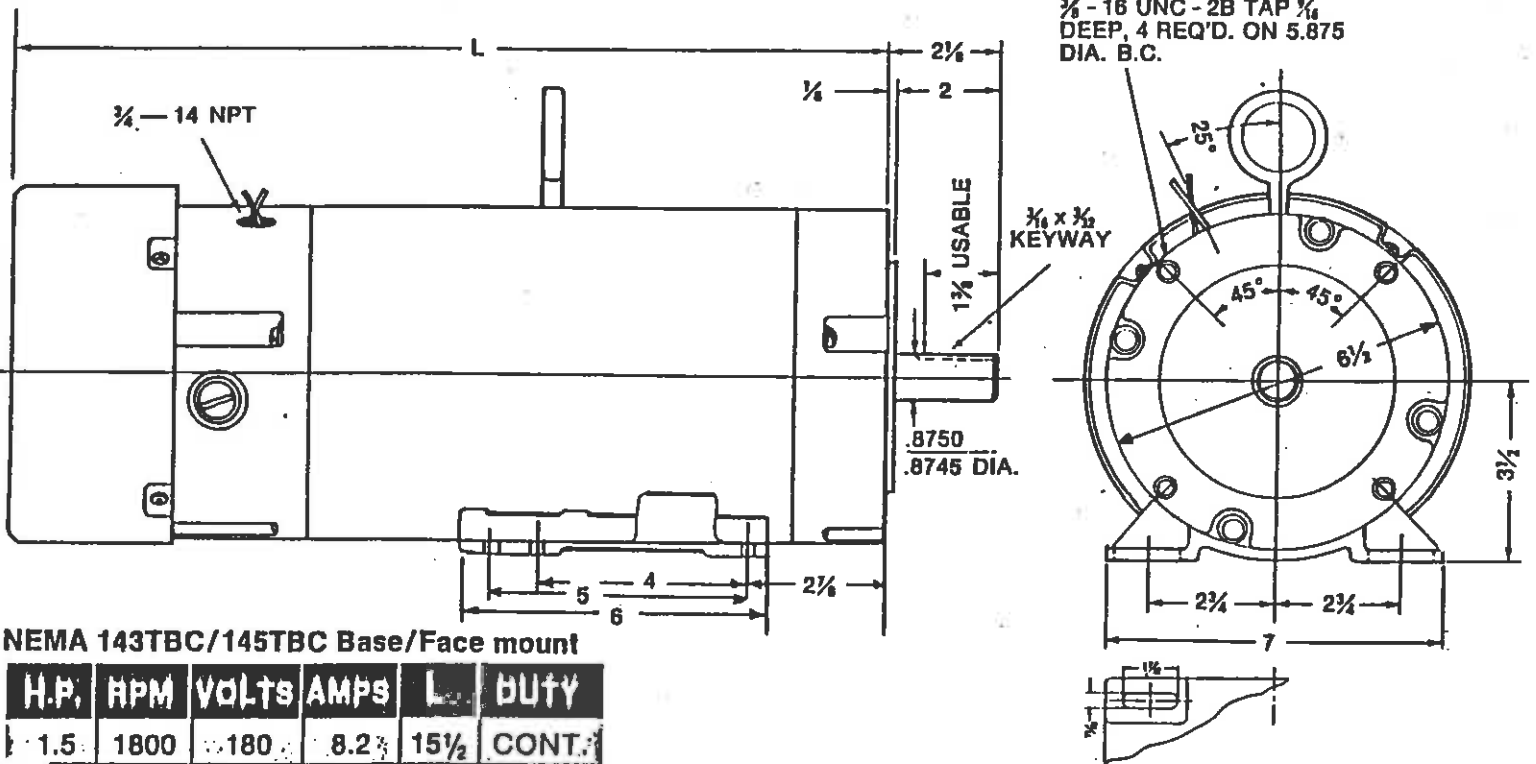

NEMA 143TBC/145TBC Base/Face mount

H.P.	RPM	VOLTS	AMPS	L	DUTY
1.5	1800	180	8.2	15 $\frac{1}{2}$	CONT.
2	1800	180	11.6	16 $\frac{1}{2}$	CONT.

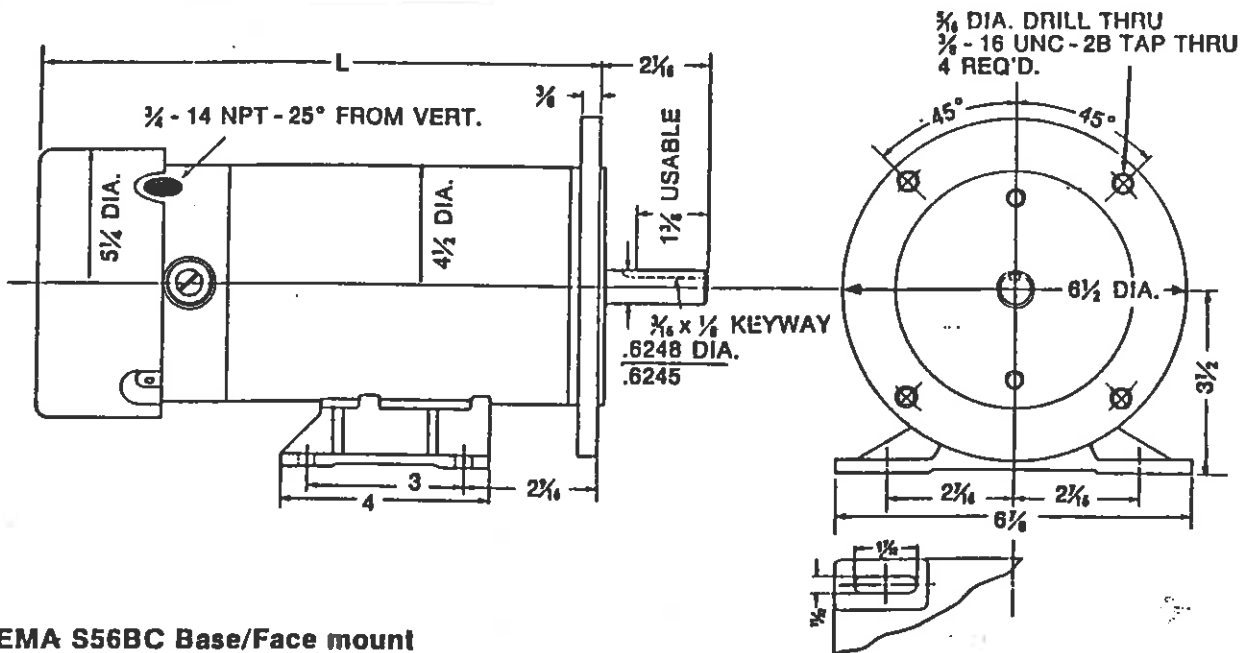

NEMA S56BC Base/Face mount

180 V.

H.P.	RPM	VOLTS	AMPS	L	DUTY
$\frac{1}{2}$	1725	180	2.8	10 $\frac{3}{4}$	CONT.
$\frac{3}{4}$	1725	180	3.5	12 $\frac{3}{4}$	CONT.
1	1725	180	5.35	14 $\frac{3}{4}$	CONT.

90 V.

H.P.	RPM	VOLTS	AMPS	L	DUTY
$\frac{1}{2}$	1725	90	5.35	10 $\frac{3}{4}$	CONT.
$\frac{3}{4}$	1725	90	8.1	12 $\frac{3}{4}$	CONT.
1	1725	90	10.6	14 $\frac{3}{4}$	CONT.

MAINTENANCE INSTRUCTIONS FOR STANDARD REDUCERS

Series 133, 175, 206, 262 and 325

INTRODUCTION

The following instructions apply to standard Worm Gear Reducers. When ordering parts or requesting information specify all information stamped on the reducer nameplate. The nameplate will also identify the type of lubricant to be used.

EQUIPMENT REQUIRED

In addition to standard mechanic's tools, the following equipment is required: arbor press, wheel puller, torque wrench, dial indicator, seal driver, bluing, Permatex No. 2 and Permatex No. 3, snap ring pliers for internal and external rings.

GENERAL INSTRUCTIONS

Housings — Clean external surfaces of reducer before removing seal cages and end covers to prevent dirt from falling into the unit. Record mounting dimensions of accessories for reference when reassembling. If it is necessary to remove the reducer from its operating area, disconnect all connected equipment and lift reducer from its foundation.

Seals — Replacement of all seals is recommended when a unit is disassembled. However, if seals are not to be replaced, protect seal life by wrapping shaft with thin, strong paper coated with oil or grease before removing or replacing seal case assembly. Clean the shaft but do not use any abrasive material on the shaft surface polished by the seal.

CAUTION

If the reducer is painted, extreme care should be taken to mask the shaft extensions and rubber surface of the seals. Paint on the shaft adjacent to the seal or on the seal lip will cause oil leakage.

TO CHANGE OUTPUT SHAFT DIRECTION

To change the hand of a unit from left hand to right hand, or vice versa, the following instructions apply:

1. Remove drain plug and drain oil from unit.
2. Remove end cover and seal cage cap screws; then while supporting output shaft remove end cover and shims from the unit.
3. Remove output shaft and seal cage together from extension side.

NOTE: Keep shims with their respective seal cage and end cover.

4. Insert seal cage, shims and sub-assembly into the housing from the side opposite from which they were removed. Insert seal cage cap screws and tighten with light pressure.
5. Assemble end cover and shims. Insert end cover cap screws and tighten with light pressure.
6. Turn high speed shaft in both directions to see that gear train is running freely.
7. Cross tighten seal cage and end cover cap screws to torques listed in Table 1.

TABLE 1. CAPSCREW TIGHTENING TORQUE

Capscrew Diameter	1/4 - 20 UNC	5/16 - 18 UNC	3/8 - 16 UNC
Torque (in. lbs.) Dry	96	204	360

UNIT DISASSEMBLY, PARTS SERVICE, AND ASSEMBLY

Disassembly:

1. Remove drain plug and drain oil from unit.
2. Low speed shaft (gear shaft) removal:
 - A. Remove end cover and seal cage cap screws.
 - B. With a firm hold on the output extension remove end cover and shims.
 - C. Carefully slide output shaft assembly and seal cage out extension side.
 - D. Slide seal cage off low speed shaft using caution to prevent damage to seal lips.
 - E. Wire or tie the shims to their mating end cover and seal cages. They will be available for reference when assembling the unit.
3. High speed shaft (worm shaft) removal:
 - A. Position unit with input shaft down. With a small chisel make a groove in the stamped steel cover

- B. Remove internal snap ring from housing bore.
- C. Reposition the housing with the worm shaft horizontal. Using a plastic hammer gently tap on the end of the shaft extension to feed worm shaft assembly through housing and out.

Parts Service:

1. **Housing** — Clean inside of housing with kerosene or solvent and then dry.
2. **Seal cages and end cover** — Remove dirt from joint faces, wipe clean and dry.
3. **Air vent** — Wash in kerosene, blow clean and dry.
4. **Seals** — To replace seals without dismantling reducer refer to steps C through F below. To replace seals when the entire reducer is dismantled and coupling hubs, sprockets, pulleys, pinions, keys, etc. have been removed the following instructions apply:

NOTE: Replacement of all seals is recommended when a unit is disassembled.

Caution

New seals will leak if the seal lips or if seal's rubbing surface on the shaft has been altered. Protect seal lips at all times. Clean the shaft but do not use any abrasive material on the shaft surface polished by the seal.

- A. Block up seal cages and press or drive out seal.
- B. Remove old sealing compound from seal seat in cage if it is present. If a seal with rubber coating on the outside diameter is used, no Permatex is necessary. If no rubber coating is on seal outside diameter, coat seal cage bore with Permatex No. 3 or equivalent immediately before assembly. To prevent possible damage to seal lips, do not reassemble seals until high speed and low speed shafts have been reassembled to the housing. Then see steps E and F below.
- C. See Figures 1 through 4—To replace seals without dismantling reducer, proceed as follows:

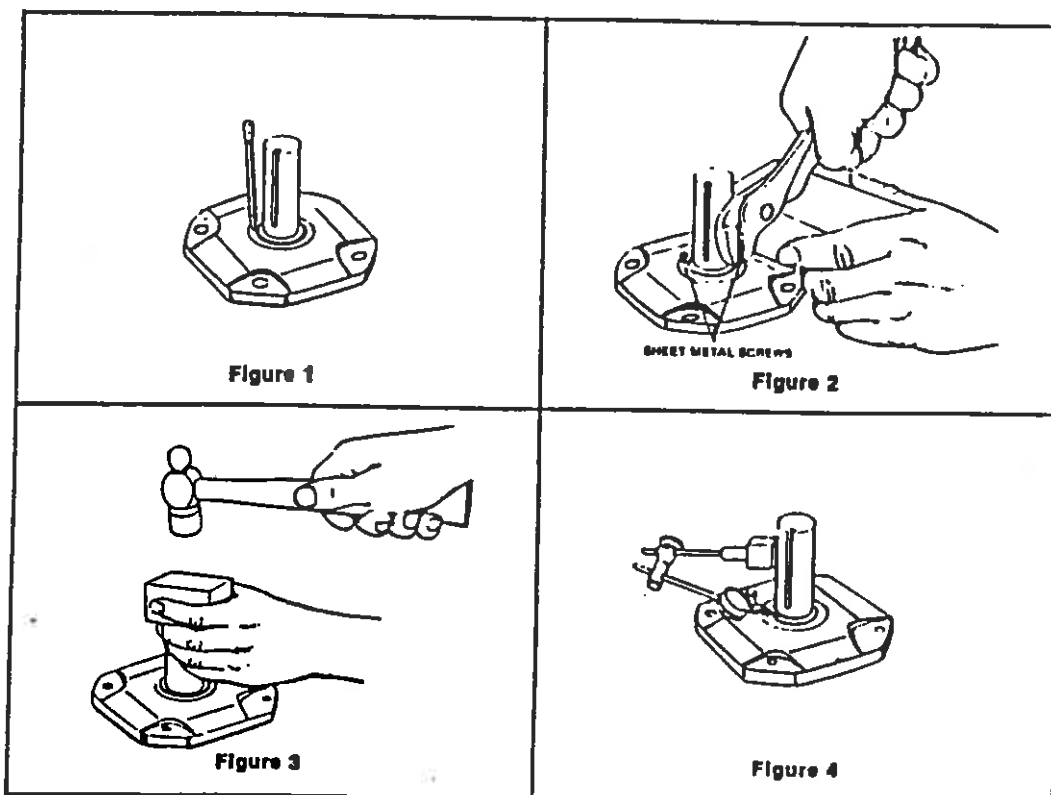

Caution

Do not damage shaft; new seals will leak if seal contacting surface is marred. Use punch and place two or more holes in steel casing of seal, Figure 1. (The steel casing may be rubber coated) Insert sheet metal screws, leaving the heads sufficiently exposed so they can be pried up or grasped with pliers, Figure 2. Do not drill holes because chips may get into the unit.

- D. Work seal loose. Be careful to keep all metal or dirt particles from entering unit. Remove old sealing compound from seal seat if it is present. Also remove burrs and sharp edges from shaft. Clean with rag moistened with solvent. Do not use abrasive material on shaft seal contacting surface.

Caution

- E. Protect seal lips when handling; seal leakage will result if these are damaged. If a seal with rubber coating on the outside diameter (O.D.) is used, no Permatex is necessary. If no rubber coating is on seal O.D., coat seal cage bore with Permatex No. 3 or equivalent. Coat seal lips with oil and carefully work seal into position. Before sliding seal into position, protect seal lips from shaft keyway edges by wrapping shaft with thin, strong paper coated with oil. Position garter spring toward the inside of the unit. Place a square faced pipe or tube against the seal O.D. and drive or press seal until fully seated as shown in Figure 3. Do not strike seal directly.

- F. For best performance, seat the seal square with shaft within .005" at 180°. Check with dial indicator as shown in Figure 4, Page 2, or with a straight edge and feelers, or square and feelers. To straighten a cocked seal, place tubing over the seal and tap the tube lightly at a point diametrically opposite the low point on the seal. DO NOT strike seal directly.

5. Bearings —

- A. Wash all bearings in clean kerosene and then dry.
B. Inspect bearings carefully and replace those that are worn or questionable.
NOTE: Replacement of all bearings is recommended.
C. Use a wheel puller or press to remove worm shaft bearings. Apply force to inner race only — not to cage or outer race.
D. Use a wheel puller or press to remove output bearing inner races.
E. New seal cages and end covers must be used when replacing output bearings. Output bearing outer races must be pressed in square and seated completely.
F. To replace output bearing inner races and all input bearings, heat bearings in an oil bath or oven to maximum of 290 degrees F (143 degrees C). Slide high speed shaft bearings onto the oiled shaft until seated against the shoulder or snap ring of the shaft. Slide low speed shaft bearings onto the oiled shaft against the gear spacer.
G. Thoroughly coat all bearings with lubricating oil.

6. Worm, gear and shafts

- A. Worm and high speed shaft—since all worms are integral with the high speed shaft, any wear or damage to the worm will necessitate replacing both.
B. Press shaft out of bronze worm gear. To reassemble gear and low speed shaft, freeze shaft or heat gear. Do not exceed 200 degrees F (93 degrees C). Insert key into shaft keyway and press shaft into oiled gear bore. The short hub of the gear must be assembled toward snap ring on the shaft.
NOTE: It is advisable to replace both the worm and worm gear should either of the assemblies require replacement.

Unit Reassembly:

1. Preliminary

- A. Check to see that all worn parts have been replaced, gear and bearings coated with oil and all parts cleaned. Remove all foreign matter from unit feet. The feet must be flat and square with each other.
- B. Before starting to reassemble reducer, add old shims or replace with new shims of equal thickness.

2. High Speed Shaft (Worm Shaft) Assembly

- A. Lubricate bearing bores of housing and insert high speed shaft sub-assembly from opposite extension end into housing until seated against shoulder in bore. Tap the end of the shaft lightly with a plastic hammer to feed bearings through bores.
- B. Lock high speed sub-assembly in housing bore with lock ring.
- C. Coat outside diameter of stamped steel end cover with Permatex No. 2 and press into high speed bore opposite extension end until flush with housing. If steel endcover is rubber coated then no Permatex is necessary.

3. Low Speed Shaft (Gear Shaft) Assembly

- A. Determine output shaft direction.
- B. Assemble low speed shaft assembly, seal cage, and end cover with shims on both seal cage and end cover. Torque cap screws to torques listed in Table 1. Rotate the input shaft to seat output bearings.
- C. Moving the shaft back and forth by hand, check axial float with dial indicator as shown in Figure 5. Axial float must be .0005-.003 with .0005 being the absolute minimum. Do not preload bearings. If the axial float is not as specified add or subtract required shims under end cover.

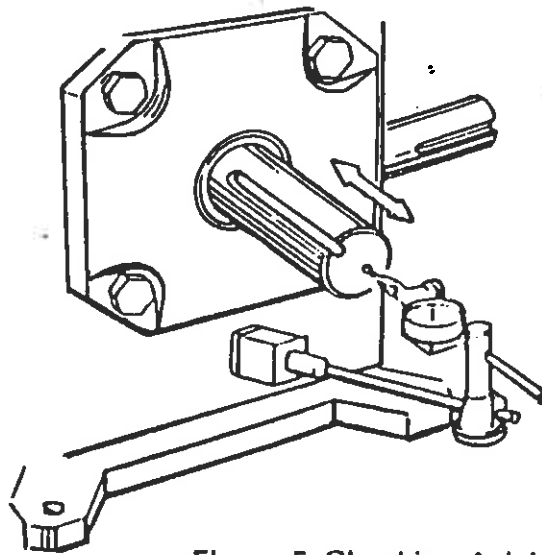

Figure 5 Checking Axial Float

- D. Remove output shaft with seal cage and apply bluing to entire worm thread. Worm thread must be clean of oil. Reassemble output shaft and seal cage with output key facing up.
- E. Use a rag to apply hand pressure to the output shaft and rotate the high speed shaft until output key is down. Return output shaft to original position by reversing rotation. Remove output shaft and seal cage to inspect contact. Compare with Figure 6. If contact is not correct move assembly in the direction shown in Figure 6 by adding shims to the side to which the arrow points after removing them from the opposite side. Repeat steps D and E until contact pattern is correct.
- F. Recheck axial float with dial indicator.
- G. When contact pattern is correct tighten seal cage and end cover cap screws to torques listed in Table 1 page 1.

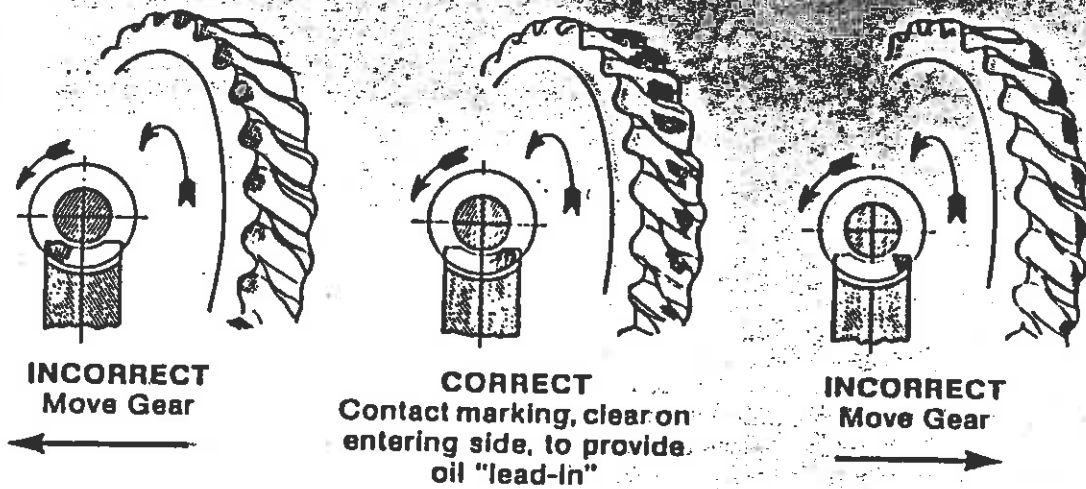

Figure 6. Gear Contact Pattern:

4. **Seals** — To reassemble seals to unit, see Parts Service Steps 4E and 4F, page 3.

5. **Motorized Coupling Adaptor**

Certain mounting dimensions should be adhered to when removing motor and coupling assembly for service. When ordering replacement coupling halves (metal gear), specify correct bore diameter. See Table 2 for mounting dimensions and available bore sizes.

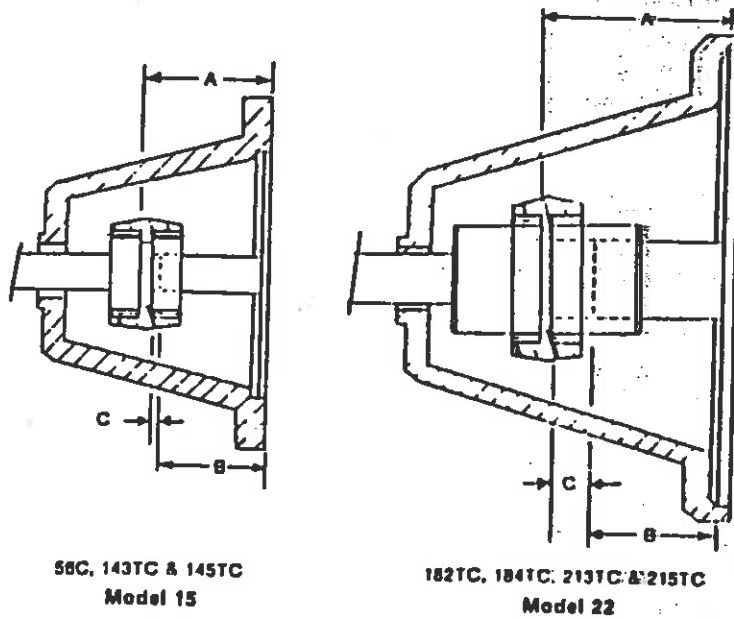

Figure 7 Motorized Coupling Adaptor

TABLE 2. COUPLING ADAPTOR DATA

"C" COUPLING MOUNTING DATA

N.E.M.A. Frame No.	Mounting Dimensions		
	Reducer A ± 1/64	Motor B ± 1/64	C
56C	2 5/16	2 1/16	1/16
143TC	2 5/16	2 1/8	—
145TC	2 5/16	2 1/8	—
182TC	3 5/16	2 5/8	1/2
184TC	3 5/16	2 5/8	1/2
213TC	3 5/16	3 1/8	—
215TC	3 5/16	3 1/8	—

BORE SIZES AVAILABLE

MODEL 15		MODEL 22	
Bore	Kwy.	Bore	Kwy.
.500	None	—	—
.500	1/8 x 1/16	—	—
.625	3/16 x 3/32	.625	3/16 x 3/32
.750	3/16 x 3/32	.750	3/16 x 3/32
.875	3/16 x 3/32	.875	3/16 x 3/32
—	—	1.125	1/4 x 1/8
—	—	1.375	3/16 x 3/32

6. Final Inspection

- A. Turn gear train over by hand as a final check.
- B. Re-install reducer and accessories.

CAUTION: Discard motor key. Use only special key provided with reducer. Failure to use special key will make assembly impossible.

- C. Fill reducer with the recommended oil to proper level. See Fig. 8 for standard oil levels. (Type of oil recommended — see nameplate).
- D. Spin test for three minutes and check for noise, leakage, and rapid temperature rise.

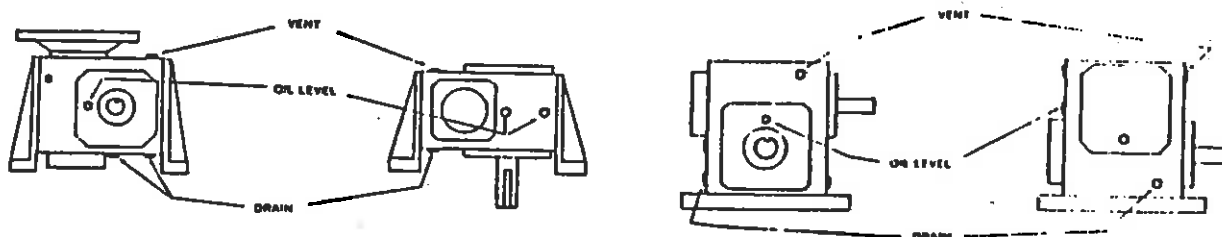

Figure 8 Standard Oil Levels

PREVENTATIVE MAINTENANCE

- A. After first week check all external cap screws and plugs for tightness.
- B. Periodically, check oil level when gears are at rest. Add oil if needed. Do not fill above mark indicated by level because leakage and overheating may occur.
- C. Oil changes — For normal operating conditions, change oil every six months or 2500 hours, whichever occurs first. Also if the unit is operated in an area where temperatures vary with the season, change the oil viscosity to suit the temperature. Most lubricant suppliers can test oil periodically and recommend economical oil change schedules.

CAUTION

See nameplate for type of lubricant to be used.

STORED AND INACTIVE UNITS

1. Each unit is shipped with oil that will protect parts against rust for a period of 4 months in an outdoor shelter or 12 months in a dry building after shipment from the factory. Indoor dry storage is recommended.
2. If a unit is to be stored or is to be inactive after installation beyond the above periods, fill the unit completely with oil.

CAUTION

Before starting a stored unit or re-starting an inactive unit, the oil level should be returned to the proper value as indicated by the oil level.

PARTS ORDERING INSTRUCTIONS

When ordering replacement parts first locate the exploded view that corresponds to your Doerr Electric gear reducer. Then determine which parts must be ordered. To order the parts, please provide the following:

1. Complete Model Number (Nameplate)
2. Item Number (Exploded view and parts list)
3. Part Description (Parts list)

Note that one parts list covers all five exploded views. Although a single item number may refer to the same part on all five exploded views, it is incorrect to assume that these parts are interchangeable. They are not. Therefore, it is imperative that items 1 through 3 above be provided when ordering your parts.

Failure to provide this information will only slow or prevent the processing of your order.

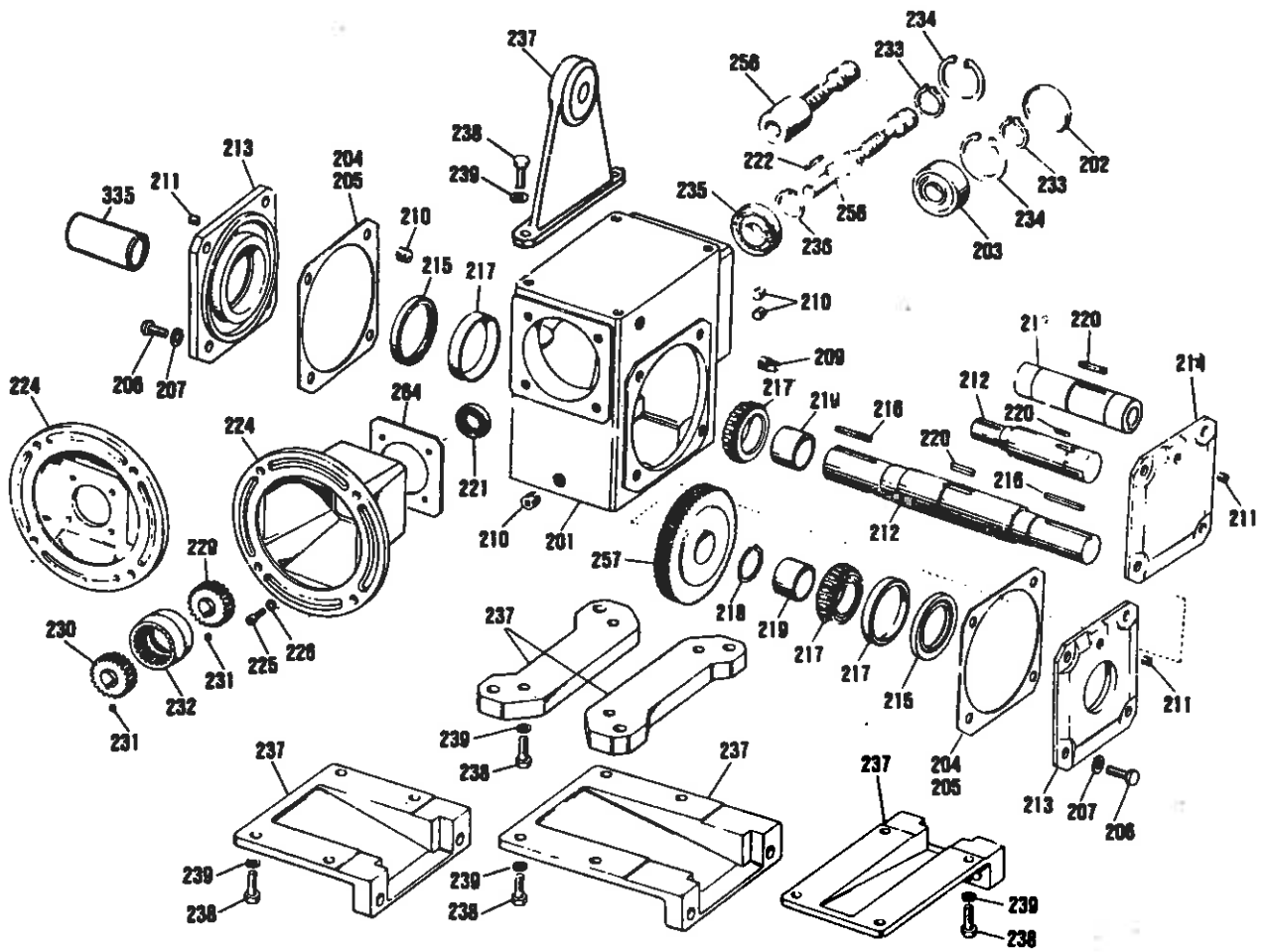

Single Reduction Unit 133, 175, 206 Series

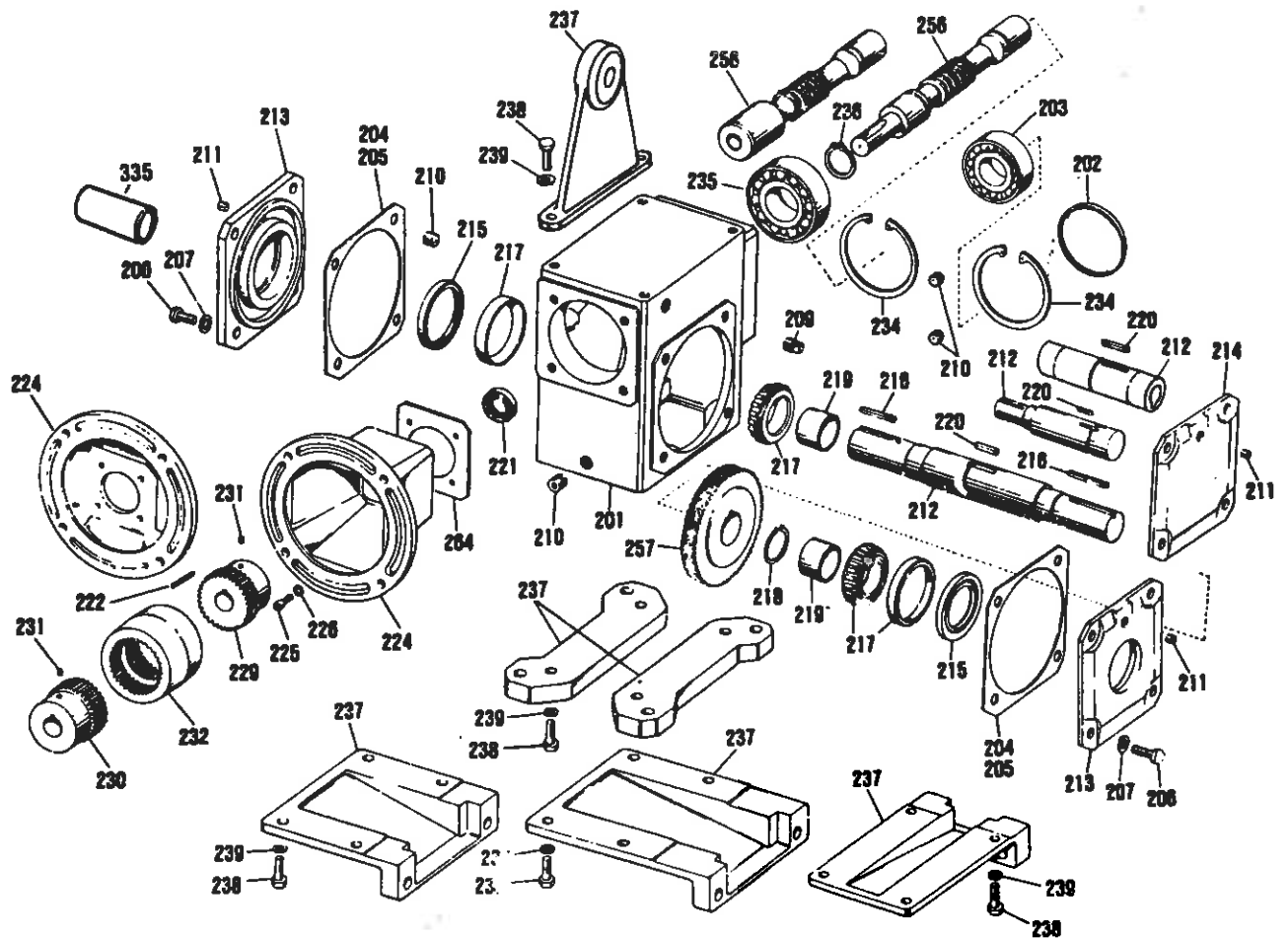

Single Reduction Unit 262, 325 Series

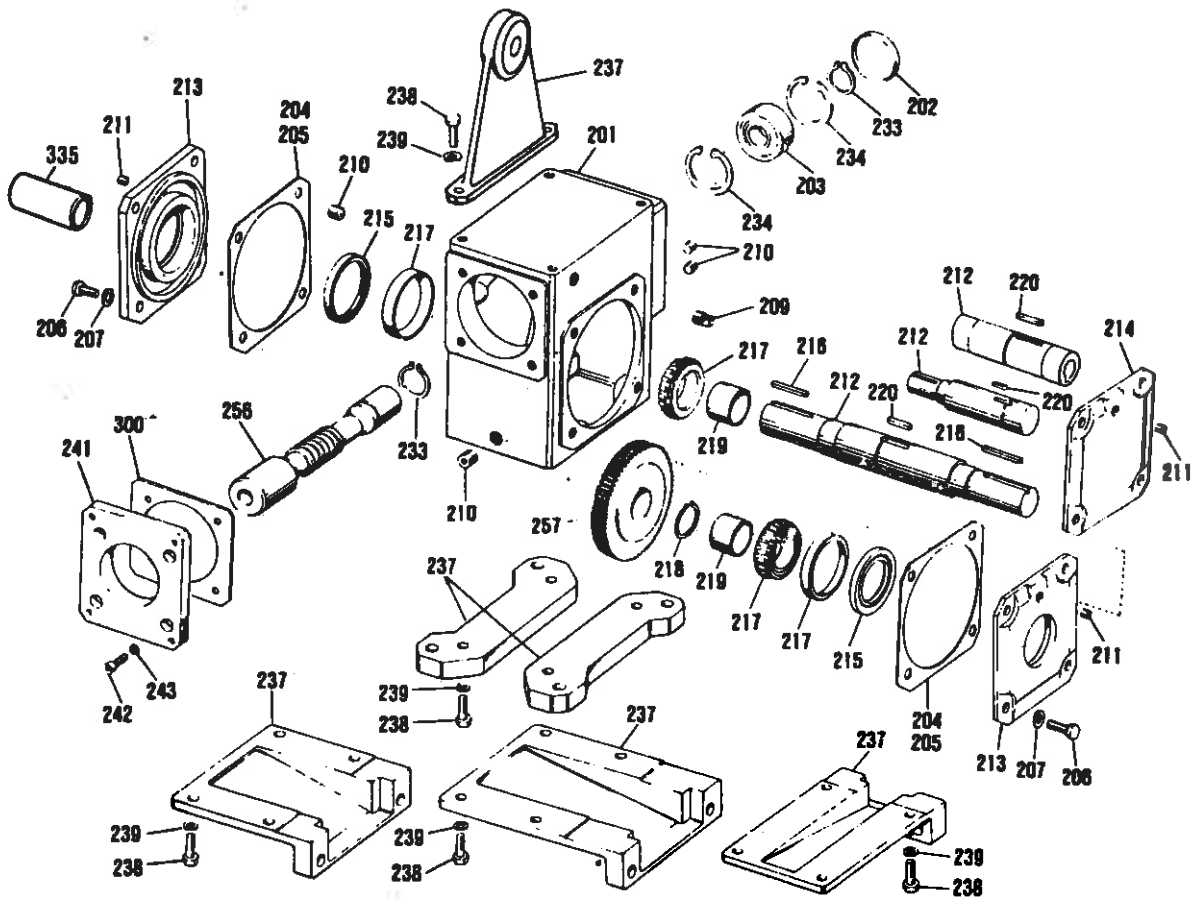

Double Reduction Secondary Unit 133, 175, 206 Series

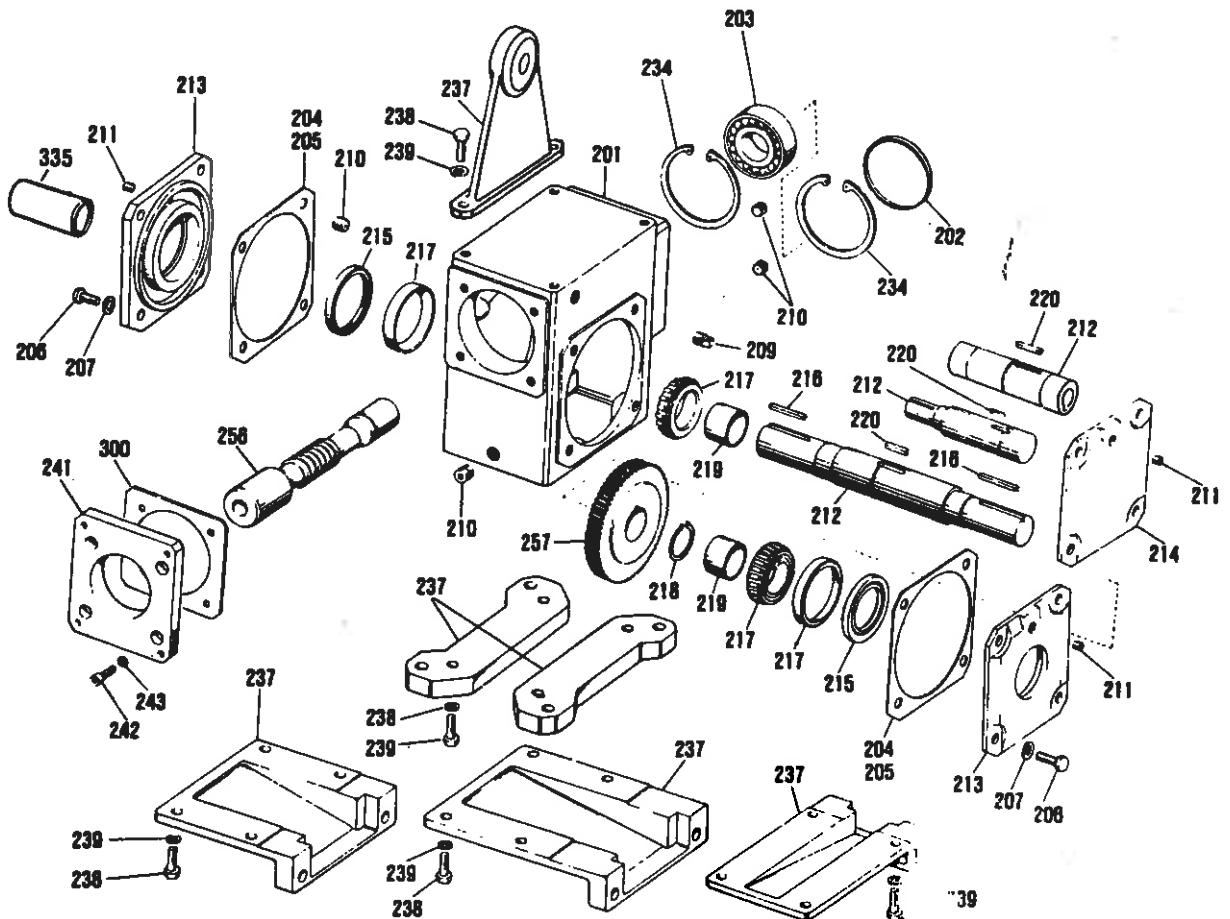

Double Reduction Secondary Unit 262, 325 Series

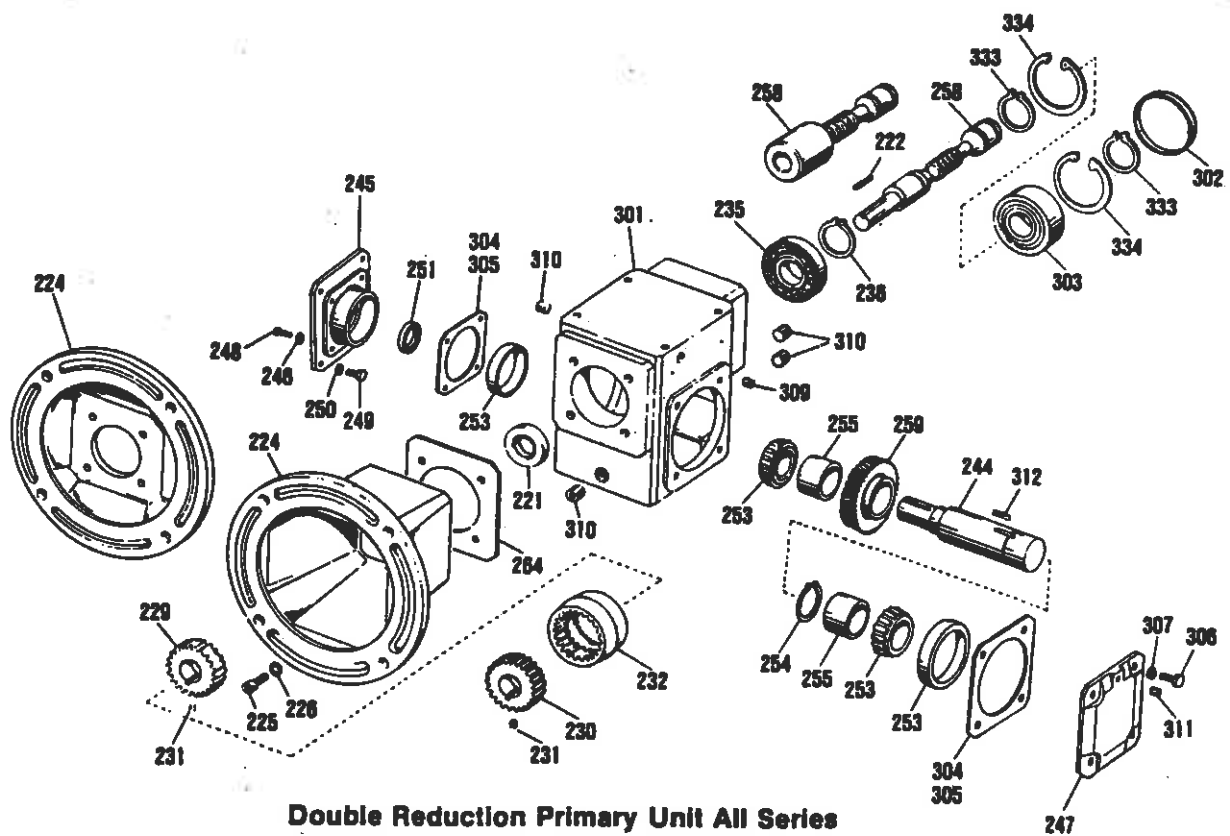

Double Reduction Primary Unit All Series

PARTS LIST
(Applies to all exploded views)

ITEM	DESCRIPTION	ITEM	DESCRIPTION	ITEM	DESCRIPTION
201	Housing	229	Coupling Hub (Unit)	255	Spacer
202	End Cover	230	Coupling Hub (Motor)	256	Worm
203	Bearing	231	Setscrew	257	Gear
204	Shim (.019 Thick)	232	Coupling Sleeve	258	Worm
205	Shim (.007 Thick)	233	Lock Ring	259	Gear
206	Capscrew	234	Lock Ring	260	Thrust Plate
207	Lock Washer	235	Bearing	261	Capscrew
209	Vent Plug	236	Lock Ring	264	Gasket
210	Pipe Plug	237	Base	300	Gasket
211	Pipe Plug	238	Capscrew	301	Housing
212	Output Shaft	239	Lock Washer	302	End Cover
213	Seal Cage	241	Secondary Adaptor	303	Bearing
214	End Cover	242	Capscrew	304	Shim (.019 Thick)
215	Oil Seal	243	Lock Washer	305	Shim (.007 Thick)
216	Key	244	Primary Output Shaft	306	Capscrew
217	Bearing	245	Primary Adaptor	307	Lock Washer
218	Lock Ring	246	Lock Washer	309	Vent Plug
219	Spacer	247	End Cover	310	Pipe Plug
220	Key	248	Capscrew	311	Pipe Plug
221	Oil Seal	249	Capscrew	312	Key
222	Key	250	Lock Washer	333	Lock Ring
224	Motor Flange	251	Oil Seal	334	Lock Ring
225	Capscrew	253	Bearing	335	Shaft Cover
226	Lock Washer	254	Lock Ring		

Note: When ordering replacement parts, specify model number, item number, and part description.