

ATTENTION:

VERY IMPORTANT

Before unloading and unpacking the stretchwrapper read carefully section 5 of this manual for unloading and unpacking instructions.

Failure to do so may result in the forfeiture of the warranty.

ORION PACKAGING INC.

NOTICE

In order to acquire more information about custom make features of the machine; and to provide quicker service, the following information is required when making an inquiry for a machine:

- 1) Serial Number
- 2) Model Number
- 3) Subassembly-Part Location

ORION PACKAGING INC.

H55
Owner's Manual

ORION PACKAGING INC.
2270 Industriel
Laval, Quebec H7S 1P9

Telephone: (514) 667-9769
Fax: (514) 667-6320

ORION PACKAGING SYSTEMS, INC.
DISTRIBUTOR PRICE LIST - EFFECTIVE NOVEMBER 1, 1989

ORION MODEL H-55/6R serial no:0111862

Spiral Semi-Automatic Heavy Duty High Profile

Maximum Load Size 55"W x 55"L x 80"H (Recommended)
60"W x 60"L x 84"H (Theoretical)*

Weight Capacity 6,000 lbs. dynamic, 20,000 lbs. static

Utilities 115/1/60 20 Amp Electrical Service

Turntable 52" x 52" Formed 3/8" Steel Plate
4 Support Casters 6" x 2-1/2" Steel
Precision Tapered Caster Bearings
13-1/2" Height to Top of Turntable

Turntable Drive 0-12 RPM Variable Turntable Speed
1/2 HP DC Drive Motor
#50 Roller Chain Drive with Tensioner
Electronic Soft Start
Positive Alignment Feature

Control Features Electronic Film Force Control
Separate Top and Bottom Wrap Selectors
Variable Speed Film Carriage Control
Auto-Height Photocell w/On/Off Switch
Film Carriage Raise/Lower Switch
Turntable Jog Pushbutton
Spiral Up or Up/Down Cycles
Current Overload Protection
NEMA 12 Electrical Enclosure

Film Delivery 20" Orion MultiStretch Power Prestretch
Electronic Film Tension Control
End of Cycle Film Force Release
Full Authority Film Dancer Bar
Chain & Sprocket Stretch Ratio Control
1/2 HP DC/SCR Film Drive

Film Carriage Drive #50 Roller Chain Carriage Lift
1/2 HP Elevator Drive Motor
Variable Speed SCR Control
Structural "H" Channel Guidance
Precision Cam Follower Tracking

Structural Features Heavy Structural Steel Tubing Design
Forklift Portable Base Design
Film Roping Bar
8" x 31 lb./ft. "H" Channel Mast

Est. Shipping Weight 1,800 lbs.

*Theoretical is based upon removal of roping bar, and
reflects maximum film web height attainable

ORION PACKAGING INC.

ALL SERIES EXCEPT "M"

ORION PACKAGING INC.

DISTRIBUTOR PRICE LIST - EFFECTIVE NOVEMBER 1, 1989

SEMI-AUTOMATIC MACHINE OPTIONS

AUTO-HEIGHT PHOTOCCELL

77 series.....

LOADING RAMPS FOR LOW PROFILES

L77/66.....

L55S/44S.....

L55/44.....

L66-72.....

MACHINE BASE EXTENSIONS (MAX. 3 FT)

H77/66 (per foot).....

L77/66 (per foot).....

H55/44 (per foot).....

L55/44 (per foot).....

L55S/44S (per foot).....

MACHINE MAST EXTENSIONS (MAX. 3 FT)

All Series (Except "M") (first foot).....

(each additional foot).....

M77/67/66 (per foot).....

M57/55 (per foot).....

M44 (per foot).....

HINGED TOWER (FOR TRANSPORT IN LOW TRUCKS)

All Series (Except "M").....

ORION PACKAGING INC.
DISTRIBUTOR PRICE LIST - EFFECTIVE NOVEMBER 1, 1989

SEMI-AUTOMATIC MACHINE OPTIONS

PNEUMATIC TOP PLATENS

36" circular platen with 24" stroke.....
36" circular platen with 36" stroke.....
48" x 48" square platen with homing.....
device, and 36" stroke
48" x 48" square platen with homing.....
device, and 48" stroke

TRANSFORMER

To accept 430/60 or 575/60.....
For each additional conveyor section.....

DUAL TURNTABLE OPTION

L66.....
H66.....
L55/44.....
H55/44.....
L55S/44S.....

NOTE: Dual Turntable options includes second
turntable with all drive components &
controls, second auto-height photocell,
and table selector switch.

NOTE: When a ring gear/pinion gear turntable
drive is required, the cost of 2 ring
gear options must be added to the dual
turntable option price.

RING GEAR/PINION GEAR TURNTABLE DRIVE

H66....(20" DIA.).....
H55....(25" DIA.).....
H44....(33" DIA.).....

Central lubrication point for ring gear.....

ORION PACKAGING INC.

DISTRIBUTOR PRICE LIST - EFFECTIVE NOVEMBER 1, 1989

SEMI-AUTOMATIC MACHINE OPTIONS

PROGRAMMABLE LOGIC CONTROLLER OPTIONS

66/55 Series - Allen Bradley SLC-100.....
44 Series - Allen Bradley SLC-150.....
EEPROM ordered with machine.....
EEPROM ordered after shipping of the machine.....

CYCLE COUNTER (inside control panel).....

TURNTABLE OPTIONS

0-12 RPM Variable Speed Turntable Drive for.....
L/H 77 Models
0-12 RPM Variable Speed Turntable Drive with.....
Positive Alignment Feature for L/H 77 Models
10,000 lb Capacity (H55/44).....
8,000 lb Capacity (L55/44).....
10,000 lb Capacity (L55/44).....
Anti-Skid Surface.....
72" dia. round, 3/8" with 4" skirt (H55/44).....
72" dia. round, 1/2" (L44/44S,L55/55S).....
72" dia. round, 1/2" (L66).....
72" dia. round, 3/8" (L66).....
60" dia. round, 1/2" (L66/55/44).....
Reinforced Concentric Rings.....
Remote Pull Switch.....
Filler Plate (H77/66).....
Filler Plate (H55/44).....

ORION PACKAGING INC.
DISTRIBUTOR PRICE LIST - EFFECTIVE NOVEMBER 1, 1989

SEMI-AUTOMATIC MACHINE OPTIONS

COLD TEMPERATURE OPTIONS (-20 F)

Heated Control Enclosure, Silicon Rubber Wiring.....
and Special Lubricant in Reducers

CONVEYOR OPTIONS

IDLER ROLLER (NON-DRIVEN)

72" Dia. idler roller turntable for H66/55/44.....
(On H-66, requires ring gear option and
max. wt. 2,500 lbs) Rollers are 3.5" Dia.
on 4.5" centers, with manual brake.

72" Dia. idler roller turntable for L55S/44S.....
Rollers are 3.5" Dia. on 4.5" centers, with
manual brake.

Pneumatic Roller Brake for "L" Series.....

Pneumatic Roller Brake for "H" Series.....

5' Length CONTOURED Idler Roller Conveyor,.....
3.5" Dia. Rollers on 4.5" Centers, 50" Wide
Roller Face.

5' Length STRAIGHT Idler Roller Conveyor,.....
3.5" dia. rollers on 4.5" centers,
50" wide roller face.

POWERED ROLLER

55 STYLE (Powered Roller Turntable)

76" Dia. powered roller TURNTABLE, Rollers.....
rollers 3.5" dia. on 4.5" centers, all full
length driven. Includes 1/2 hp AC drive,
adjustable speed. Wall tubing 1/8"
(H55/44 only - requires ring gear option)

ORION PACKAGING INC.
DISTRIBUTOR PRICE LIST - EFFECTIVE NOVEMBER 1, 1989

SEMI-AUTOMATIC MACHINE OPTIONS

44 STYLE (Powered Roller Turntable)

76" Dia. Powered Roller TURNTABLE, Rollers.....
3.5" Dia. on 4.5" Centers, All Full Length
Driven. Includes 1/2 hp DC Drive, Adjust-
able Speed. Wall Tubing 3/16", Cast Iron
Pillow Blocks. (NOTE: H55/44 only, requires
RING GEAR OPTION)

55 STYLE (CONTOURED Powered Roller Conveyor)

5' Length CONTOURED Powered Roller Conveyor,.....
3.5" Dia. Rollers on 4.5" Centers, 50"
Effective Width; All Full Length Rollers
Driven. Includes 1/2 hp AC Drive, Non-
Reversing. Wall tubing 1/8"

44 STYLE (CONTOURED Powered Roller Conveyor)

5' Length CONTOURED Powered Roller Conveyor,.....
3.5" Dia. Rollers on 4.5" Centers, 52"
Effective Width, All Full Length Rollers
Driven, Cast Iron Pillow Blocks.
Includes 1/2 hp DC Drive, Variable
Speed, with Soft Start.

Automatic Sequencing, Logic and Photocell.....
For Powered Conveyor (Per Section) - Includes
Photocell PLC Input and Output/Program.

Turntable Mechanical Home Position Lock.....
(Pneumatic, Positive Lock)

ORION PACKAGING INC.
DISTRIBUTOR PRICE LIST - EFFECTIVE NOVEMBER 1, 1989

SEMI-AUTOMATIC MACHINE OPTIONS

FILM CARRIAGE OPTIONS

- Double #60 Chain Carriage Lift.....
- 20" Multistretch Retrofit Carriage.....
(For Installation on Existing Machines)
- 30" Multistretch Retrofit Carriage.....
(For Installation on Existing Machines)
- 30" Multistretch Carriage Upgrade from 20".....
on H66/55/44 and L66/55/66.
- 30" Multistretch Carriage Upgrade from 20".....
on M66/55/44.
- 30" Econostretch Carriage Upgrade on 77
Series from 20".

ELECTRONIC SCALE PACKAGE OPTION

Includes Heavy Duty Load Cells Incorporated.....
into the Machine or Conveyor Frame, Protected
from Lateral Shock, and a Digital Display of
Load Weight, with RS-232C Port, Gross, Net
Tare, Zero.

NOTE: On L-77 and L-66 models, scale option
reduces machine capacity to 2500 lbs.,
unless base reinforcement option is
ordered.

Base Reinforcement on L-77 or L-66 models,.....
when 4000 lbs capacity is desired with
scale package.

4.1 Tower Parts List

The exploded assembly drawing of the Standard Tower is shown on drawing number 200 99. Table 1 has the parts listed in order of part number. Note: the names given to the parts are generic.

TABLE 1

Tower Parts List

Part Number	Description	Quantity
10008	Idler sprocket	1
10009	#50 chain	1
10010	Cam follower (1 3/8 inch O.D.)	6
10018	Left carriage holder	1
10019	Right carriage holder	1
10063	Tower	1
10067	Cam follower (1/2 inch O.D.)	4
10069	Chain tensioner	1
10070	Chain tensioning screw	2
10071	Limit switch actuator	1
10074	Drive sprocket	1
10076	Limit switch channel	1
10081	Chain cover	1
10087	Limit switch bracket	3
10091	Channel guide	3



10092	Knob	3
10093	Reducer	1
10095	Elevator motor (1/2 hp, 1750 rpm)	1
10123	Limit switch	3
10288	1/4-20 UNC x 1/2 SHCS	2
10289	Limit switch screw	6
10290	Channel screw (1/4-20 UNC x 1/2 SHCS)	2
10291	Transmission screw (3/8-16 UNC x 1 Hex bolt)	4
10292	Chain tensioner pin	2
10293	3/8-16 UNC x 3/4 Hex bolt	2
10294	Cover screw (1/4-20 UNC x 1/2 SHCS)	3
10295	3/16 inch square key	1

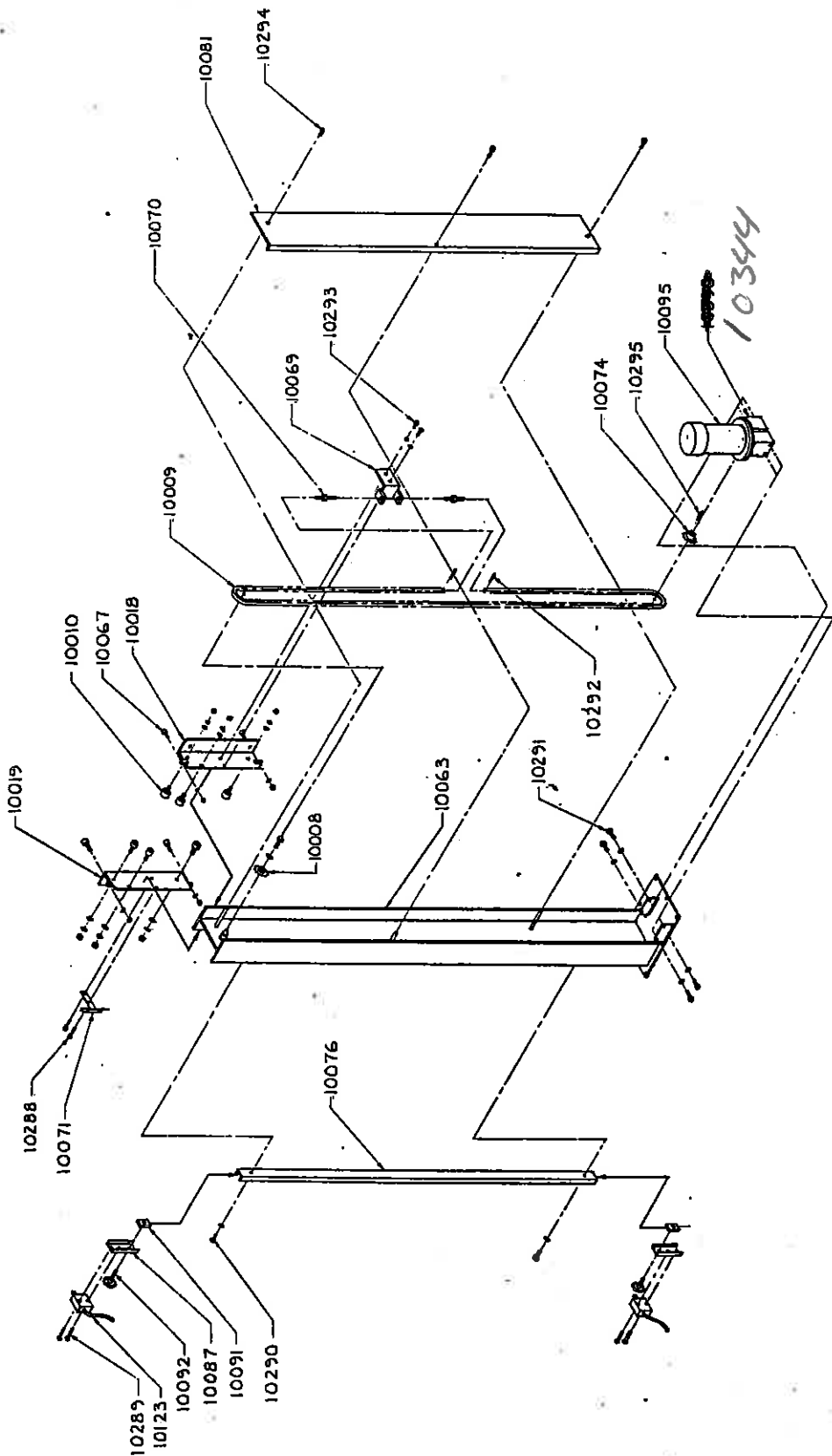

10344

This is
 9 H 55/6 Manual
 27-6-1996

ORION PACKAGING MONTREAL	
M.F.S.	DATE
27-6-96	
STD. TOWER ASST	
L44	K44 LES MSS PAS3
REV. 99	

CARRIAGE PARTS LIST

<u>Orion P/N</u>	<u>Description</u>	<u>Qty</u>
10036	Electric motor 1/2HP, 90 VDC, 1750 RPM	1
10047	Tension spring	2
10049	Brake pads 1/4" thk	2
10049	Brake disk	1
10050	Film spool mandrel for 20" film	1
10051	Mandrel, top	1
10052	Collar 1"	3
10058	Bushing, bronze	2
10156	Photoswitch bracket (left hand)	1
10157	Pillow block assembly 3/4"	6
10199	Washer	1
10583	Chain #40	1
10825	Back plate for 20" film	1
10885	Bottom spool mandrel	1
10886	Spool spike	2
10891	Compression spring	1
10892	Shoulder screw 5/16" dia x 3/8" long	2
10946	Plastic hose	2
10968	Drive sprocket for std - 175%	1
10975	Drive sprocket	1
11003	Pulley	1
11142	Chain tensioner	1
11151	Timing belt	1
11152	Photocell channel for 20" film	1
11153	Channel guide	1
11253	C/L #40	1
11283	Timing belt pulley	1
11297	Sprocket	1
11366	Hex head screw 5/8-18UNF x 1 1/2" long	2
11369	Top bracket	1
11370	Lever	2
11371	Roller 2 1/4" long	2
11406	Rubber roller 4" dia x 21"	1
11407	Rubber roller 4" dia x 31"	1
11408	Rubber roller 2.66" dia x 21"	1
11409	Rubber roller 2.66" dia x 31"	1
11410	Rubber roller 1 3/4" dia x 21"	1
11411	Rubber roller 1 3/4" dia x 31"	1
11416	Bottom bracket standard	1
11419	Roller shaft for 20" film	1
11420	Roller shaft for 30" film	1
11421	Dancer roller for 20" film	1
11422	Dancer roller for 30" film	1
11425	3/8-16UNC threaded rod 2" long	2
11430	Back plate for 30" film	1
11431	Roller 31" long	2
11432	Photocell channel for 30" film	1

CARRIAGE PARTS LIST

<u>Orion P/N</u>	<u>Description</u>	<u>Qty</u>
11446	Photocell bracket (right hand)	1
11470	Proximity sensor	1
11476	Proximity sensor bracket	1
11477	Proximity sensor cam	1

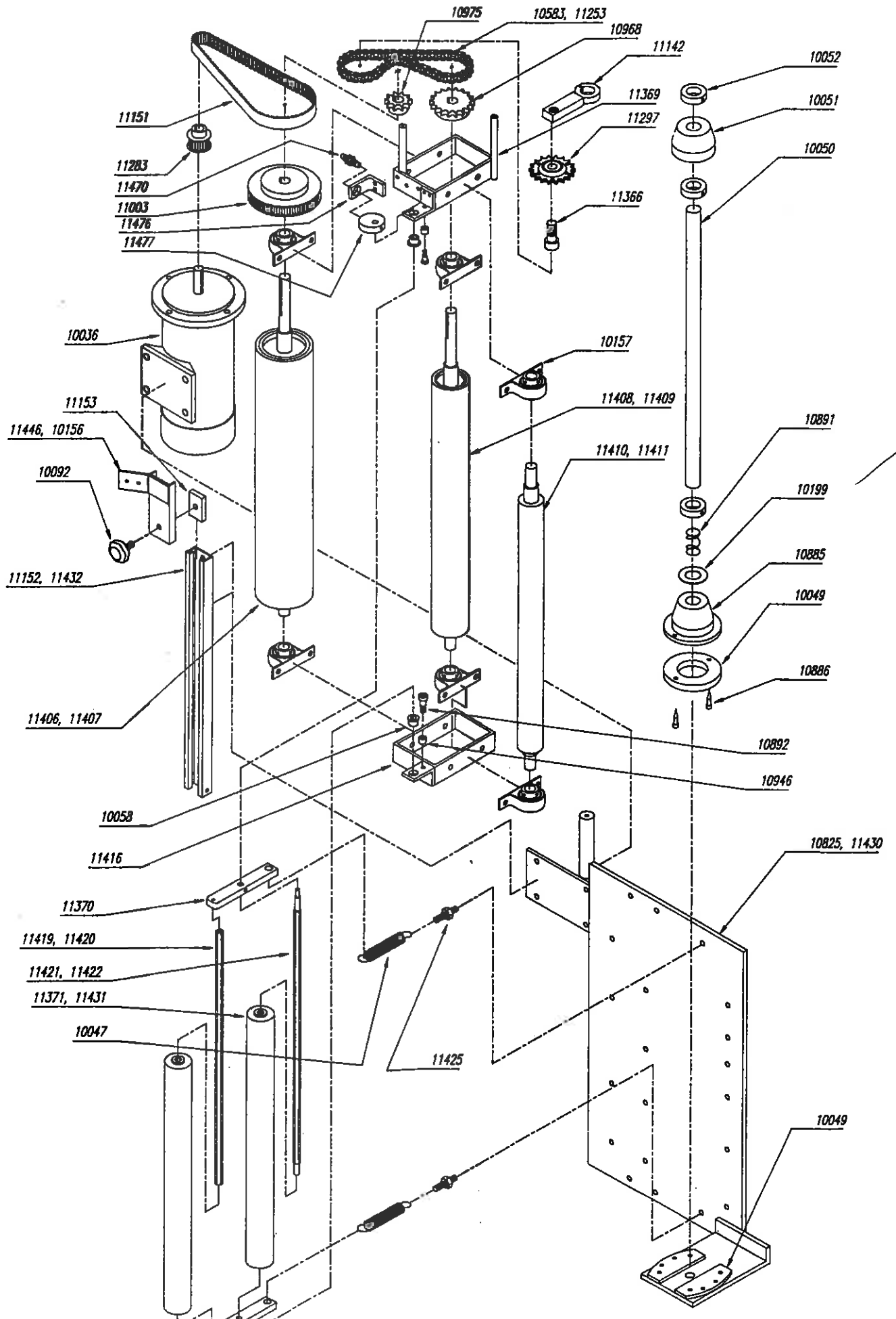

4.3 Base And Turntable Parts List

The exploded assembly drawing of the Standard, High Profile base is shown on drawing number 200 101. Table 3 has the parts listed in order of part number. Note: the names given to the parts are generic.

TABLE 3

Base And Turntable Parts List

Part Number	Description	Quantity
10006	Turntable sprocket	1
10007	Center bearing unit	1
10009	#50 chain	1
10032	3/4 hp DC motor (H44)	1
10035	Reducer	1
10036	1/2 hp DC motor (H55)	1
10091	Channel guide	1
10092	Knob	1
10116	Proximity switch	1
10196	Tapered roller bearing	8
10197	Caster	4
10198	Caster shaft	4
10199	Caster washer	12
10200	Caster shaft nut	4
10201	Channel stand	1
10202	Proximity switch channel	1
10203	Proximity switch bracket	1
10219	Base	1



10220	Turntable	1
10221	Driver sprocket (H44)	1
10222	Driver sprocket (H55)	1
10225	Drive console	1
10311	1/2-13 UNC x 1 long hex bolt	4
10312	3/8-16 UNC x 1 1/2 long hex bolt	4
10313	3/8-16 UNC x 1 long hex bolt	4
10314	Roping bar	1
10315	3/8-16 UNC x 1 long hex bolt	2
10316	5/16-18 UNC x 1 long hex bolt	6
10317	Cotter pin	4
10318	5/16-18 UNC x 1 long hex bolt	4
10319	3/8-16 UNC x 1 1/2 long SHCS	4
10320	Roping bar stand	2

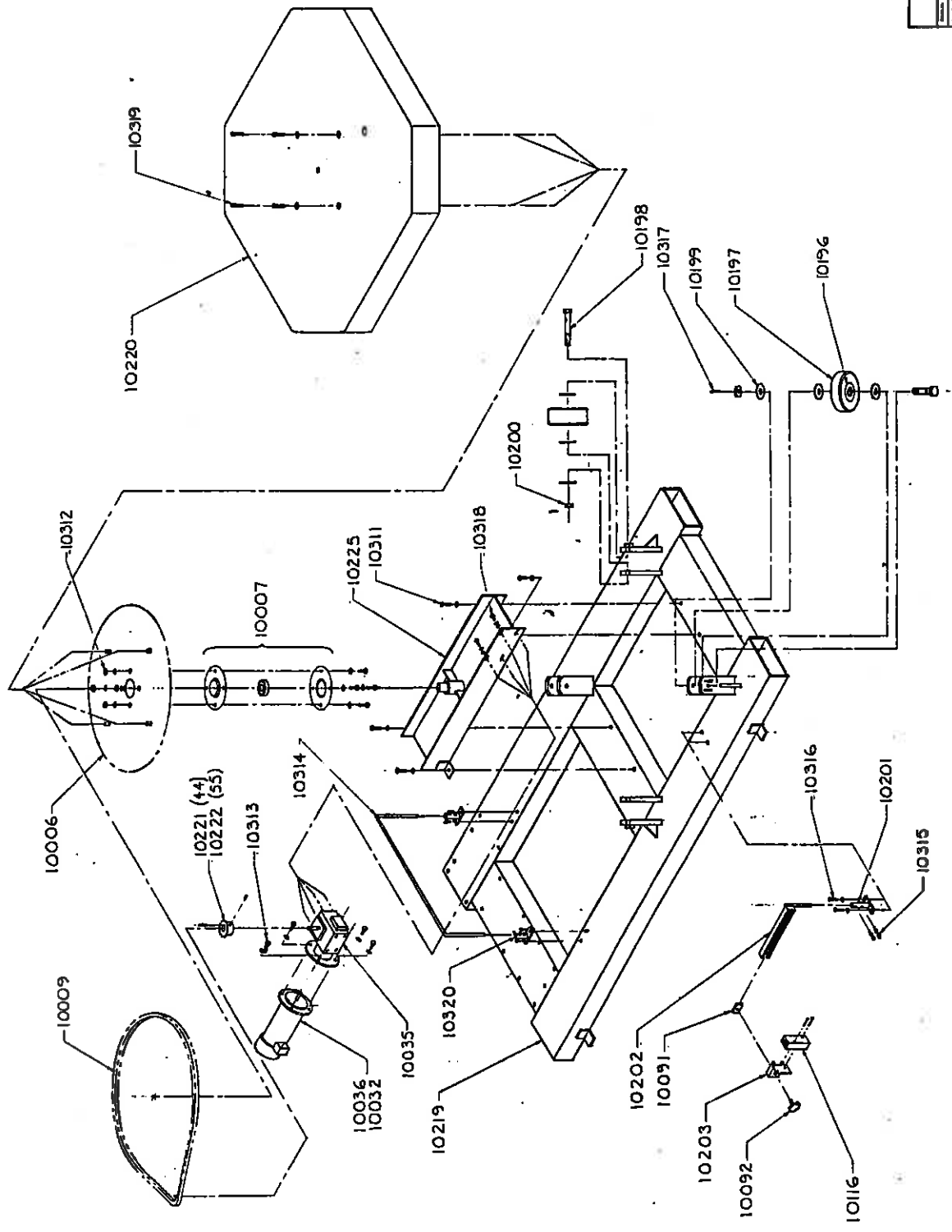

ORION PACKAGING INC.
BASE AND TURNTABLE SUBASSEMBLY PARTS LIST

MODEL H55R

ORION P/N	DESCRIPTION	QTY
10035	Reducer (BQ175, 15:1, assy 2)	1
10036	Motor (1/2 hp, 90vdc, 1750 rpm)	1
10091	Channel Guide	1
10092	Knob	1
10201	Proximity Switch Stand	1
10202	Proximity Switch Channel	1
10203	Proximity Switch Holder	1
10739	Proximity Switch	1
10799	Base	1
10800	External Ring Gear (33" dia., 138 teeth)	1
10803	Pinion Gear (19 teeth, module 6)	1
10805	Turntable (52"x52" formed, 3/8" steel plate)	1

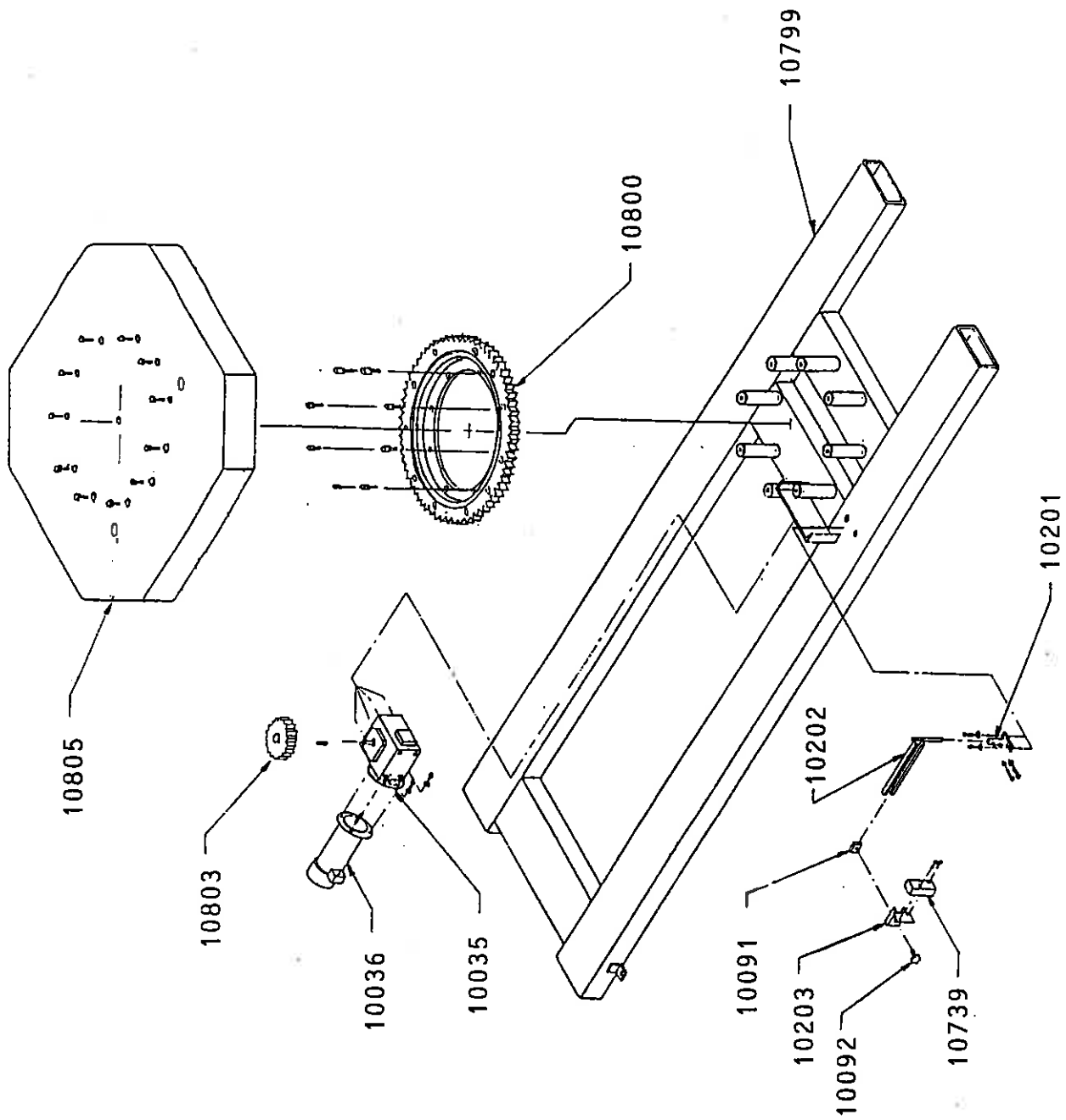

BASE AND TURNTABLE SUBASSEMBLY - H55R

5. MACHINE INSPECTION AND INSTALLATION

5.1 Inspection Upon Arrival

CAUTION: When unloading the stretchwrapper, care must be taken not to lift it by the turntable. The forks of the forklift should be inserted in the 10 x 4 structural tube steel members in the base to lift the machine.

Before inspection, all packing and restraining blocks must be removed; these may include the blocks under the carriage and the restraining bar over the table.

CAUTION: When cutting the stretchwrap material covering the machine, care must be taken not to cut any of the electrical lines.

A visual inspection of all the electrical connections should be performed after unpacking the machine to check for loosened joints or broken connections. Any suspected shipping damage must be reported immediately to the freight carrier.

Items that are vulnerable to damage and must be inspected are the motor and transmission housings and connections under the turntable, at the base of the tower, and on the carriage. Also vulnerable are the roping bar and roping bar stands, and the photocell on the carriage.

5.2 Machine Installation

After the visual inspection has been performed, the customer is required to provide the electrical power requirements as outlined in the specifications (sections 1, 2, and 3 of this manual).

An electrical diagram is provided in the panel box. Only a qualified electrical technician or an Orion representative should effect any repairs on the machines.

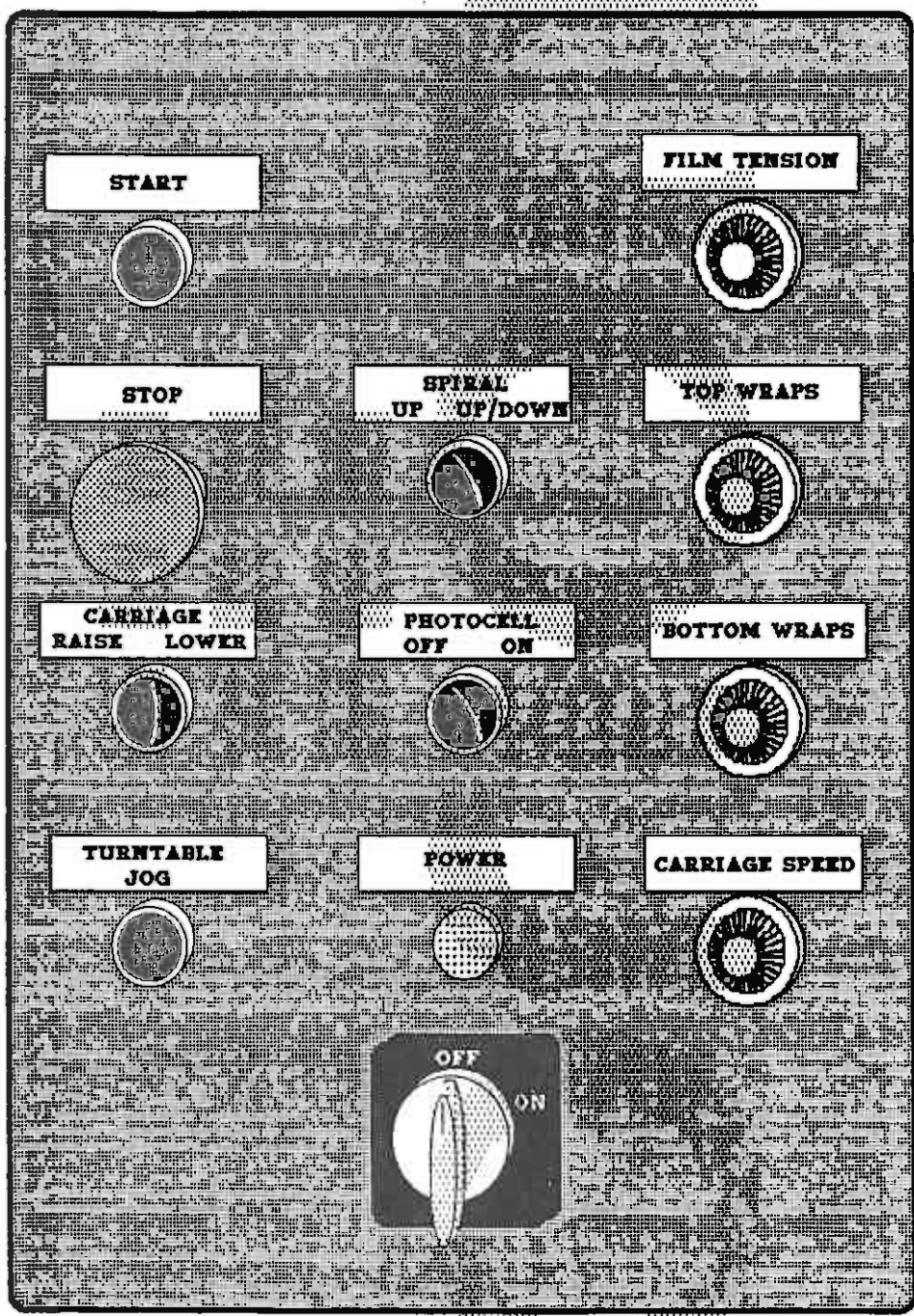

NEW. TWO POSITION CONTROL PANEL MOUNT

In order to facilitate access and manipulation, the Control Panel can be mounted in two positions:

- 1.-On the angle brackets aligned to the Tower.

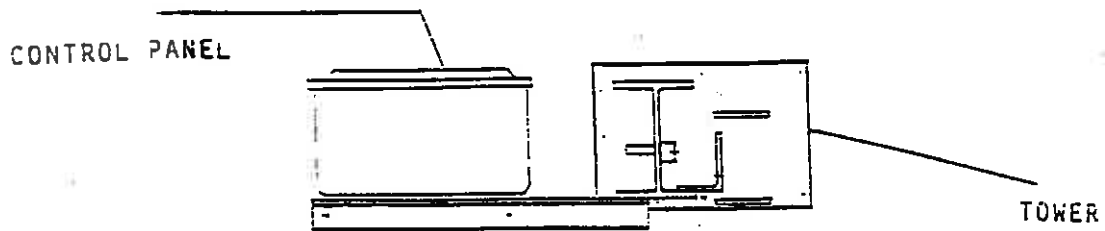

- 2.-With the position bar (installed between upper angles), Control Panel can be rotated forward/ to the side.
(additional screw attached to the tower's foot).

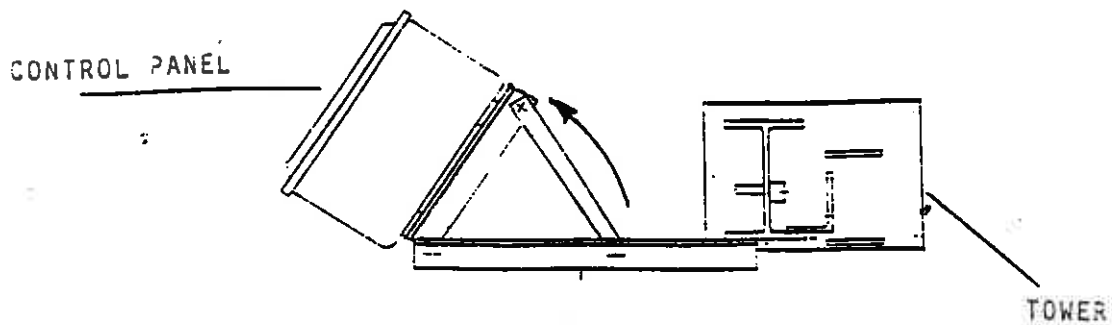

6.1 Power Switch

The Power Switch has two settings,

ON - Connects a 115 VAC power source to the machine,

OFF - Disconnects the power source.

Turning the power switch on causes the POWER light to turn on.

6.2 Start And Stop Switches

The Start switch is used to start the cycle once the load is on the turntable. At this point the cycle may be stopped at any time by pressing the Stop button.

NOTE: if the Stop button is pressed in the middle of the cycle, the carriage and turntable can be returned back to their home positions by using the jog buttons.

6.3 Spiral Wrap Switch

The Spiral Wrap switch has two positions,

UP - In the UP position the cycle will end after completing the specified number of top wraps, therefore, the machine will only wrap the load once, going up.

UP/DOWN - In the UP/DOWN position the cycle is complete after the load is wrapped in both the up and down directions.

6.4 Table Jog Switch

The table jog switch is a pushbutton switch that turns the turntable in a clockwise direction (as viewed from the top) when held depressed.

The turntable jog switch is inoperative during the wrap cycle.

6.5 Carriage Control Switch

The Carriage Control switch is a monostable three position switch with the following settings,

RAISE - Raises the carriage until the top limit switch on the tower is activated or until the photoswitch senses that the top of the load has been reached.

LOWER - Lowers the carriage until the bottom limit switch on the tower is activated.

The switch is normally in the middle position where the carriage remains stationary. Turning the switch to the RAISE or LOWER position will activate the carriage to move in its respective direction.

6.6 Photocell Switch

The Photocell switch has two settings,

ON - When turned ON, the photocell senses whether or not the carriage has reached the top of the load. The carriage will stop and begin the top wraps sequence once the top of the load is reached. The carriage will always stop at the top of the load regardless of its height. The photoswitch's position on the track can be adjusted in order to make the carriage pass the top of the load and overlap the top.

OFF - When turned OFF, the photocell is inoperative and the carriage will stop only once the top limit switch has been activated.

7.1 Film Tension

The film tension may be adjusted through the film tension control potentiometer. The pot has a range of tension from 0 to 10, 10 being the highest tension rating. This pot may be adjusted during the cycle.

CAUTION: Light loads may require lower tension settings than heavier loads.

The film tension is controlled through the dancer bar system. Occasionally the feedback potentiometer may need some adjustment. The adjustment of the feedback potentiometer can be performed while there is no film on the carriage. The bottom screw on the potentiometer coupling must first be loosened. Once the screw is loosened the potentiometer shaft must be turned until the prestretch motor just begins to hum but does not rotate, at which point the screw can be tightened. NOTE: the condition in which the motor hums but doesn't turn must be maintained even after the screw is tightened. If not, the adjustment procedure must be repeated.

7.2 Carriage Speed

There are two carriage speed controls on the panel,

CARRIAGE SPEED UP,

CARRIAGE SPEED DOWN.

The carriage speed controls can be used to control the amount of overlap the film will have on itself during a wrap. It is recommended to start with a RAPID upward wrap in order to stabilize the load early in the cycle.



The control potentiometers have settings from 0 to 10, the higher settings being the fastest. High settings will mean less film overlap because of faster carriage speed, and low settings will mean more film overlap because of lower carriage speeds.

7.3 Top And Bottom Wraps

There are two multi-position switches which control the number of wraps that may be put at the top and bottom of the load. Each switch is numbered from 0 to 10, but the effective range is only from 1 to 6, corresponding to the number of wraps which may be applied at the top or bottom of a load.

The top and bottom wrap switches may be set before the cycle begins.

7.4 Turntable Speed Adjustments

The turntable speed may be changed by adjusting the controls on the 750 or 850 board inside the panel. The controls on the board regulate the steady-state speed, the jog speed, and the acceleration and deceleration of the turntable. The controls are labeled on the board and listed below:

ZERO - The zero adjustment controls the deadband voltage for the turntable motor; it should be adjusted so that the motor just begins to hum but does not turn.

PRESET 1 - The preset 1 controls the wrapping speed of the turntable.

PRESET 2 - The preset 2 controls the jog speed of the turntable.

DN - The DN adjustment regulates the rate of deceleration of the turntable for when it reaches the end



of the cycle.

UF - The UF adjustment regulates the rate of acceleration of the turntable for the beginning of the cycle.

IRC - The IRC needs only adjustment if there is a very large range of load weight; for most applications it will not need to be adjusted but if adjustment is necessary, contact your Orion representative.

CL - The CL is factory set and needs no further adjustment.

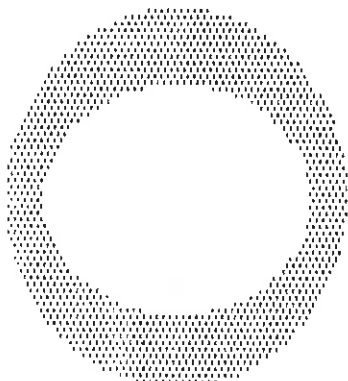
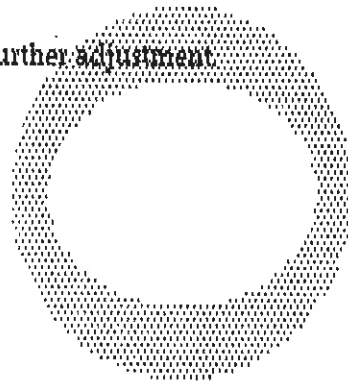
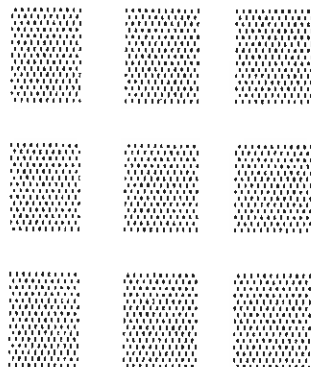



ment brushes should be installed before old brushes wear to 9/16" long, measured on the long side. After replacing brushes run the motor near rated speed for at least 1/2 hour with no load to seat the new brushes. Failure to properly seat the new brushes may cause commutator damage and rapid wear of the new brushes. If the commutator becomes rough, scored, or out of round, a competent motor shop should disassemble the motor and resurface the commutator. With every third brush change, have a competent motor shop resurface the commutator and blow the carbon dust out of the motor.

8.3 Chain Maintenance

To clean and relubricate chains, wipe them with an oily cloth every month. If the environment is very dusty or damp, it may be necessary to clean and relubricate the chains more often.

With time the chains will tend to stretch. A loose elevator chain should be tightened at the chain tensioner as shown on drawing number 200 192. A loose turntable drive chain should be tightened at the drive console as shown on drawing number 200 97.

8.4 Cam Follower Maintenance

The cam followers behind the carriage, on the tower, have deep grease pockets and do not need frequent relubrication.

The portion of the tower on which the cam followers roll should be cleaned and regreased every 300 hours of operation. If the machine operates in a dusty or corrosive environment the tower should be relubricated more often.

8.1 Speed Reducer Maintenance

On the reducing transmission, after the first week, all external cap screws and plugs should be checked for tightness. It is recommended to change the oil every six months or every 2500 hours of operation, whichever comes first. When adding oil the transmission should never be filled above the oil level mark indicated because leakage and overheating may occur. Below is a list of the type of lubricant that should be used.

Manufacturer	Lubricant
American Oil Co.	American Cyl. Oil No. 196-L
Cities Service Oil Co.	Citgo Cyl. Oil 180-5
Gulf Oil Corp.	Gulf Senate 155
Mobile Oil Corp.	Mobil 600 W Super Cyl. Oil
Phillips Oil Co.	Andes S 180
Texaco Inc.	624-650T Cyl. Oil
Shell Oil Co.	Valvata Oil 182
Union Oil Of Cal.	Red Line Worm Gear Lube 140

Reducing transmissions are found under the turntable, on the carriage, and at the base of the tower.

8.2 Motor Maintenance

An occasional inspection of the brushes should be made in order to establish a wear rate. Replace-

8.5 Caster Maintenance

The casters underneath the carriage must be relubricated every 200 hours of operation by injecting grease in the nipples and regreasing the surfaces of the casters. If the machine operates in a dusty or corrosive environment the tower should be regreased more often.

8.6 Ring Gear Maintenance

If the stretchwrapper has the optional ring gear turntable drive and support system, this maintenance routine must be performed.

The ring gear is located under the turntable and should be lubricated at fixed intervals. This should be carried out by injecting grease into all the lubrication nipples in succession until a collar of fresh grease appears around the perimeter of both sealing rings. The bearing should be rotated slowly during lubrication.

The relubrication interval depends on the operating conditions. For bearings exposed to an aggressive environment, relubrication should occur every 50 operating hours. Normally, relubrication should occur every 100 to 200 hours of operation. The gear teeth should also be relubricated. Lubricants of different manufacture recommended for the ring gear are shown below.

Manufacturer	Raceway Grease	Gearteeth Oil
BP	Energrease LS 2	Energol WRL
Castrol	Spheroil AP 2	Grippa 33 S
ESSO	Beacon 2	Surret Fluid 30
Gulf	Crown Grease No.2	Lubcote No.2
Mobil	Mobilux 2	Mobiltac E
SHELL	Alvania Grease R 2	Cardium Compound C/Fluid C



Texaco

Glissando FT 2

Crater 2 X Fluid

Valvoline

LB-2

FGC

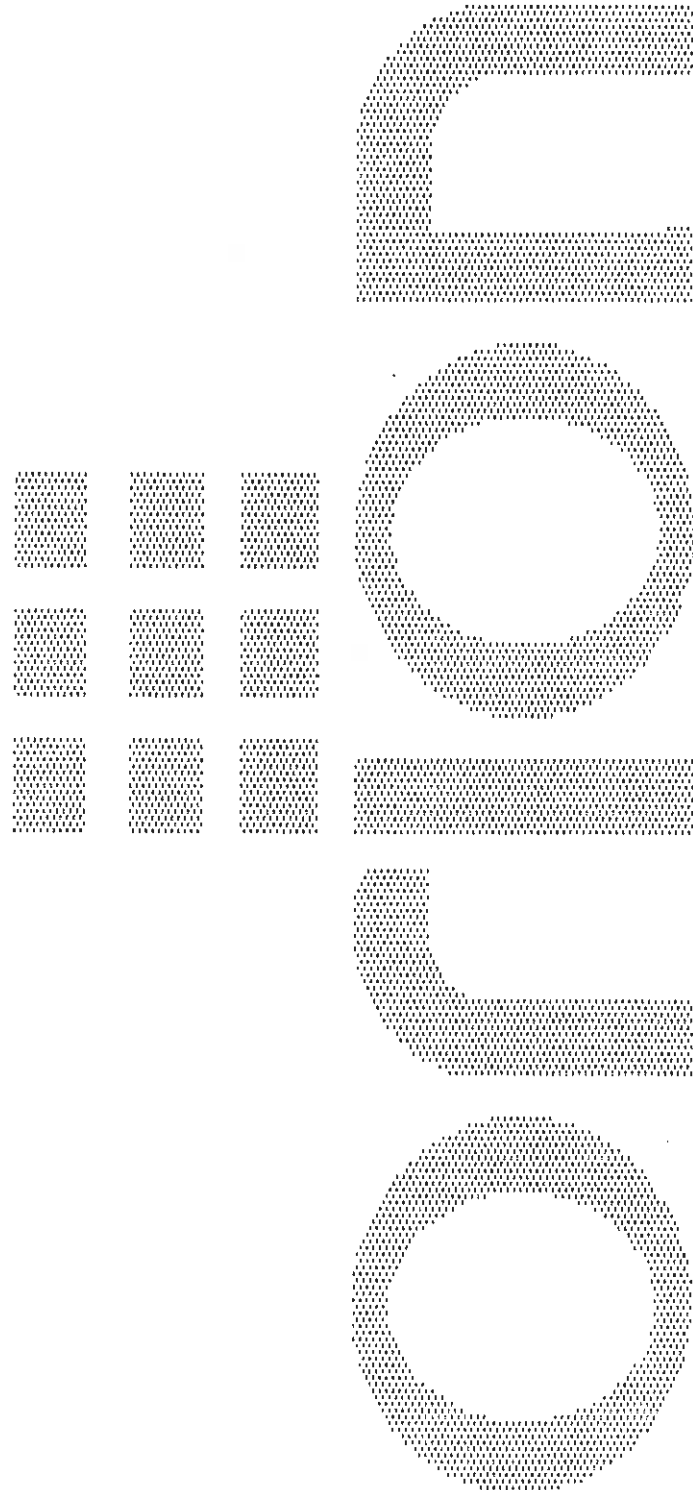

APPENDIX
C
O

ORION PACKAGING INC.

NOTICE

The manual covers standard features of the machine. Certain machine options may not be covered fully by this manual due to their unique application.

*FILM FEED PATTERN for the
STANDARD CARRIAGE*

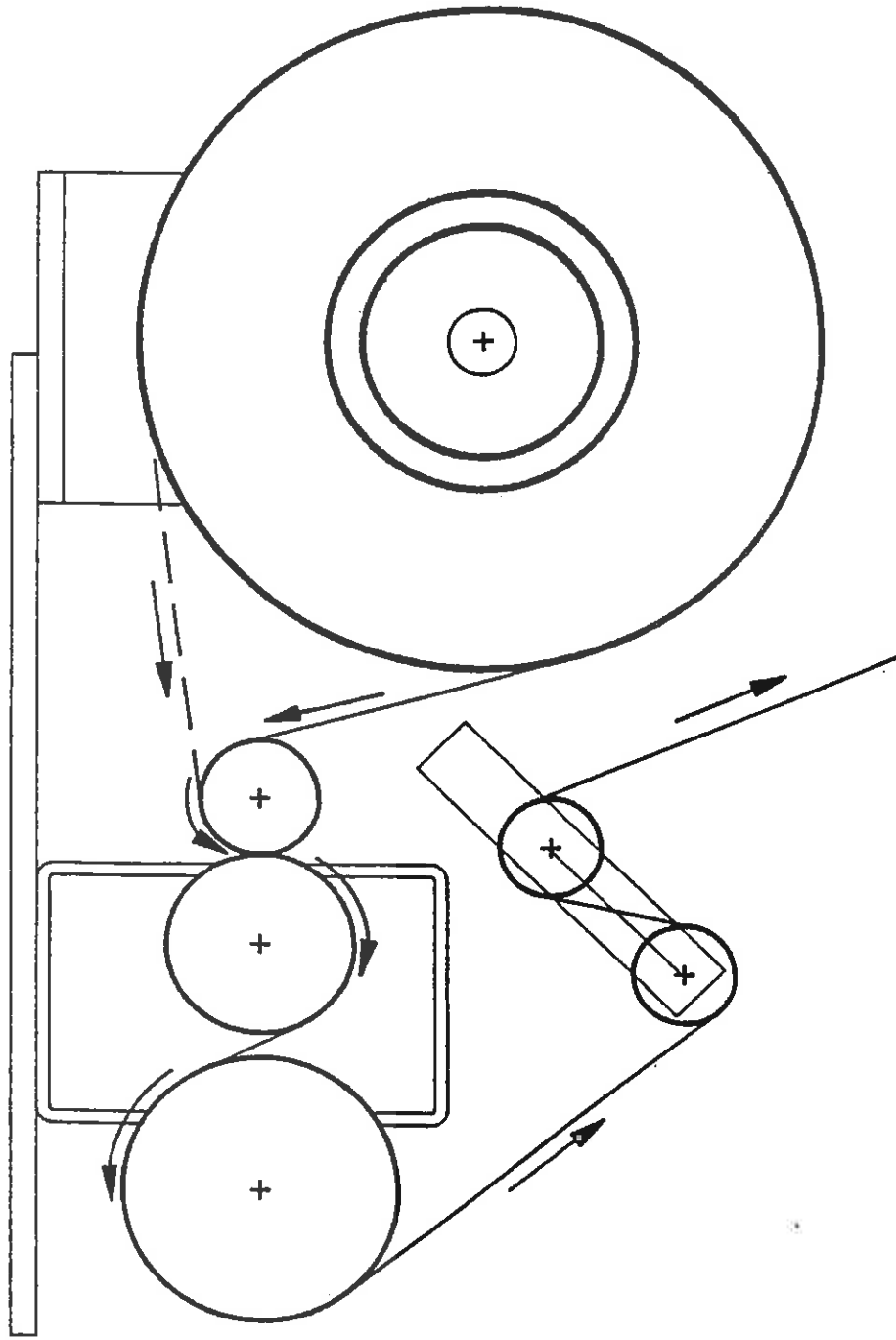

WARNING: DISCONNECT POWER BEFORE FEEDING FILM

Electrical Boards' Chart for ORION Stretchwrappers

	168-4	168-A	236	336	750+	750M-240y	850M	850C	155-3A
MLH 44 Processor	X		X		X				
MLH 44	X		X		X				X
MLH 55		X		X			X		X
MLH 66		X		X			X		X
MLH 77		X							X
PA 33	X			X	X				
FA 33	X			X		X		X	
MA 33	X			X		X		X	
MA 44	X			X	X			X	
MA 55	X			X			X	X	

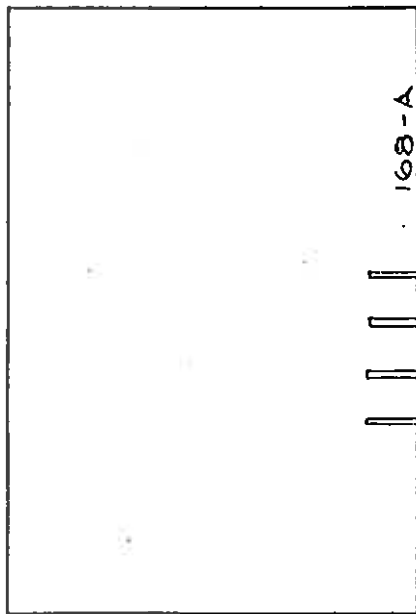

168-A

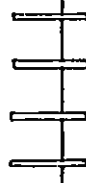

AC AC + -
120v DC

ORION PACKAGING INC		DESIGNER: VALENTINI
		DRAWN BY:
ECHELLE: N.T.S.	APPROUVE PAR:	REVISER PAR:
SCALE:	APPROVED BY:	REVISED BY:
DATE: 16-9-87		
168 - A		
NUMERO DE DESSIN DRAWING NUMBER		200 891 A

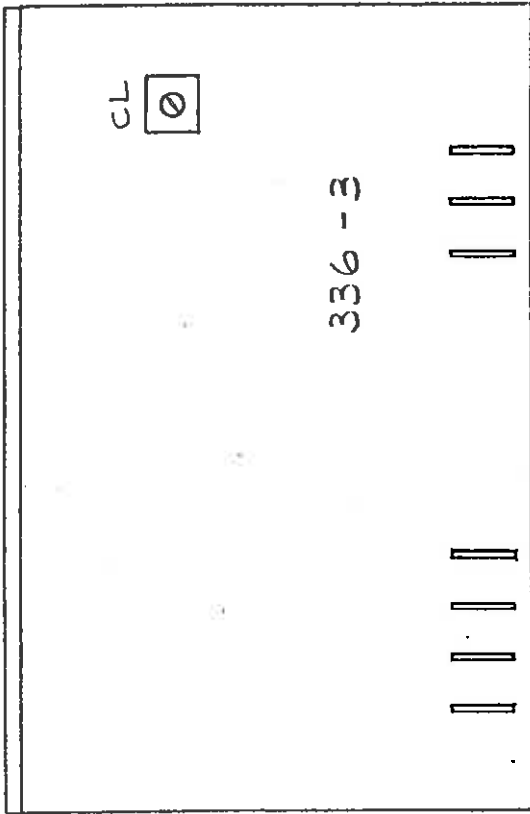

CL

0

336-3



CW W CCW

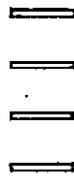

+ A A -
D C C D
C C

CL : CURRENT LIMITER

ORION PACKAGING INC.

ECHELLE: N.T.S.
SCALE:
DATE: 16-9-87

APPROUVE PAR:
APPROVED BY:
REVISE PAR:
REVISED BY:

336-3

336-3

NUMERO DE DESSIN
DRAWING NUMBER
200 890

DESSINE PAR: VALENTINI
DRAWN BY:
REVISE PAR:
REVISED BY:

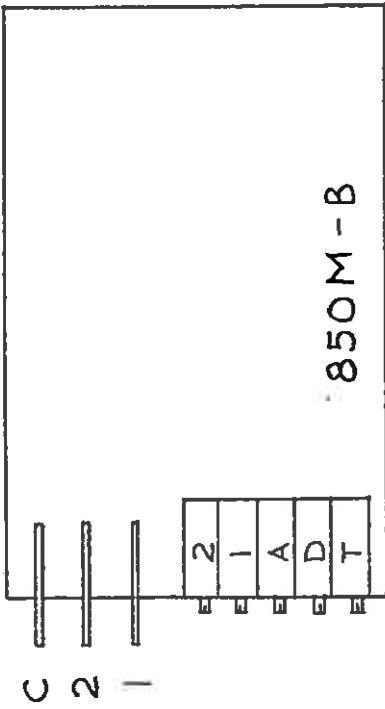
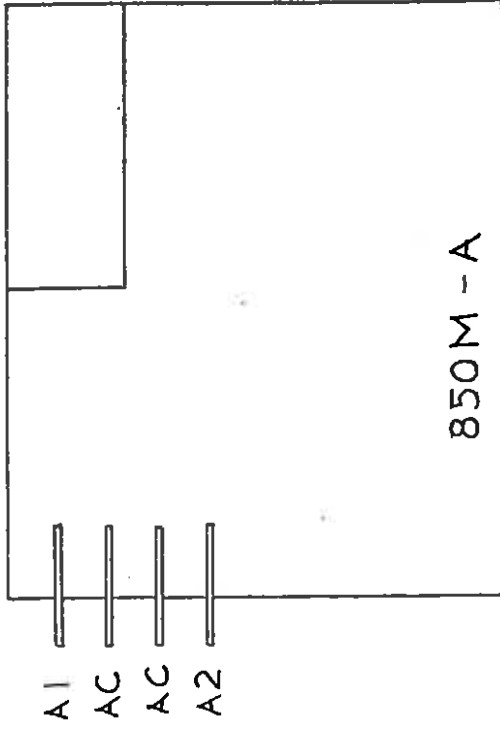

- 2: LOW SPEED ADJ.
- 1: HIGH SPEED ADJ.
- A: ACCELERATION ADJ.
- D: DECELERATION ADJ.
- T: CURRENT LIM.

ORION PACKAGING INC.

ÉCHELLE: N.T.S. APPROUVE PAR:
 SCALE: APPROVED BY:
 DATE: 16-9-87

DESSINÉ PAR: VALENTINI
 DRAWN BY:
 REVISE PAR:
 REVISED BY:

850 M

NUMERO DE DESSIN
 DRAWING NUMBER
 200 889

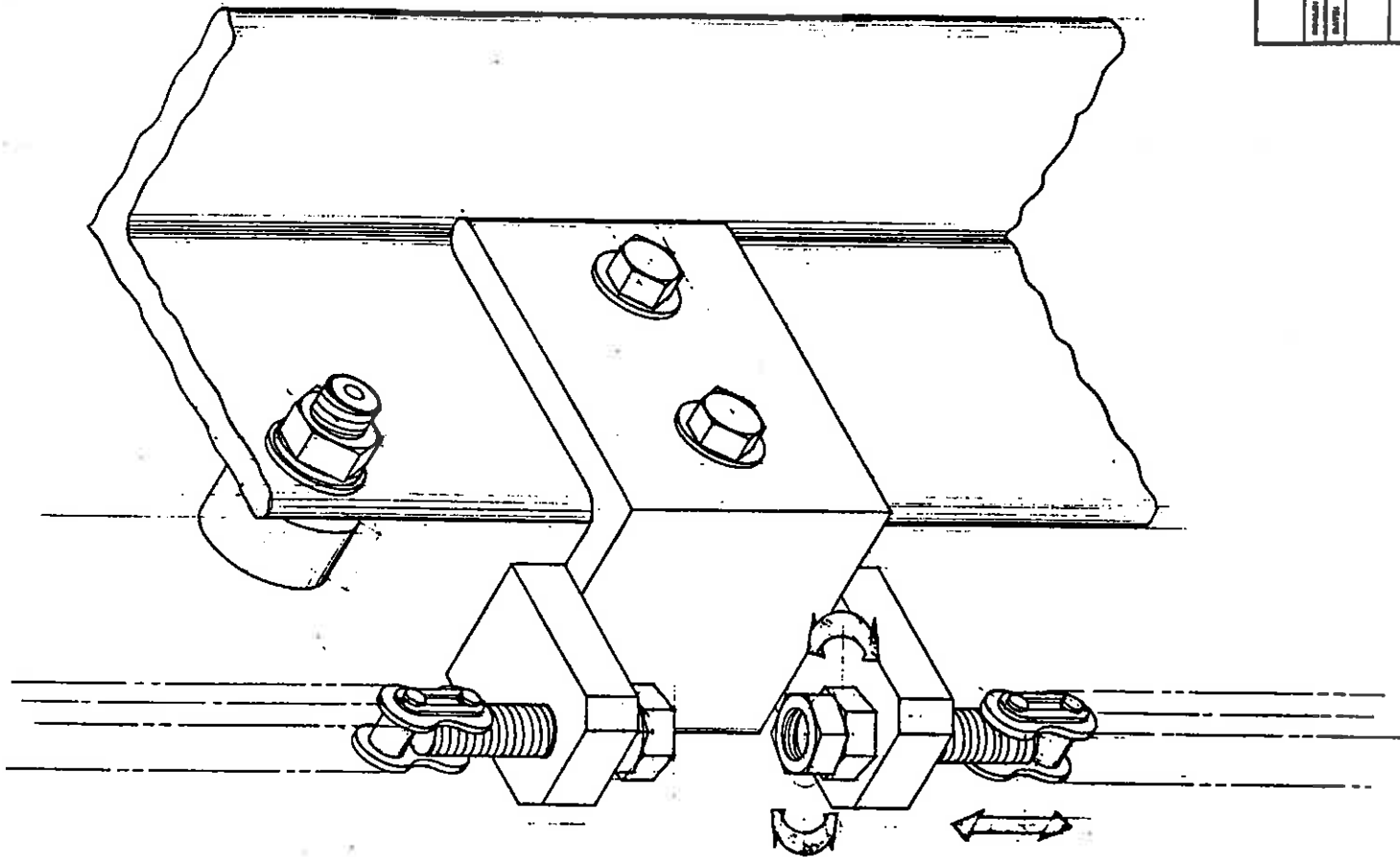

CHAIN TENSION
ADJUSTMENT

ORION PACKAGING		DESIGNED BY WAZA(PH)
REVISED N.I.S.	APPROVED BY:	
DATE: 10-7-86		
CHAIN TENSIONER ASS'Y		SCALE: AS SHOWN
		200 - 192

Motor dimensions

TEFC P/M motor

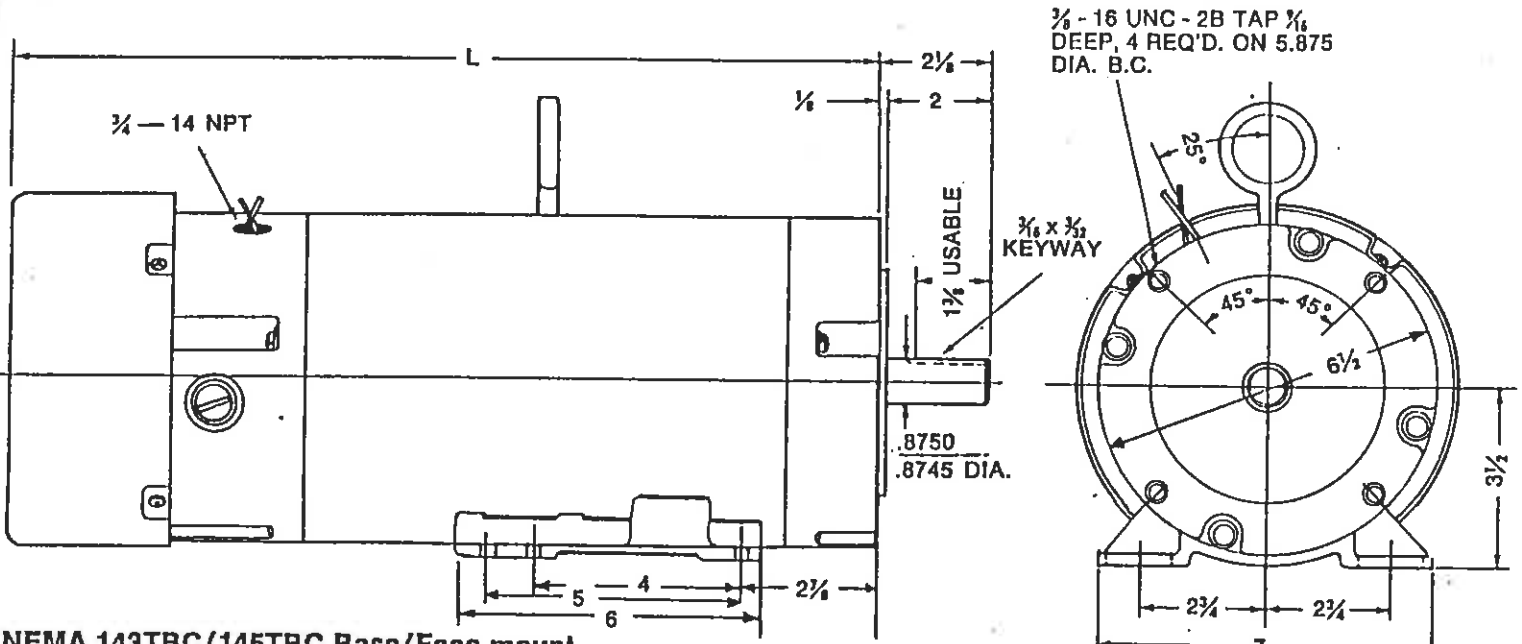

NEMA 143TBC/145TBC Base/Face mount

H.P.	RPM	VOLTS	AMPS	L	DUTY
1.5	1800	180	8.2	15 $\frac{1}{2}$	CONT.
2	1800	180	11.6	16 $\frac{1}{2}$	CONT.

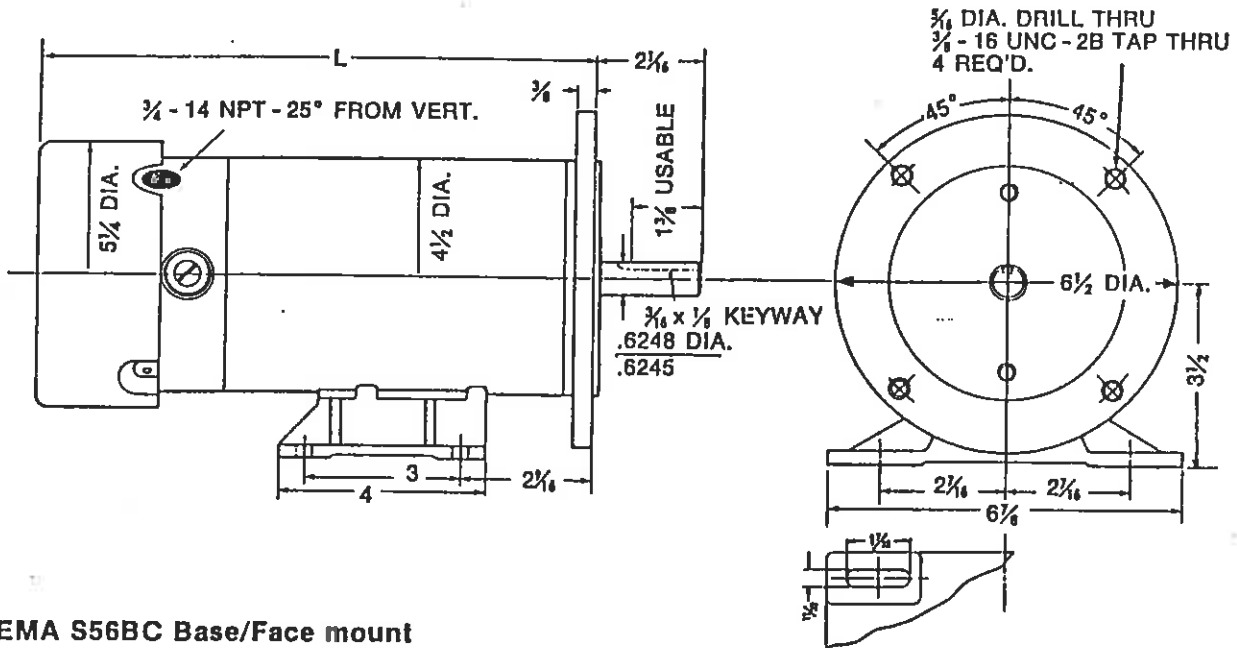

NEMA S56BC Base/Face mount

180 V.

H.P.	RPM	VOLTS	AMPS	L	DUTY
$\frac{1}{2}$	1725	180	2.8	10 $\frac{3}{4}$	CONT.
$\frac{3}{4}$	1725	180	3.5	12 $\frac{3}{4}$	CONT.
1	1725	180	5.35	14 $\frac{3}{4}$	CONT.

90 V.

H.P.	RPM	VOLTS	AMPS	L	DUTY
$\frac{1}{2}$	1725	90	5.35	10 $\frac{3}{4}$	CONT.
$\frac{3}{4}$	1725	90	8.1	12 $\frac{3}{4}$	CONT.
1	1725	90	10.6	14 $\frac{3}{4}$	CONT.

Lubrication

REDUCERS MAY BE FILLED TO THE PROPER LEVEL AT THE FACTORY WITH AGMA No. 8 compounded oil. AFTER INSTALLATION OF THE BREATHER PLUG, UNIT IS READY FOR USE. Before installing breather plug, refer to instruction tag and determine proper position according to reducer mounting.

We recommend an initial oil change after 250 hours of operation, then every six months or every 2500 hours of service under Class I Service. If fluctuating temperatures, humid, dirty or corrosive environment, oil changes should be made more frequently. Frequency can be established by oil sample analysis.

KEEP YOUR OIL CLEAN

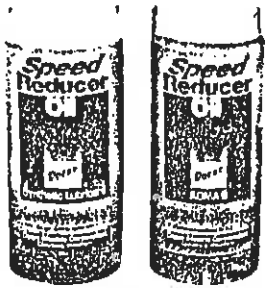

Doerr Electric replacement oil

To order oil, request:

Doerr part no. 00019001 — synthetic AGMA #7EP
(-40°F to 150°F)

Doerr part no. 00019101 — AGMA #8 (50°F to 125°F)

Oil is packed 12 one quart bottles per carton, minimum ship one carton.

Contact DEC Service Dept. for order information.

OIL CAPACITIES*

UNIT TYPE	UNIT SERIES				
	134	175	200	202	325
Worm Over	14	20	27	49	84
Worm Under	17	22	28	49	73
Vertical Output	10	15	20	37	63
"J" Mount	13	18	23	38	63

*Capacities in approximate ounces. On double reduction units determine capacity of both primary and secondary reducers.

OIL LEVELS*

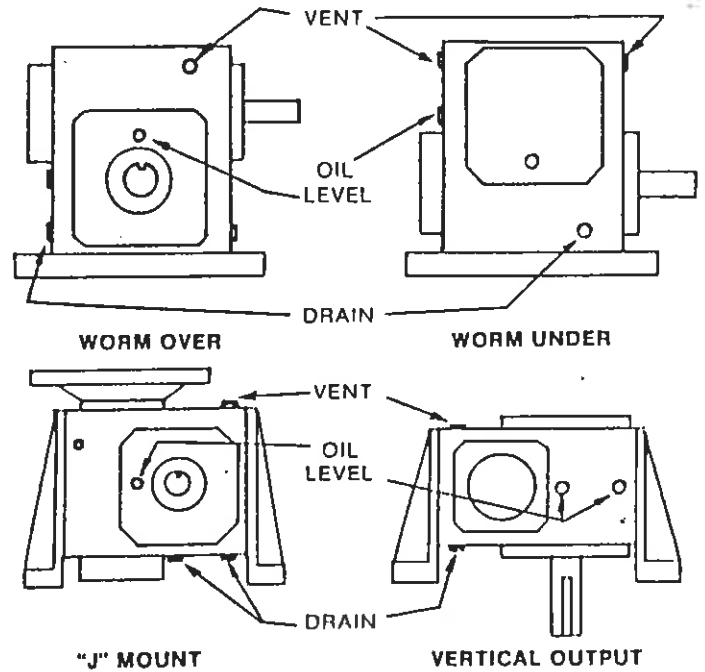

*On double reduction units fill and vent each unit to levels shown.



MAINTENANCE INSTRUCTIONS

STANDARD REDUCERS SERIES 133, 175, 206, 262, 325

INDEX

	Page
Introduction	1
Equipment Required	1
General Instructions	1
Housings	1
Seals	1
To Change Output Shaft Direction	1
Unit Disassembly, Parts Service, and Reassembly	1
Disassembly	1
Low Speed Shaft Removal	1
High Speed Shaft Removal	1, 2
Parts Service	2
Housing	2
Seal Cages and End Cover	2
Air Vent	2
Seals	2, 3
Bearings	3
Worm Gear and Shaft	3
Unit Reassembly	4
High Speed Shaft Assembly	4
Low Speed Shaft Assembly	4
Preventive Maintenance	6
Stored and Inactive Units	6
Parts Ordering Instructions	6
Exploded Views	7, 8, 9
Parts List	9
Warranty	Back Cover

MAINTENANCE INSTRUCTIONS FOR STANDARD REDUCERS

Series 133, 175, 206, 262 and 325

INTRODUCTION

The following instructions apply to standard Worm Gear Reducers. When ordering parts or requesting information specify all information stamped on the reducer nameplate. The nameplate will also identify the type of lubricant to be used.

EQUIPMENT REQUIRED

In addition to standard mechanic's tools, the following equipment is required: arbor press, wheel puller, torque wrench, dial indicator, seal driver, bluing, Permatex No. 2 and Permatex No. 3, snap ring pliers for internal and external rings.

GENERAL INSTRUCTIONS

Housings — Clean external surfaces of reducer before removing seal cages and end covers to prevent dirt from falling into the unit. Record mounting dimensions of accessories for reference when reassembling. If it is necessary to remove the reducer from its operating area, disconnect all connected equipment and lift reducer from its foundation.

Seals — Replacement of all seals is recommended when a unit is disassembled. However, if seals are not to be replaced, protect seal life by wrapping shaft with thin, strong paper coated with oil or grease before removing or replacing seal case assembly. Clean the shaft but do not use any abrasive material on the shaft surface polished by the seal.

CAUTION

If the reducer is painted, extreme care should be taken to mask the shaft extensions and rubber surface of the seals. Paint on the shaft adjacent to the seal or on the seal lip will cause oil leakage.

TO CHANGE OUTPUT SHAFT DIRECTION

To change the hand of a unit from left hand to right hand, or vice versa, the following instructions apply:

1. Remove drain plug and drain oil from unit.
2. Remove end cover and seal cage cap screws; then while supporting output shaft remove end cover and shims from the unit.
3. Remove output shaft and seal cage together from extension side.

NOTE: Keep shims with their respective seal cage and end cover.

4. Insert seal cage, shims and sub-assembly into the housing from the side opposite from which they were removed. Insert seal cage cap screws and tighten with light pressure.
5. Assemble end cover and shims. Insert end cover cap screws and tighten with light pressure.
6. Turn high speed shaft in both directions to see that gear train is running freely.
7. Cross tighten seal cage and end cover cap screws to torques listed in Table 1.

TABLE 1. CAPSCREW TIGHTENING TORQUE

Capscrew Diameter	1/4 - 20 UNC	5/16 - 18 UNC	3/8 - 16 UNC
Torque (in. lbs.) Dry	96	204	360

UNIT DISASSEMBLY, PARTS SERVICE, AND ASSEMBLY

Disassembly:

1. Remove drain plug and drain oil from unit.
2. Low speed shaft (gear shaft) removal:
 - A. Remove end cover and seal cage cap screws.
 - B. With a firm hold on the output extension remove end cover and shims.
 - C. Carefully slide output shaft assembly and seal cage out extension side.
 - D. Slide seal cage off low speed shaft using caution to prevent damage to seal lips.
 - E. Wire or tie the shims to their mating end cover and seal cages. They will be available for reference when assembling the unit.
3. High speed shaft (worm shaft) removal:
 - A. Position unit with input shaft down. With a small chisel make a groove in the stamped steel cover opposite the shaft extension. Pry cover off.

- B. Remove internal snap ring from housing bore.
- C. Reposition the housing with the worm shaft horizontal. Using a plastic hammer gently tap on the end of the shaft extension to feed worm shaft assembly through housing and out.

Parts Service:

- 1. **Housing** — Clean inside of housing with kerosene or solvent and then dry.
- 2. **Seal cages and end cover** — Remove dirt from joint faces, wipe clean and dry.
- 3. **Air vent** — Wash in kerosene, blow clean and dry.
- 4. **Seals** — To replace seals without dismantling reducer refer to steps C through F below. To replace seals when the entire reducer is dismantled and coupling hubs, sprockets, pulleys, pinions, keys, etc. have been removed the following instructions apply:

NOTE: Replacement of all seals is recommended when a unit is disassembled.

Caution

New seals will leak if the seal lips or if seal's rubbing surface on the shaft has been altered. Protect seal lips at all times. Clean the shaft but do not use any abrasive material on the shaft surface polished by the seal.

- A. Block up seal cages and press or drive out seal.
- B. Remove old sealing compound from seal seat in cage if it is present. If a seal with rubber coating on the outside diameter is used, no Permatex is necessary. If no rubber coating is on seal outside diameter, coat seal cage bore with Permatex No. 3 or equivalent immediately before assembly. To prevent possible damage to seal lips, do not reassemble seals until high speed and low speed shafts have been reassembled to the housing. Then see steps E and F below.
- C. See Figures 1 through 4—To replace seals without dismantling reducer, proceed as follows:

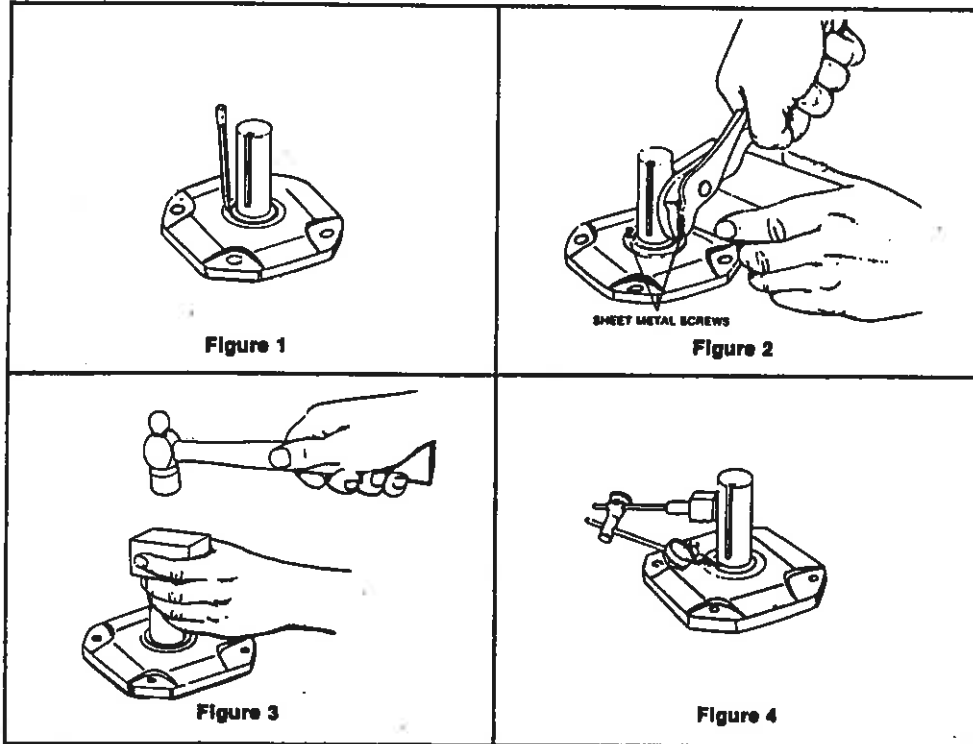

Caution

Do not damage shaft; new seals will leak if seal contacting surface is marred. Use punch and place two or more holes in steel casing of seal, Figure 1. (The steel casing may be rubber coated) Insert sheet metal screws, leaving the heads sufficiently exposed so they can be pried up or grasped with pliers, Figure 2. Do not drill holes because chips may get into the unit.

- D. Work seal loose. Be careful to keep all metal or dirt particles from entering unit. Remove old sealing compound from seal seat if it is present. Also remove burrs and sharp edges from shaft. Clean with rag moistened with solvent. Do not use abrasive material on shaft seal contacting surface.

Caution

- E. Protect seal lips when handling; seal leakage will result if these are damaged. If a seal with rubber coating on the outside diameter (O.D.) is used, no Permatex is necessary. If no rubber coating is on seal O.D., coat seal cage bore with Permatex No. 3 or equivalent. Coat seal lips with oil and carefully work seal into position. Before sliding seal into position, protect seal lips from shaft keyway edges by wrapping shaft with thin, strong paper coated with oil. Position garter spring toward the inside of the unit. Place a square faced pipe or tube against the seal O.D. and drive or press seal until fully seated as shown in Figure 3. Do not strike seal directly.

- F. For best performance, seat the seal square with shaft within .005" at 180°. Check with dial indicator as shown in Figure 4, Page 2, or with a straight edge and feelers, or square and feelers. To straighten a cocked seal, place tubing over the seal and tap the tube lightly at a point diametrically opposite the low point on the seal. DO NOT strike seal directly.

5. Bearings —

- A. Wash all bearings in clean kerosene and then dry.
B. Inspect bearings carefully and replace those that are worn or questionable.
NOTE: Replacement of all bearings is recommended.
C. Use a wheel puller or press to remove worm shaft bearings. Apply force to inner race only — not to cage or outer race.
D. Use a wheel puller or press to remove output bearing inner races.
E. New seal cages and end covers must be used when replacing output bearings. Output bearing outer races must be pressed in square and seated completely.
F. To replace output bearing inner races and all input bearings, heat bearings in an oil bath or oven to maximum of 290 degrees F (143 degrees C). Slide high speed shaft bearings onto the oiled shaft until seated against the shoulder or snap ring of the shaft. Slide low speed shaft bearings onto the oiled shaft against the gear spacer.
G. Thoroughly coat all bearings with lubricating oil.

6. Worm, gear and shafts

- A. Worm and high speed shaft—since all worms are integral with the high speed shaft, any wear or damage to the worm will necessitate replacing both.
B. Press shaft out of bronze worm gear. To reassemble gear and low speed shaft, freeze shaft or heat gear. Do not exceed 200 degrees F (93 degrees C). Insert key into shaft keyway and press shaft into oiled gear bore. The short hub of the gear must be assembled toward snap ring on the shaft.
NOTE: It is advisable to replace both the worm and worm gear should either of the assemblies require replacement.

Unit Reassembly:

1. Preliminary

- A. Check to see that all worn parts have been replaced, gear and bearings coated with oil and all parts cleaned. Remove all foreign matter from unit feet. The feet must be flat and square with each other.
- B. Before starting to reassemble reducer, add old shims or replace with new shims of equal thickness.

2. High Speed Shaft (Worm Shaft) Assembly

- A. Lubricate bearing bores of housing and insert high speed shaft sub-assembly from opposite extension end into housing until seated against shoulder in bore. Tap the end of the shaft lightly with a plastic hammer to feed bearings through bores.
- B. Lock high speed sub-assembly in housing bore with lock ring.
- C. Coat outside diameter of stamped steel end cover with Permatex No. 2 and press into high speed bore opposite extension end until flush with housing. If steel endcover is rubber coated then no Permatex is necessary.

3. Low Speed Shaft (Gear Shaft) Assembly

- A. Determine output shaft direction.
- B. Assemble low speed shaft assembly, seal cage, and end cover with shims on both seal cage and end cover. Torque cap screws to torques listed in Table 1. Rotate the input shaft to seat output bearings.
- C. Moving the shaft back and forth by hand, check axial float with dial indicator as shown in Figure 5. Axial float must be .0005-.003 with .0005 being the absolute minimum. Do not preload bearings. If the axial float is not as specified add or subtract required shims under end cover.

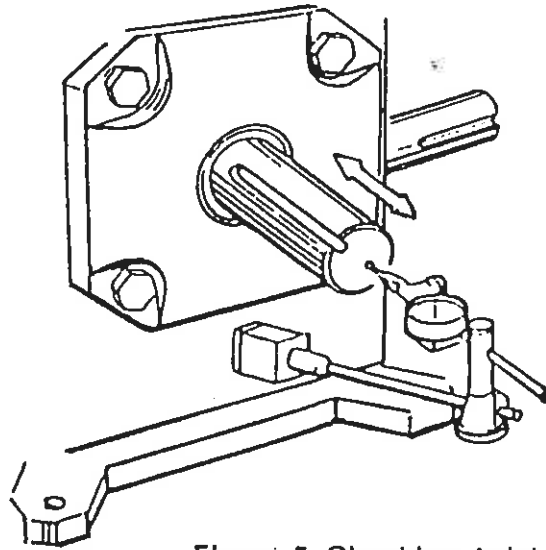

Figure 5 Checking Axial Float

- D. Remove output shaft with seal cage and apply bluing to entire worm thread. Worm thread must be clean of oil. Reassemble output shaft and seal cage with output key facing up.
- E. Use a rag to apply hand pressure to the output shaft and rotate the high speed shaft until output key is down. Return output shaft to original position by reversing rotation. Remove output shaft and seal cage to inspect contact. Compare with Figure 6. If contact is not correct move assembly in the direction shown in Figure 6 by adding shims to the side to which the arrow points after removing them from the opposite side. Repeat steps D and E until contact pattern is correct.
- F. Recheck axial float with dial indicator.
- G. When contact pattern is correct tighten seal cage and end cover cap screws to torques listed in Table 1 page 1.

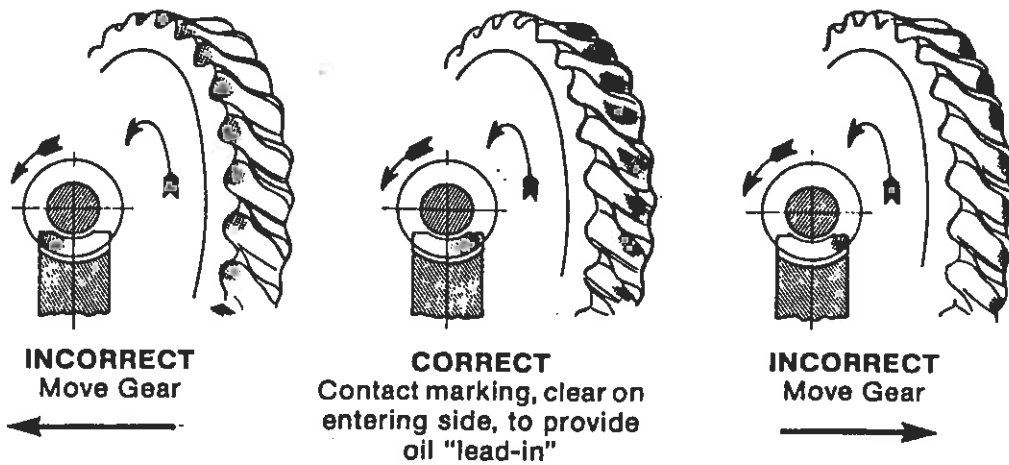

Figure 6 Gear Contact Pattern

4. **Seals** — To reassemble seals to unit, see Parts Service Steps 4E and 4F, page 3.
5. **Motorized Coupling Adaptor**
 Certain mounting dimensions should be adhered to when removing motor and coupling assembly for service. When ordering replacement coupling halves (metal gear), specify correct bore diameter. See Table 2 for mounting dimensions and available bore sizes.

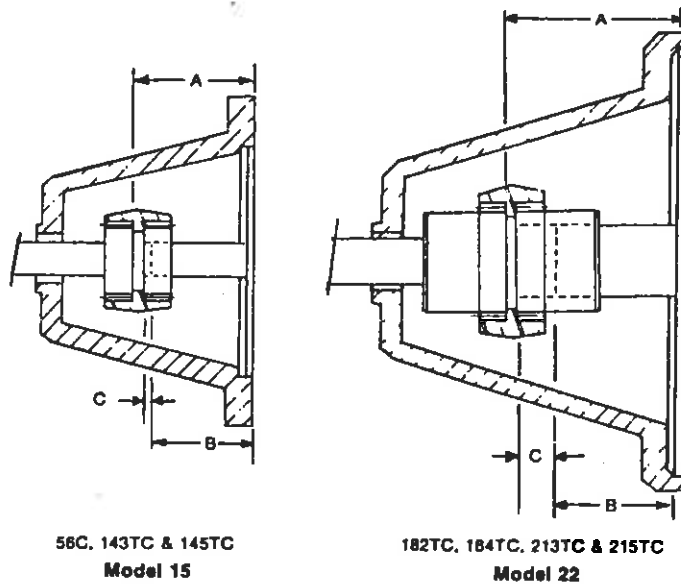

Figure 7 Motorized Coupling Adaptor

TABLE 2. COUPLING ADAPTOR DATA

"C" COUPLING MOUNTING DATA

N.E.M.A. Frame No.	Mounting Dimensions		
	Reducer A ± 1/64	Motor B ± 1/64	C
56C	2 5/16	2 1/8	1/16
143TC	2 5/16	2 1/8	—
145TC	2 5/16	2 1/8	—
182TC	3 5/16	2 5/8	1/2
184TC	3 5/16	2 5/8	1/2
213TC	3 5/16	3 1/8	—
215TC	3 5/16	3 1/8	—

BORE SIZES AVAILABLE

MODEL 15		MODEL 22	
Bore	Kwy.	Bore	Kwy.
.500	None	—	—
.500	1/8 x 1/16	—	—
.625	3/16 x 3/32	.625	3/16 x 3/32
.750	3/16 x 3/32	.750	3/16 x 3/32
.875	3/16 x 3/32	.875	3/16 x 3/32
—	—	1.125	1/4 x 1/8
—	—	1.375	5/16 x 5/32

6. Final Inspection

- A. Turn gear train over by hand as a final check.
- B. Re-install reducer and accessories.

CAUTION: Discard motor key. Use only special key provided with reducer. Failure to use special key will make assembly impossible.

- C. Fill reducer with the recommended oil to proper level. See Fig. 8 for standard oil levels. (Type of oil recommended — see nameplate).
- D. Spin test for three minutes and check for noise, leakage, and rapid temperature rise.

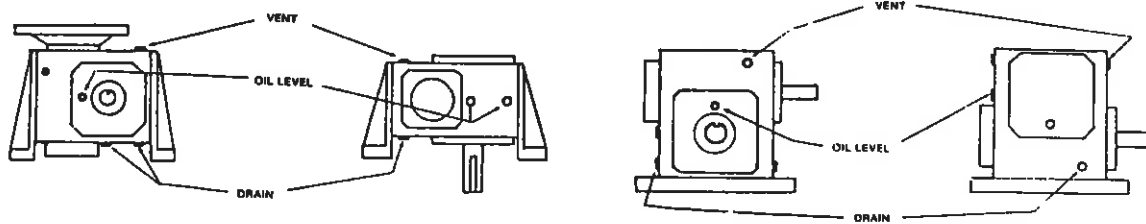

Figure 8 Standard Oil Levels

PREVENTATIVE MAINTENANCE

- A. After first week check all external cap screws and plugs for tightness.
- B. Periodically, check oil level when gears are at rest. Add oil if needed. Do not fill above mark indicated by level because leakage and overheating may occur.
- C. Oil changes — For normal operating conditions, change oil every six months or 2500 hours, whichever occurs first. Also if the unit is operated in an area where temperatures vary with the season, change the oil viscosity to suit the temperature. Most lubricant suppliers can test oil periodically and recommend economical oil change schedules.

CAUTION

See nameplate for type of lubricant to be used.

STORED AND INACTIVE UNITS

1. Each unit is shipped with oil that will protect parts against rust for a period of 4 months in an outdoor shelter or 12 months in a dry building after shipment from the factory. Indoor dry storage is recommended.
2. If a unit is to be stored or is to be inactive after installation beyond the above periods, fill the unit completely with oil.

CAUTION

Before starting a stored unit or re-starting an inactive unit, the oil level should be returned to the proper value as indicated by the oil level.

PARTS ORDERING INSTRUCTIONS

When ordering replacement parts first locate the exploded view that corresponds to your Doerr Electric gear reducer. Then determine which parts must be ordered. To order the parts, please provide the following:

1. Complete Model Number (Nameplate)
2. Item Number (Exploded view and parts list)
3. Part Description (Parts list)

Note that one parts list covers all five exploded views. Although a single item number may refer to the same part on all five exploded views, it is incorrect to assume that these parts are interchangeable. They are not. Therefore, it is imperative that items 1 through 3 above be provided when ordering your parts.

Failure to provide this information will only slow or prevent the processing of your order.

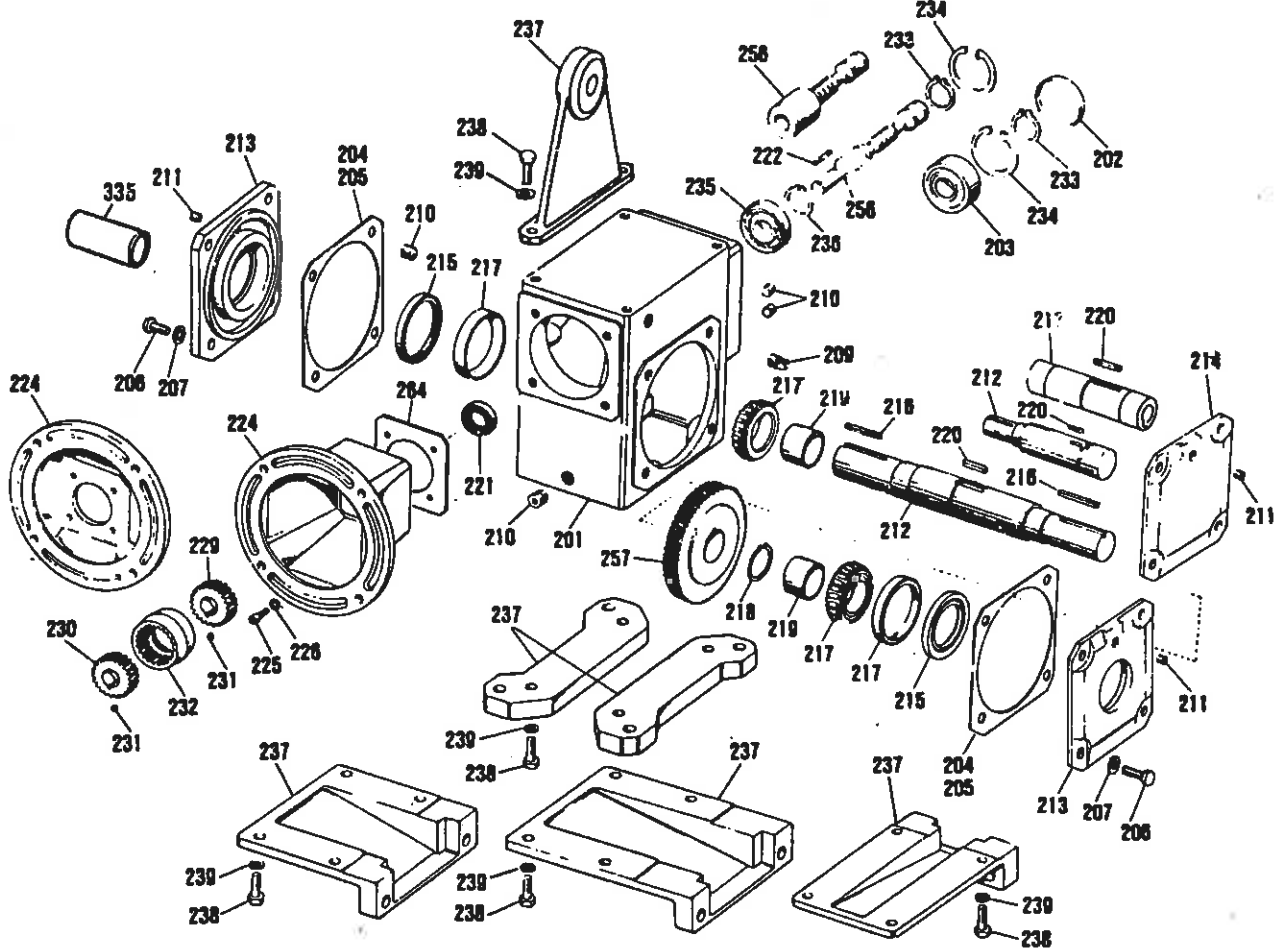

Single Reduction Unit 133, 175, 206 Series

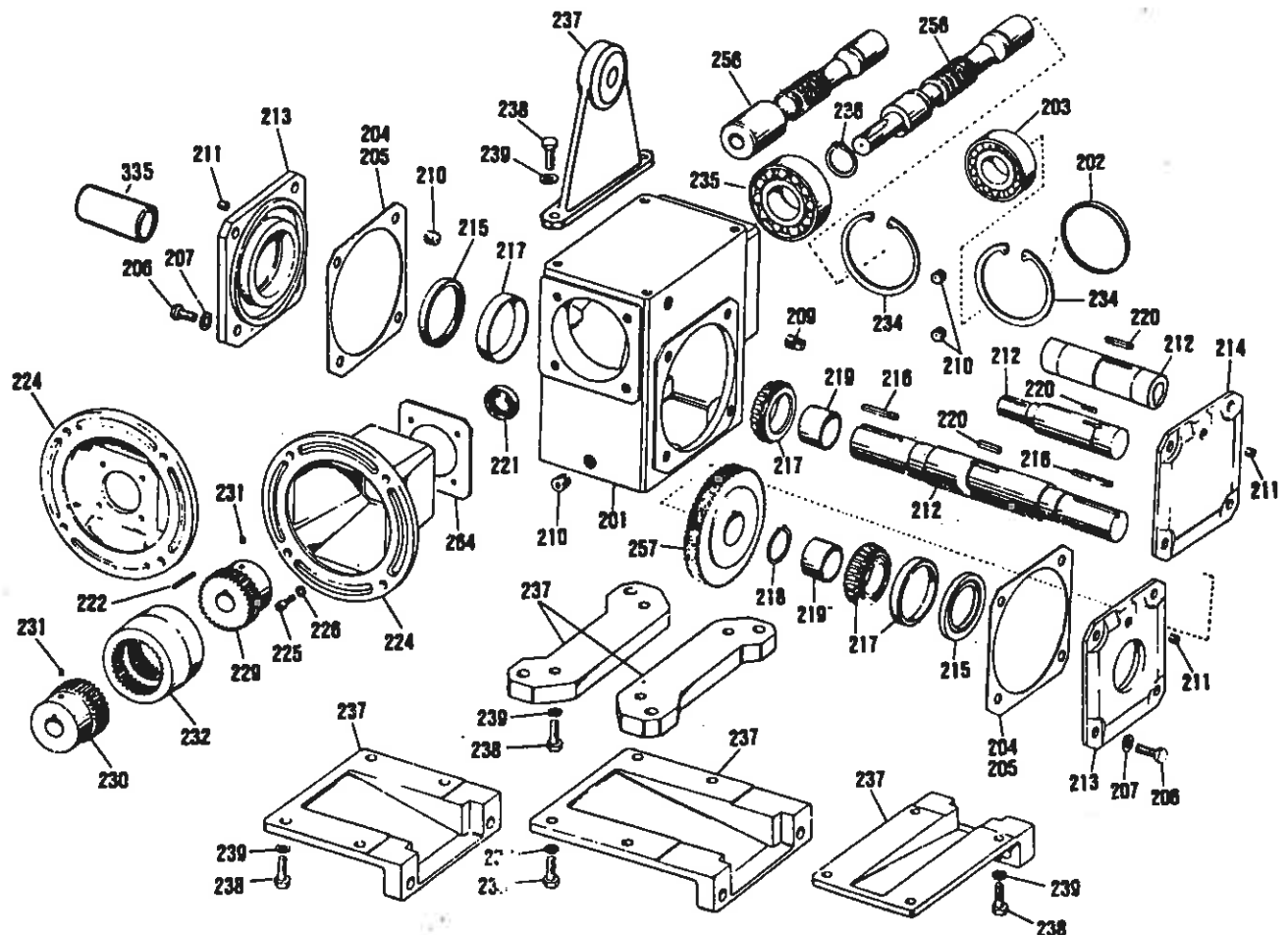

Single Reduction Unit 262, 325 Series

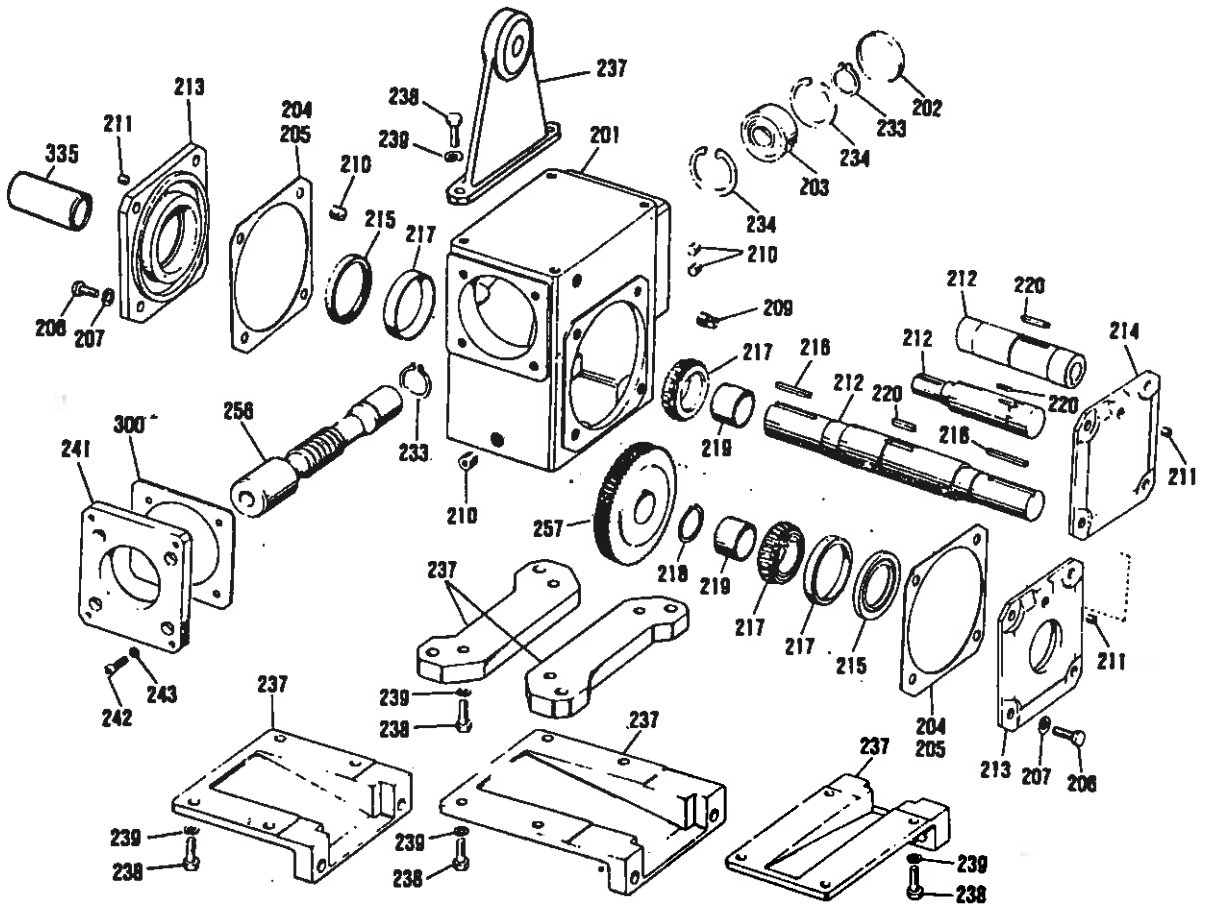

Double Reduction Secondary Unit 133, 175, 206 Series

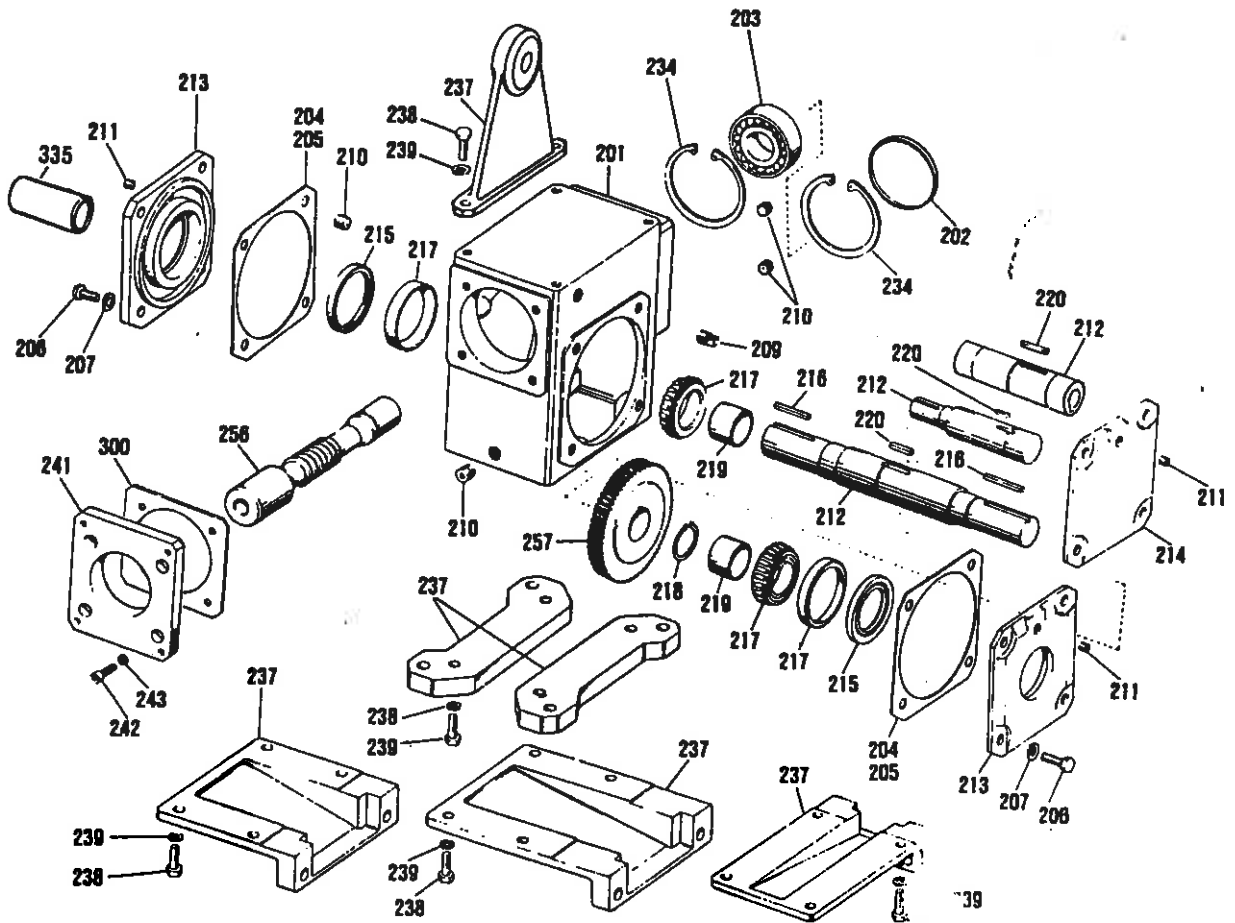

Double Reduction Secondary Unit 262, 325 Series

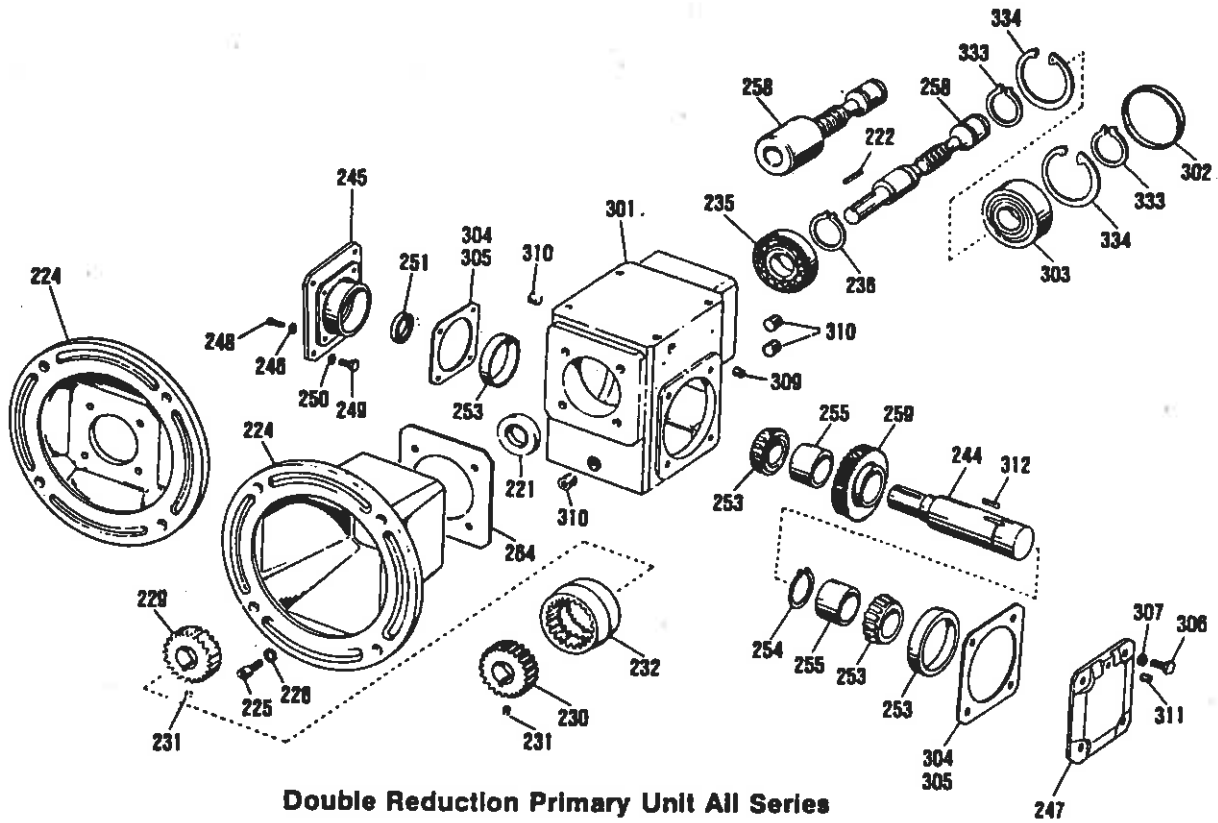

Double Reduction Primary Unit All Series

PARTS LIST
(Applies to all exploded views)

ITEM	DESCRIPTION	ITEM	DESCRIPTION	ITEM	DESCRIPTION
201	Housing	229	Coupling Hub (Unit)	255	Spacer
202	End Cover	230	Coupling Hub (Motor)	256	Worm
203	Bearing	231	Setscrew	257	Gear
204	Shim (.019 Thick)	232	Coupling Sleeve	258	Worm
205	Shim (.007 Thick)	233	Lock Ring	259	Gear
206	Capscrew	234	Lock Ring	260	Thrust Plate
207	Lock Washer	235	Bearing	261	Capscrew
209	Vent Plug	236	Lock Ring	264	Gasket
210	Pipe Plug	237	Base	300	Gasket
211	Pipe Plug	238	Capscrew	301	Housing
212	Output Shaft	239	Lock Washer	302	End Cover
213	Seal Cage	241	Secondary Adaptor	303	Bearing
214	End Cover	242	Capscrew	304	Shim (.019 Thick)
215	Oil Seal	243	Lock Washer	305	Shim (.007 Thick)
216	Key	244	Primary Output Shaft	306	Capscrew
217	Bearing	245	Primary Adaptor	307	Lock Washer
218	Lock Ring	246	Lock Washer	309	Vent Plug
219	Spacer	247	End Cover	310	Pipe Plug
220	Key	248	Capscrew	311	Pipe Plug
221	Oil Seal	249	Capscrew	312	Key
222	Key	250	Lock Washer	333	Lock Ring
224	Motor Flange	251	Oil Seal	334	Lock Ring
225	Capscrew	253	Bearing	335	Shaft Cover
226	Lock Washer	254	Lock Ring		

Note: When ordering replacement parts, specify model number, item number, and part description.