



ATTENTION:

VERY IMPORTANT

Before unpacking and the stretch wrapper and conveyors read section 5 of this manual for unpacking and inspection instructions.

Failure to do so can result in forfeiture of the warranty.



fa33

FULLY AUTOMATIC
STRETCHWRAPPER
OWNER'S MANUAL

ORION PACKAGING INC.
4263 Richelieu
Montreal H4C 1A1
Tel.: 514-937-6642

TABLE OF CONTENTS

TITLE	PAGE
1. FA 33 SPECIFICATIONS	1
2. STANDARD FEATURES	3
3. OPTIONS	4
4. PARTS LISTS	
4.1 Tower Parts list	5
4.2 Carriage Parts List	7
4.3 Sealing Mechanism Parts List	10
4.4 Base And Turntable Parts List	14
4.5 Conveyor Parts List	16
5. MACHINE INSPECTION AND INSTALLATION	
5.1 Inspection Upon Arrival	18
5.2 Machine Installation	19
6. MANUAL CONTROLS	20
6.1 Power Switches	21
6.2 Operation Mode Selector Switch	21
6.3 Conveyor Control Switches	22
6.4 Carriage Control Switches	22
6.5 Turntable Jog Switch	23
6.6 Clamp Jog	23
6.7 Rewrap Selector	24
7. CYCLE ADJUSTMENT CONTROLS	
7.1 Film Tension	25



7.2 Carriage Speed	25
7.3 Top And Bottom Wraps	26
7.4 Turntable speed adjustments	26
8. MACHINE MONITORING SWITCHES	
8.1 Photoswitches	28
8.2 Limit Switches	29
8.3 Proximity Switch	29
8.4 Knife Thermostat	30
8.5 Broken Film Sensor	30
9. MACHINE MAINTENANCE	
9.1 Speed Reducer Maintenance	31
9.2 Ring Gear Maintenance	32
9.3 Motor Maintenance	32
9.4 Chain Maintenance	33
9.5 Cam Follower Maintenance	33
9.6 Pneumatic System Maintenance	33
APPENDIX	34

1. FA 33 SPECIFICATIONS

Power requirements: 230 VAC, 60 Hz, 30 A, 1 phase

Air pressure requirements: 3 cfm at 80 psi min.

Machine floor space requirements: see drawing number 200 607

Distance from floor to top of table conveyor: 19 3/4 inches

Turntable dimensions: 76 inches

Turntable drive motor: 1 1/2 hp, 1750 rpm, 180 VDC, TEFC

Table conveyor motor: 1/2 hp, 1750 rpm, 90 VDC, TEFC

Conveyor units' motors: 1/2 hp, 1750 rpm, 90 VDC, TEFC

Conveyor speed: 30 fpm

Conveyor rollers: 3 1/2 inch diameter at 4 1/2 inch centers; loop to loop chain drives; rollers are shafts welded through tubes with pillow block bearing supports.

Elevator motor: 1/2 hp, 1750 rpm, 90 VDC, TEFC

Elevator speed control: 25 fpm max.

Multistretch motor: 1/2 hp, 1750 rpm, 90 VDC, TEFC

Maximum static load: 20 000 lbs.

Maximum dynamic load: 8 000 lbs.

Minimum load: 350 lbs.

Turntable brake system: dynamic brake with pneumatic lock.

Maximum pallet load dimensions: 48" width x 56" length x 80" height

Minimum pallet load dimensions: 30" width x 30" length x (30" or 20" as determined by the film width) height

Load output: 60 loads per hour (dependent upon the desired wrap pattern)

Film roll: 20" or 30" wide

Film delivery: Multistretch I prestretch system with a dancer bar that controls the "force to load" compensation and compensates for load profile and speed.

Film cutoff and seal: full heat system

Dust tight controls.

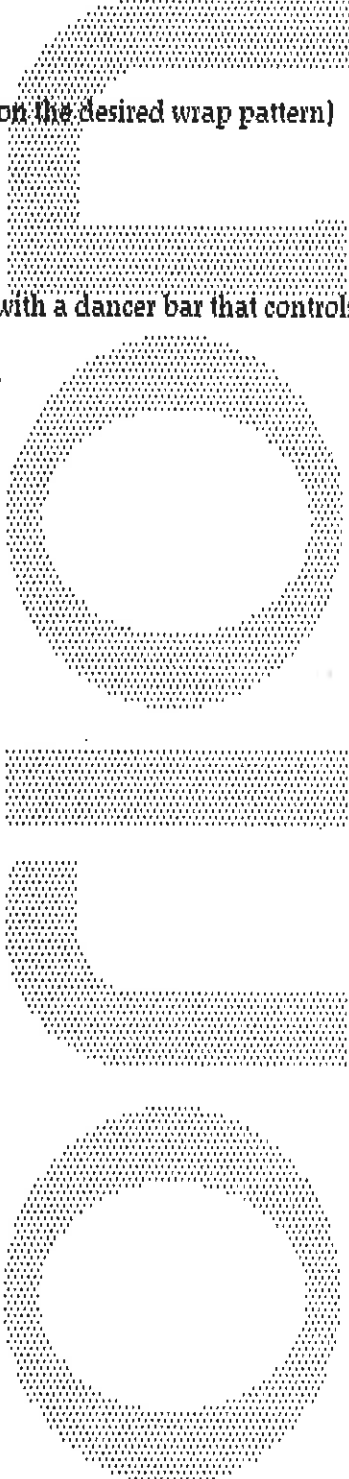

2.

STANDARD FEATURES

The standard, Fully Automatic stretchwrapper comes with,

- Automatic, programmed spiral wrapping,
- Heavy duty structural steel chassis,
- Multistretch I prestretch system,
- Infeed conveyor,
- Outfeed conveyor,
- Conveyorized turntable

The variable speed turntable is directly driven by a right-angle, worm and gear speed reducer, and an internal ring gear (slewing ring).

The carriage height is controlled by a variable speed, SCR controlled DC motor, with an automatic load height sensor and a broken film detector.

The turntable has a variable speed up to a maximum of 16 RPM with an automatic, dynamic braking system, and a pneumatic lock. The table conveyor is powered by a 1/2 hp motor using loop to loop power transmission between the rollers.

The conveyor units are driven by 1/2 hp, 90 VDC motors using the loop to loop system, and achieve a speed of 30 feet per minute.

The Multistretch I prestretch system has the capability of varying its prestretch through the use of change timing belt pulleys which are available through your Orion representative.

The re-wrap selector is also a standard feature, and the stretchwrapper is compatible with all major brands of film.

3.

OPTIONS

Power requirements:

- 575 VAC, 60 Hz, 3 phase, 30 Amps
- or 440 VAC, 60 Hz, 3 phase, 25 Amps
- or 240 VAC, 60 Hz, 3 phase, 20 Amps

Turntable system: up to 60" x 60" pallet size

Top platen.

Additional infeed and/or outfeed conveyors.

AC motors for the conveyor units (240 VAC standard).

Carriage for 20" film.

Carriage for 30" film.

Extended tower.

Caster turntable support system.

Chain conveyor.

Ninety degree (90°) discharge.

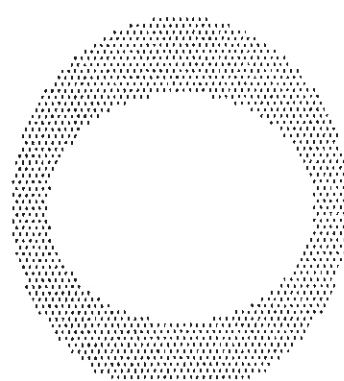
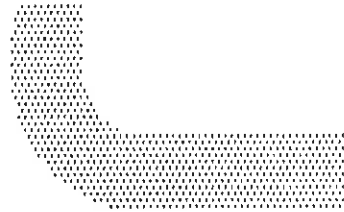
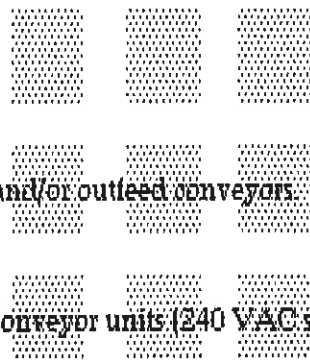
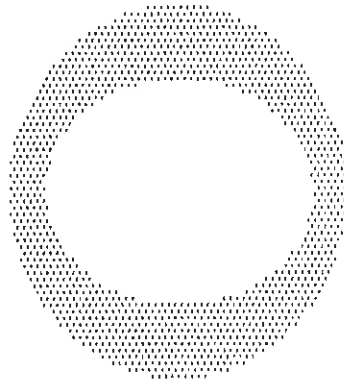
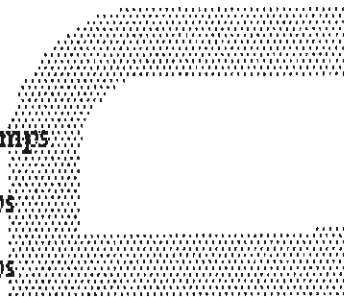

4. PARTS LISTS

4.1 TOWER PARTS LIST

The exploded assembly drawing of the Fully Automatic Tower is shown on drawing number 200 99.

Table 1 has the parts listed in order of part number. Note: the names given to the parts are generic.

TABLE 1

Tower Parts List

Part Number	Description	Quantity
10008	Idler sprocket	1
10009	#50 chain	1
10010	Cam follower (1 3/8 inch O.D.)	6
10018	Left carriage holder	1
10019	Right carriage holder	1
10063	Tower	1
10067	Cam follower (1/2 inch O.D.)	4
10069	Chain tensioner	1
10070	Chain tensioning screw	2
10071	Limit switch actuator	1
10074	Elevator drive sprocket	1
10076	Limit switch channel	1
10081	Chain cover	1
10087	Limit switch bracket	3
10091	Channel guide	3
10092	Knob	3

10093	Reducer	1
10095	Elevator motor (1/2 hp, 1750 rpm)	1
10123	Limit switch	3
10288	1/4-20 UNC x 1/2 SHCS	2
10289	Limit switch screw	6
10290	Channel screw (1/4-20 UNC x 1/2 SHCS)	2
10291	Transmission screw (3/8-16 UNC x 1 Hex bolt)	4
10292	Chain tensioner pin	2
10293	3/8-16 UNC x 1 long Hex bolt	2
10294	Cover screw (1/4-20 UNC x 1/2 SHCS)	3
10295	3/16 inch square key	1

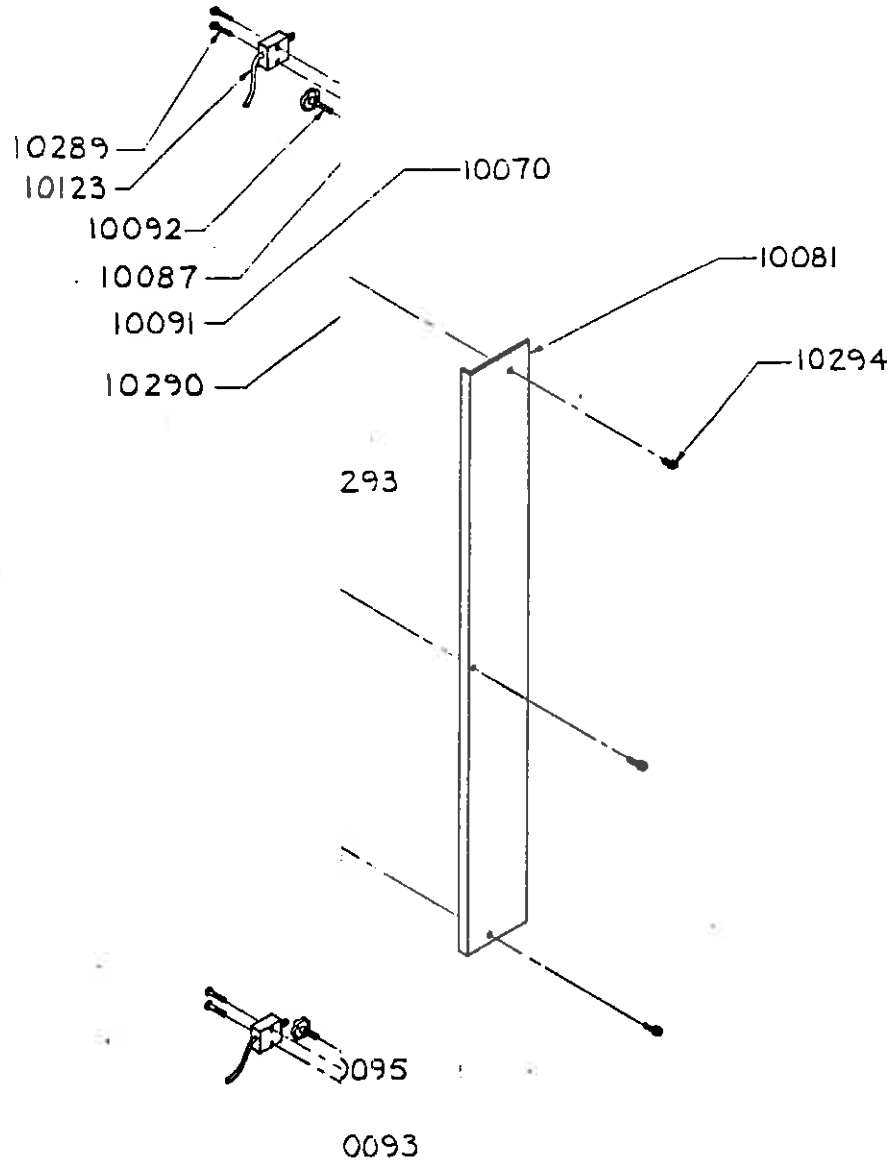

ORION PACKAGING MONTREAL		
SCALE: N.T.S.	APPROVED BY:	DRAWN BY VALENTIN
DATE: 27-6-86		REVISED
STD. TOWER ASSY		
L 44 H 44 L 55 H 55 PA 33	DRAWING NUMBER 200-99	

4.2 CARRIAGE PARTS LIST

The exploded assembly drawing of the Standard carriage is shown on drawing number 200 100. Table 2 has the parts listed in order of part number. Note: the names given to the parts are generic.

TABLE 2

Carriage Parts List

<u>Part Number</u>	<u>Description</u>	<u>Quantity</u>
10010	Cam follower (1 3/8 inch O.D.)	1
10015	20" Carriage frame	1
10016	30" Carriage frame	1
10017	Roller bracket	1
10020	Multiswitch mechanism cover	1
10021	Spacer	1
10022	Belt tensioner	1
10023	30" Pressure roller	1
10024	20" Pressure roller	1
10026	30" Center dancer roller	1
10027	30" Roller	1
10030	Top dancer lever	1
10031	Bottom dancer lever	1
10033	20" Center dancer roller	1
10034	20" Dancer roller	1
10037	30" x 3" dia. rubber roller	1
10038	30" x 4" dia. rubber roller	1

10039	20" x 3" dia. rubber roller	1
10040	20" x 4" dia. rubber roller	1
10042	3/4" flanged bearing unit	2
10043	1" Pillow block	1
10044	Prestretch driver pulley	1
10045	Potentiometer coupling	1
10046	Potentiometer bracket	1
10047	Film tension spring	2
10048	Spring adjustment screw	2
10049	Brake pad	2
10050	Film spool mandrel	1
10051	Top mandrel	1
10052	1" Collar	6
10054	Bottom mandrel	1
10058	Bronze bushing	2
10061	Prestretch transmission (5.1 worm & gear)	1
10068	Cover bracket	2
10091	Channel guide	1
10092	Knob	1
10118	Photoswitch	1
10121	Channel bracket	1
10122	30" Channel	1
10133	Prestretch driven pulley	1
10146	Timing belt	1
10155	20" Channel	1
10156	Photoswitch bracket	1
10157	3/4 inch pillow block	1

10227	3/16 inch square key	1
10296	Channel screw	2
10297	3/16 inch square key	1
10298	3/8-16 UNC x 1 long hex bolt	6
10299	Multistretch cover screw	3
10300	3/8-16 UNC x 2 long SHCS	1
10301	5/16-18 UNC x 2 1/2 long Hex bolt	4
10302	8-32 UNC x 1/2 long BHCS	8
10303	Bumper	2
10304	10-24 UNC x 3/4 long SHCS	2
10305	5/16-18 UNC x 3/4 long SHCS	2
10306	1/4-20 UNC x 3/4 long CHCS	2
10307	Feedback potentiometer	1
10308	10-24 UNC x 1/2 long SHCS	2
10309	1/4" square key	1
10310	10-24 UNC x 1 long SHCS	2
10368	3/8-16 UNC x 1 long hex bolt	4
10425	3/4" collar	1
30095	Prestretch motor (1/2 hp, 1750 rpm)	1

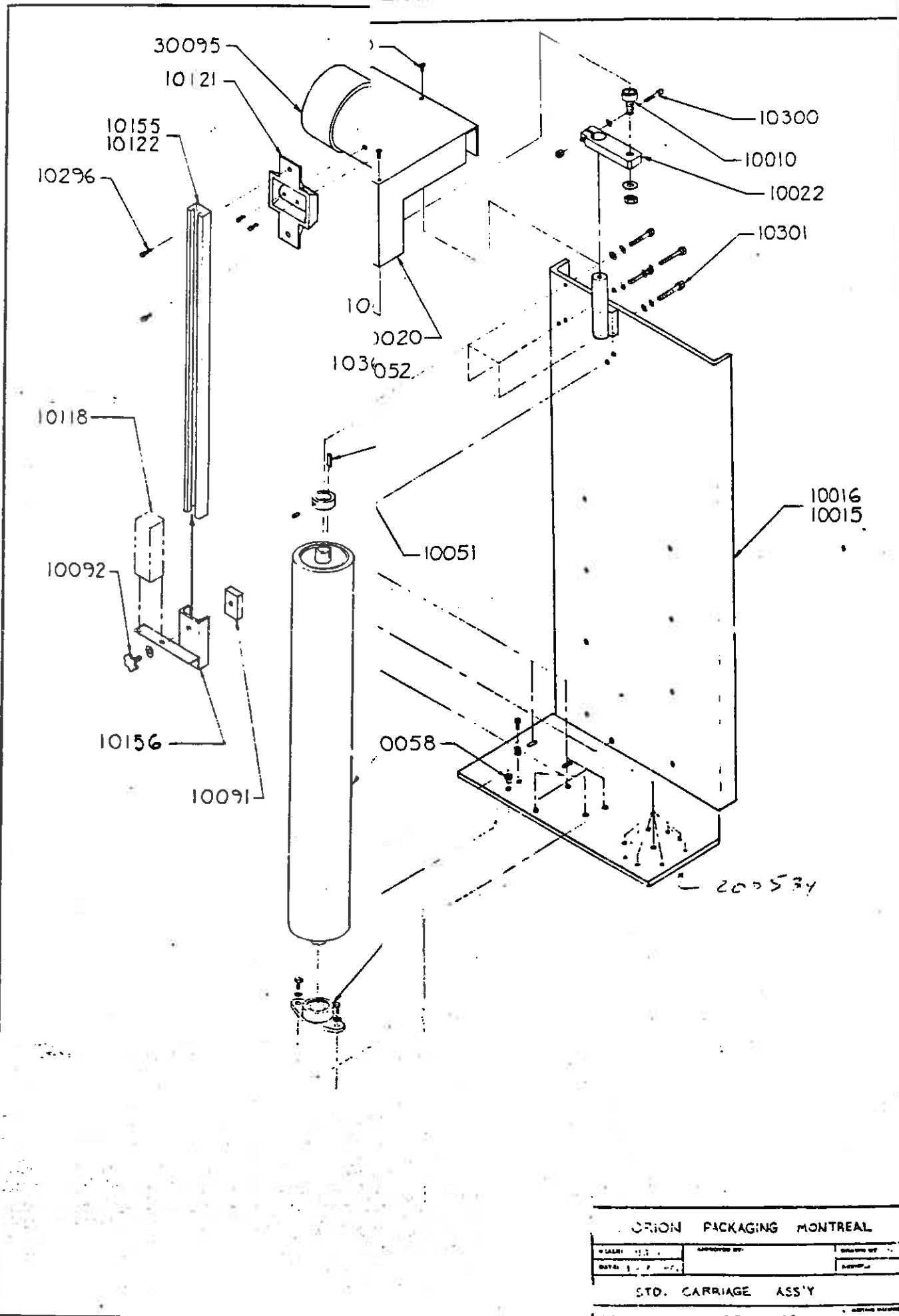

200534

ORION PACKAGING MONTREAL		
DESIGNER	APPROVED BY	DATE
DATE	APPROVED BY	DATE
STD. CARRIAGE ASS'Y		
44 55 66 PA33 PA33		

4.3 SEALING MECHANISM PARTS LIST

The exploded assembly drawing of the Sealing Mechanism is shown on drawing number 200 406. Table 3 has the parts listed in order of part number. Note: the names given to the parts are generic.

TABLE 3

Sealing Mechanism Parts List

Part Number	Description	Quantity
10027	30" Roller	1
10034	20" Roller	1
10158	Washer	1
10159	Cylinder tower plate	1
10160	Spacer	1
10161	Roller yoke	1
10162	Roller yoke	1
10163	Roller yoke	1
10164	20" Roper arm	1
10165	30" Roper arm	1
10166	20" Hot plate	1
10167	30" Hot plate	1
10168	20" Heater (two req'd in knife, one in hot plate)	3
10169	30" Heater (two req'd in knife, one in hot plate)	3
10170	20" Knife	1
10171	30" Knife	1
10172	20" Teflon film	1
10173	30" Teflon film	1

10174	20" Teflon film block	2
10175	30" Teflon film block	2
10176	Roper arm yoke	1
10177	1 1/2" Bore pneumatic cylinder	2
10178	7/16" Tie rod end	4
10179	Cylinder tower	1
10180	Roller yoke	1
10181	Knife thermostat	1
10182	Knife arm	1
10183	Knife arm yoke	1
10184	Knife bracket	1
10185	Hot plate arm	1
10186	2" Bore pneumatic cylinder	1
10187	5/8" Tie rod end	1
10188	Hot plate arm yoke	1
10189	5/8" UNF SHCS	1
10190	5/8" UNF hex nut	1
10191	7/16 UNF SHCS	4
10192	Hot plate holder	1
10193	Arm washer	4
10194	1 1/4" I.D. Bronze bushing	3
10255	5/16-18 UNC x 1 1/2 long SHCS	2
10256	Knife cover screw (#10 UNC)	6
10257	1/4-20 UNC x 1/2 long SHCS	8
10258	20" Teflon film plate	2
10259	10-24 UNC x 3/4 long SHCS	2
10260	1/4-20 UNC x 3/4 long CHCS	1

10261	10-24 UNC x 1/2 long CHCS	4
10262	7/16 UNF Hex nut	4
10263	Hot plate bracket	1
10264	1/2" Cylinder pin	1
10265	1/2" Retaining ring	1
10266	3/8" Retaining ring	2
10267	3/8-16 UNC x 3 long SHCS	6
10268	3/8" Cylinder pin	2
10269	7/16 UNC Hex nut	2
10270	7/16 UNF x 1 long SHCS	2
10271	Thermocouple screw	1
10272	Thermocouple	1
10273	7/16 UNC hex nut	2
10274	5/16-18 UNC x 1 1/2 long SHCS	2
10275	Hot plate bracket	1
10276	Teflon film spring	2
10277	1/4-20 UNC x 1 long SHCS	2
10278	3/8-16 UNC x 1 long CHCS	2
10279	10-24 UNC x 1/2 long Button head cap screw	6
10280	Spring bracket	2
10281	10-24 UNC x 3/4 long SHCS	4
10282	Teflon film bracket	4
10283	10-24 UNC x 3/4 long SHCS	8
10284	5/16-18 UNC x 1 1/2 long SHCS	2
10285	5/16-18 UNC x 1 1/2 long SHCS	4
10286	1/4-20 UNC x 3/4 long SHCS	4
10287	1/2-13 UNC x 1 1/2 long Hex bolt	1



13

10390

10-24 UNC x 1/2 long BHCS

10

10457

30" Teflon film plate

2

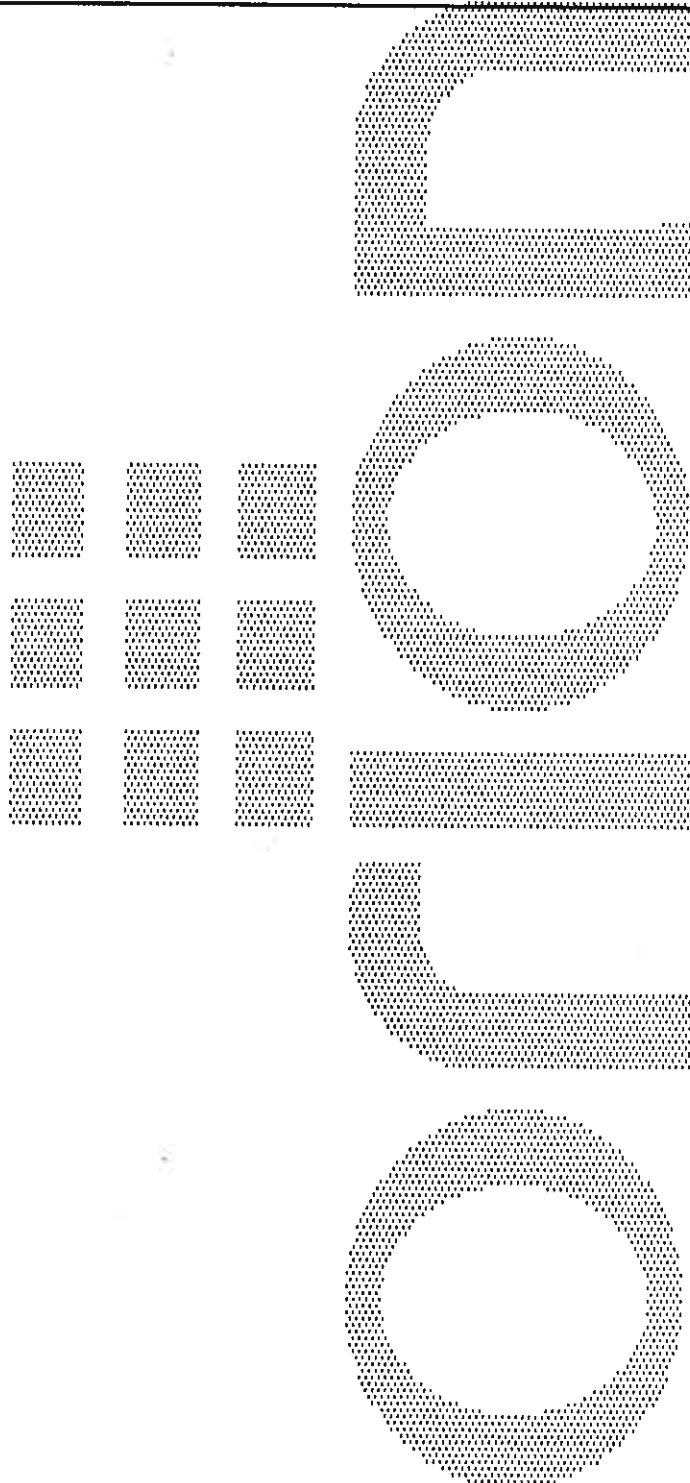

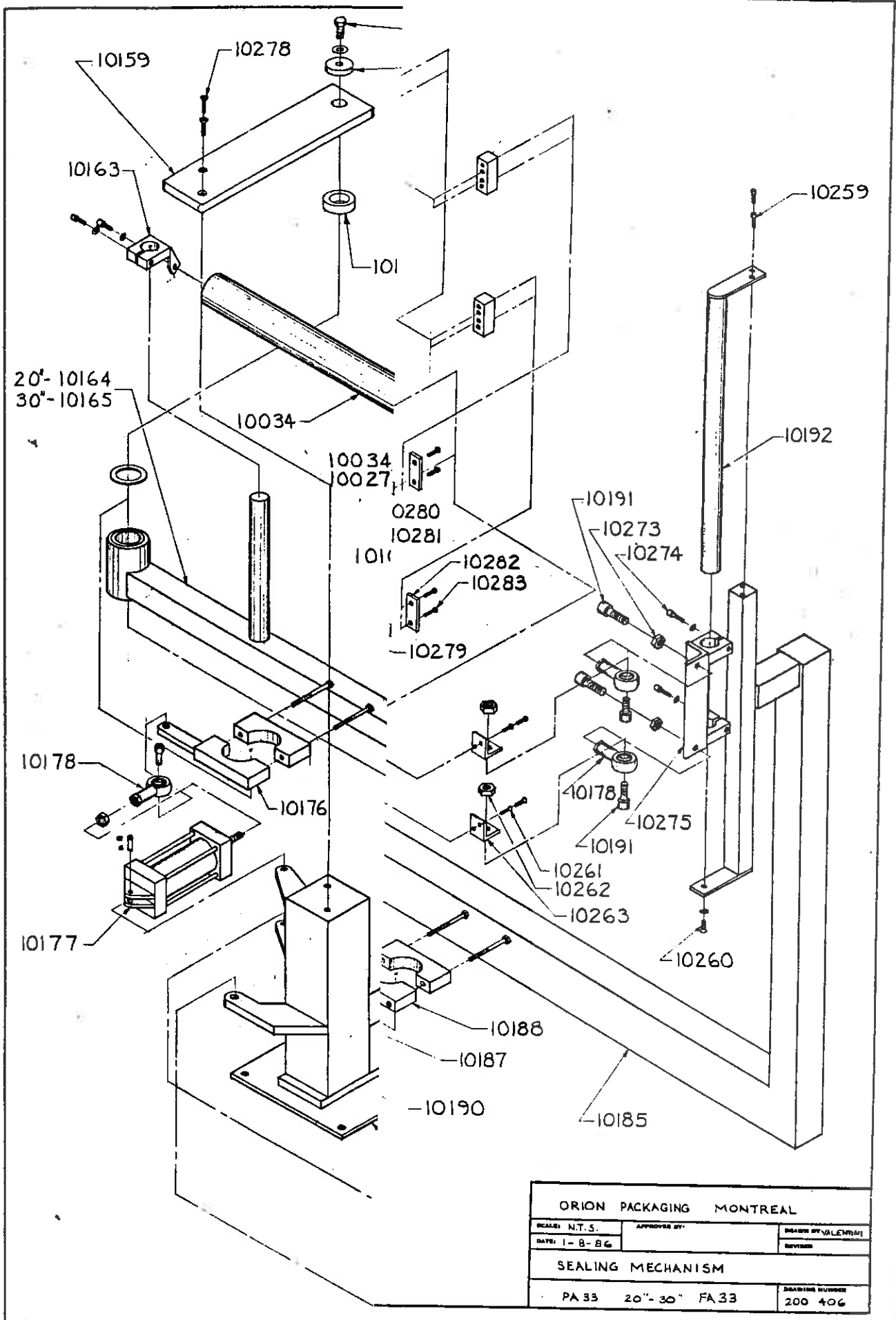

ORION PACKAGING MONTREAL		
SCALE: N.T.S.	APPROVED BY:	DRAWN BY VALENTIN
DATE: 1-8-86		REVISION:
SEALING MECHANISM		
PA 33	20"-30" FA 33	DRAWING NUMBER: 200 406

4.4 Base And Turntable Parts List

The exploded assembly drawing of the Fully Automatic Base is shown on drawing number 200 769. Table 4 has the parts listed in order of part number. Note: the names given to the parts are generic.

TABLE 4

Base And Turntable Parts List

Part Number	Description	Quantity
10392	Ring gear (107 teeth slewing ring)	1
10393	5/8-11 UNC x 2 long hex bolt	8
10394	Finion (19 teeth)	1
10395	1/4" square key	2
10396	3/8-16 UNC x 1 long hex bolt	8
10397	Turntable drive motor (1 1/2 hp, DC)	1
10398	Reducer (15:1)	1
10399	3/8-16 UNC x 1 long hex bolt	4
10400	Base frame	1
10401	3/8-16 UNC x 2 1/2 long hex bolt	4
10402	Clamp mechanism	1
10403	Clamp mounting plate	1
10404	3/8-16 UNC x 1 long hex bolt	40
10405	Pillow block bearing unit	20
10406	Double sprocket conveyor roller	10
10407	Conveyor frame	1
10408	1/2-13 UNC x 3 long hex bolt	10
10409	Conveyor drive chain	1
10410	Reducer mounting plate	1

10411	Reducer (40:1)	1
10412	5/16-18 UNC x 1 long CHCS	4
10413	3/16" square key	2
10414	Conveyor drive motor (1/2 hp, DC)	1
10415	3/8-16 UNC x 1 long	4
10416	Commutator and roto-seal assembly	1
10417	Turntable	1
10418	46" roller	2
10419	41" roller	2
10420	25" roller	2
10421	3/8-16 UNC x 1 long hex bolt	36
10422	Chain loop	11
10423	End roller sprocket	2
10424	Three hole, flanged bearing unit	12
10449	Lock cylinder	1
10450	Lock bracket	1
10451	Lock bolt	1
10452	Cylinder tower stand	1
10453	Valve cover	1
10454	Valve	1

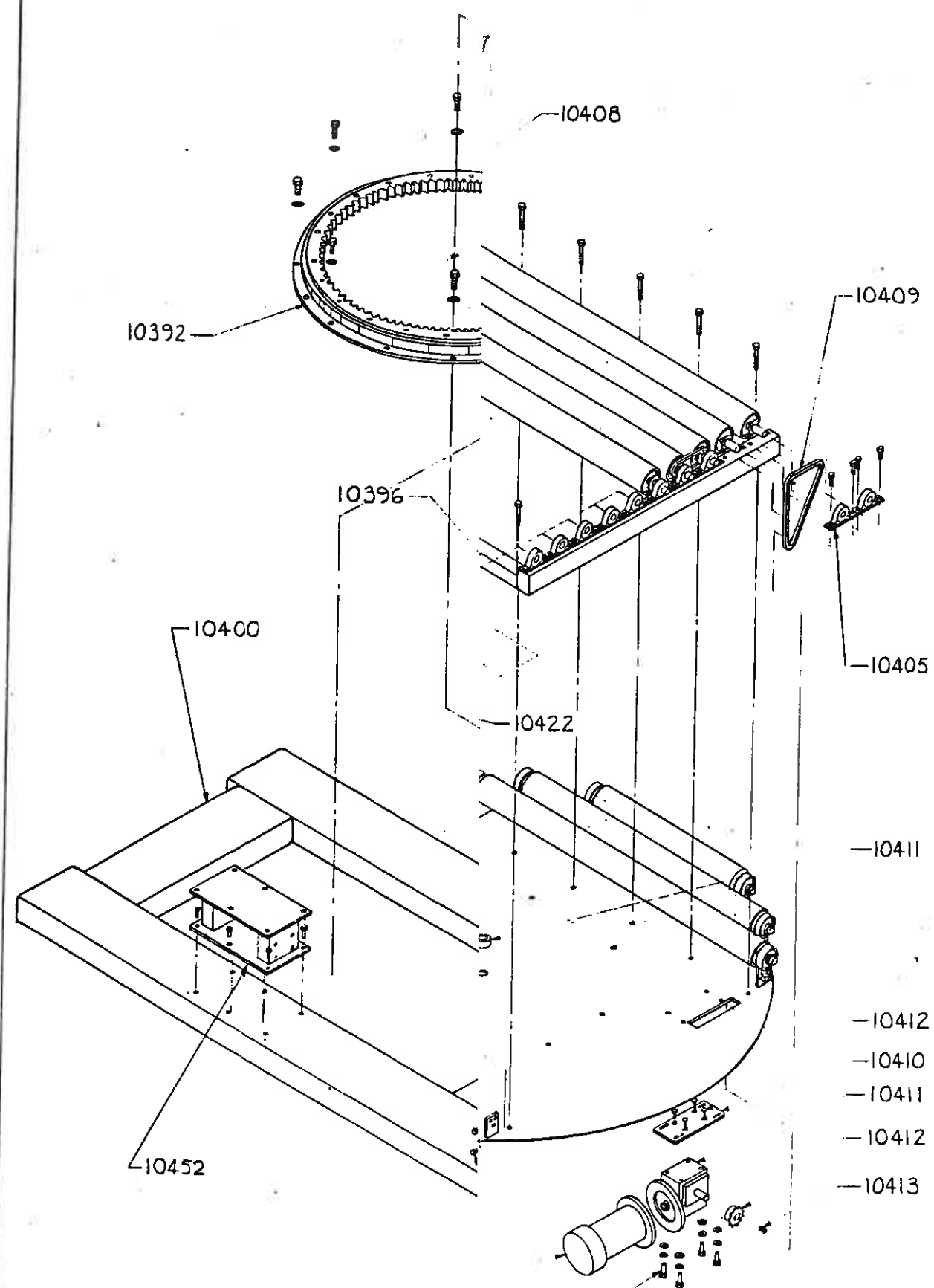

ORION PACKAGING INC.		
SCALE: 1:1	DESIGNED BY:	DRAWN BY: VALENTINI
DATE: 1-6-87		REVISED:
FULLY AUTOMATIC BASE ASSEMBLY		
FA33		200 769

4.5 Conveyor Parts List

The exploded assembly drawing of the conveyor unit is shown on drawing number 200 770. Table 5 has the parts listed in order of part number. Note: the names given to the parts are generic.

TABLE 5

Conveyor Parts List

Part Number	Description	Quantity
10426	3/8-16 UNC x 1 long hex bolt	66
10427	Fressed steel pillow block unit	30
10428	Drive chain	1
10429	Loop chain	15
10430	Single sprocket roller	1
10431	Double sprocket roller	13
10432	Conveyor height adjustment screw	4
10433	Motor (1/2 hp, DC)	1
10434	3/16" square key	2
10435	Drive sprocket	1
10436	Reducer (40:1)	1
10437	3/8-16 UNC x 1 long hex bolt	4
10438	Drive chain tensioning screw	1
10439	5/16-18 UNC x 1 long hex bolt	4
10440	Outfeed conveyor frame	1
10441	Leg	4
10442	8" roller	1
10443	Three sprocket roller	1

10444	7" roller	1
10445	Infeed conveyor frame	1
10446	Accumulator conveyor frame	1
10447	3/8-16 UNC x 1 long	4
10448	Three hole flanged bearing unit	2

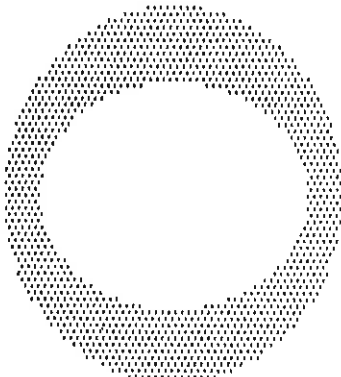
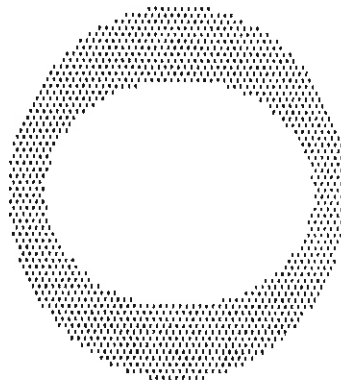
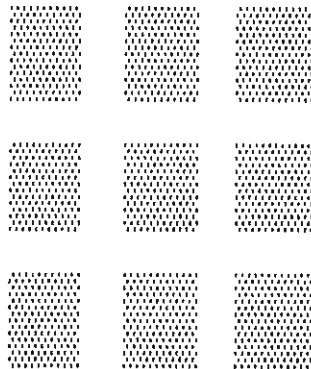

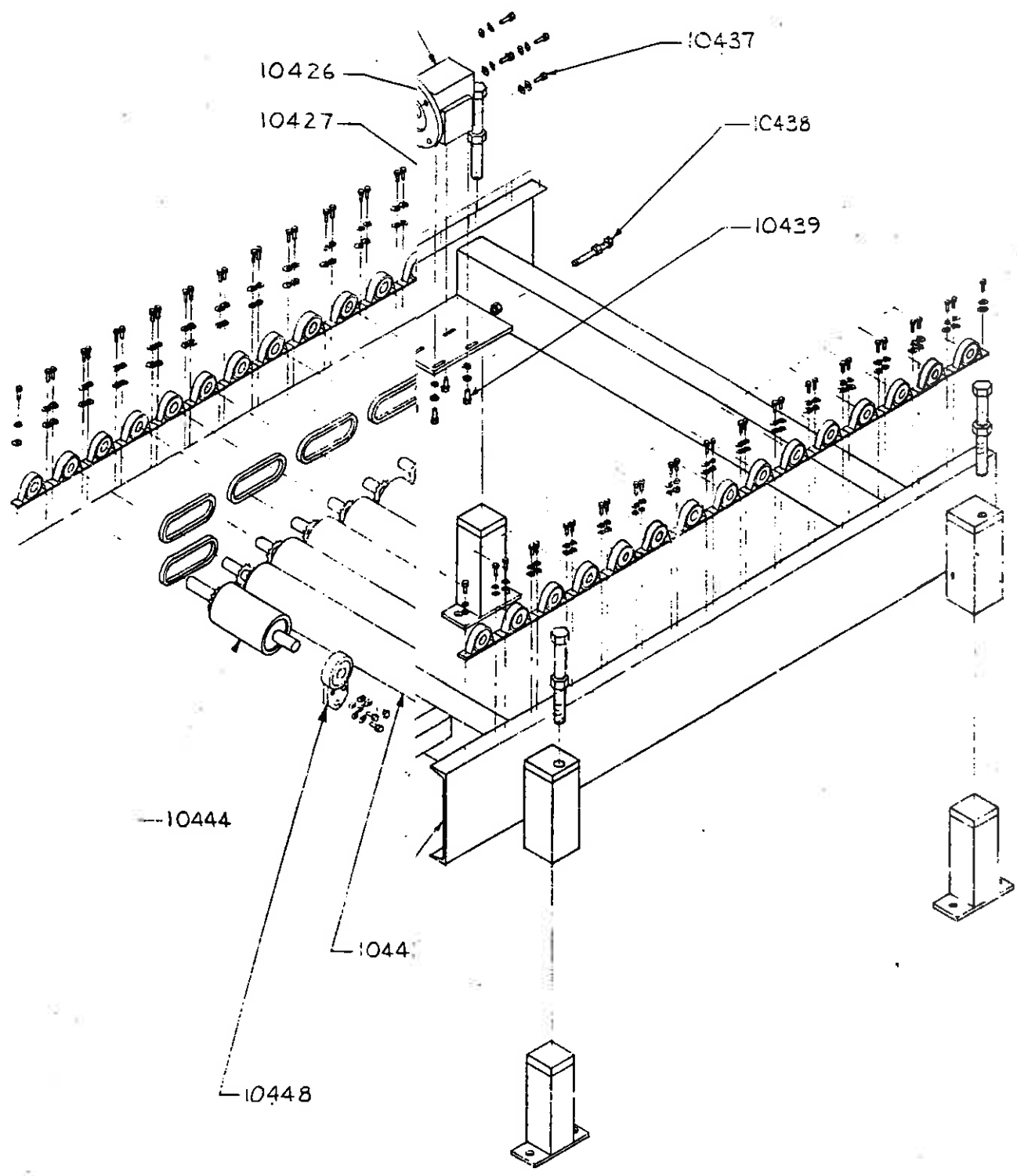

ORION PACKAGING INC.		
PRICE	475	DRAWN BY
DATE	3-7-67	VALENTINI
INFEED / OUTFEED/ACCUMULATOR ASS'Y		
CONVLYTOR		200 770

5. MACHINE INSPECTION AND INSTALLATION

5.1 Inspection Upon Arrival

CAUTION: When unloading the stretchwrapper, care must be taken not to lift it by the turntable. The forks of the forklift should be inserted in the 10 x 4 structural tube steel members in the base to lift the machine.

Before inspection, all packing and restraining blocks must be removed; these include the blocks under the carriage and between the heat seal arms.

CAUTION: When cutting the stretchwrap material covering the machine, care must be taken not to cut any electrical or pneumatic lines.

A visual inspection of all the electrical and pneumatic connections should be performed after unpacking the machine to check for loosened joints or broken connections. Any suspected shipping damage must be reported immediately to the freight carrier.

Items that are vulnerable to damage and must be inspected are,

- motor and transmission housings and connections under the turntable, under the conveyors, at the base of the tower, and on the carriage.
- the pneumatic valves and the filter-regulator-lubricator on the stretchwrapper base, next to the sealing mechanism.
- the pneumatic cylinders of the sealing mechanism and their hose connections.
- the pneumatic components and connections leading to the film clamp on the turntable, and the pneumatic lock under the table.

5.2 Machine Installation

After the visual inspection has been performed, the customer is required to provide the electrical and pneumatic power requirements as outlined in the specifications (sections 1, 2, and 3 of this manual).

The layout for positioning the machine components is given on drawing number 200 607; 20 fasteners of 1/2 inch diameter are required to fasten the standard machine to the ground. Eight more fasteners are required per conveyor added.

For the electrical connections, an electrical diagram is provided in the panel box and in the appendix of this manual. Also, a copy of the PLC's instruction manual is included in the appendix. Only a qualified electrical technician or an Orion representative should make the connections or effect any repairs on the machines.

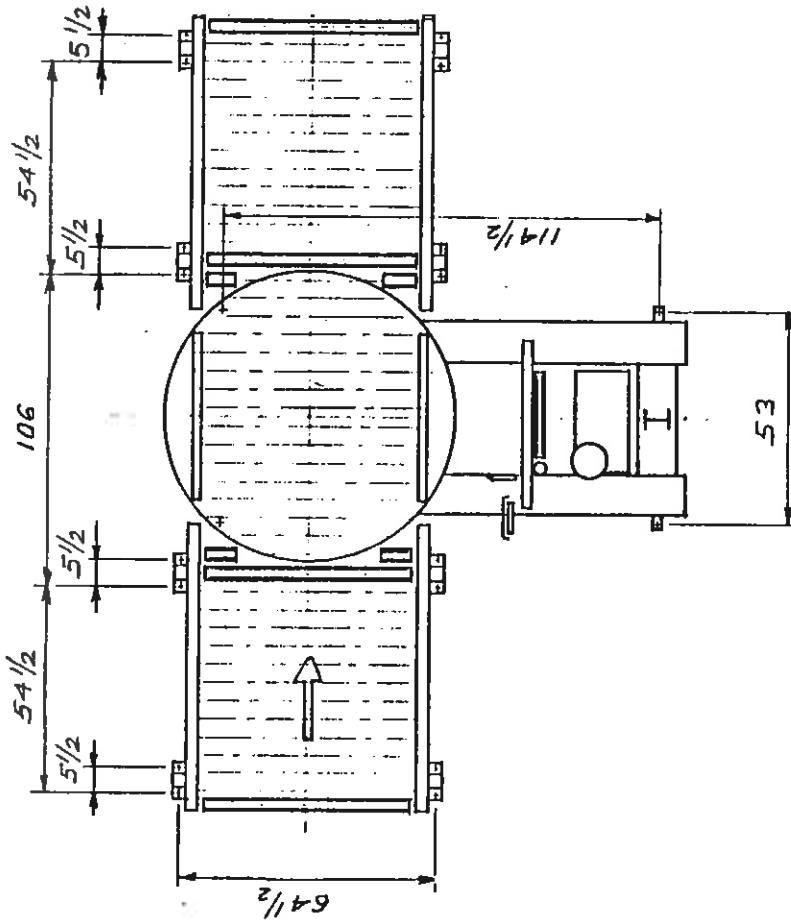

ORION PACKAGING INC.

SCALE: 3/8" = 1'-0" APPROVED BY:

DRAWN BY VALENTINI

DATE: 26-3-87 REVISED

STD. FULLY AUTOMATIC

FA-33

DRAWING NUMBER
200 607

6.

MANUAL CONTROLS AND START-UP

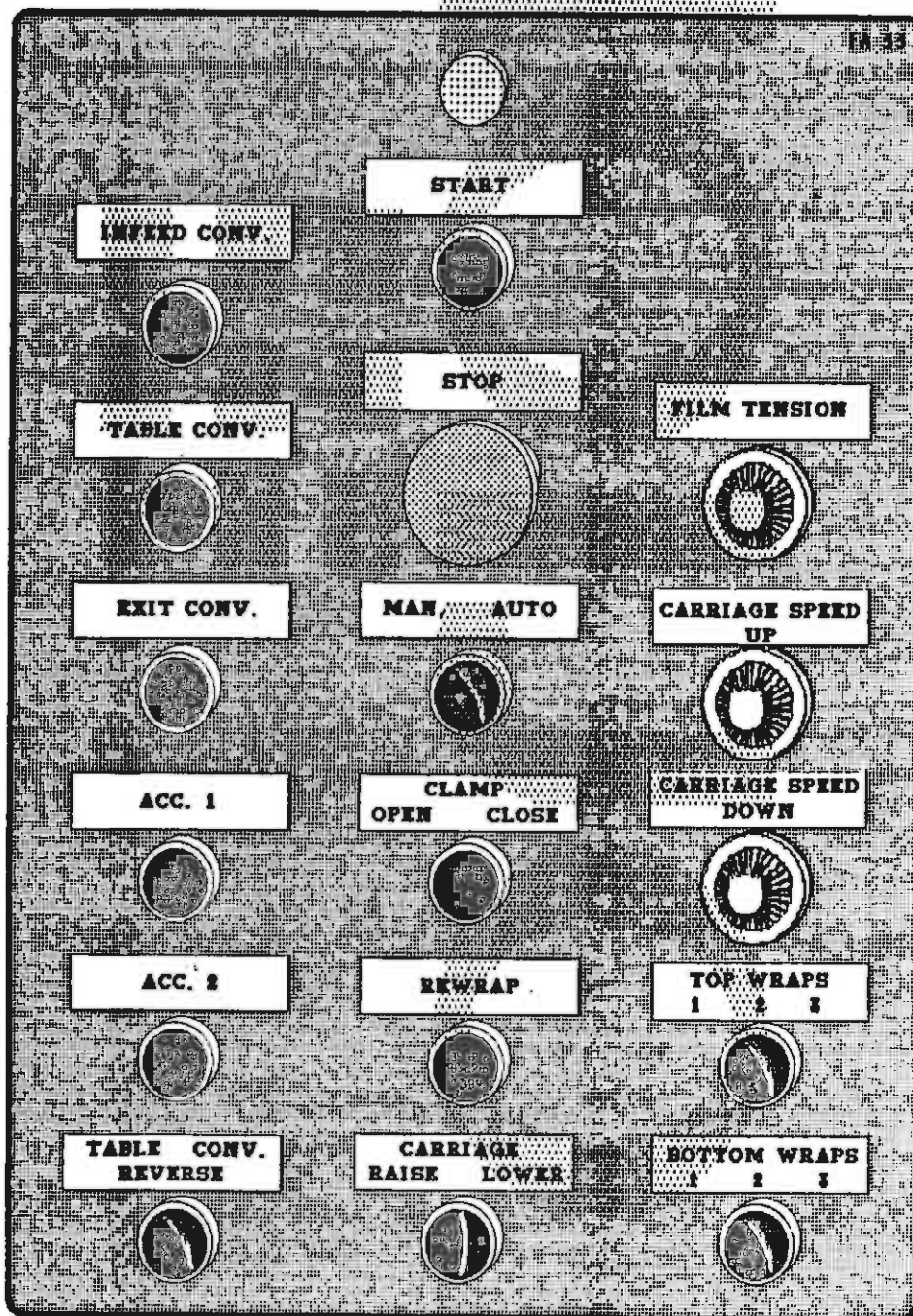

6.1 Power Switches

Main disconnect switch:

ON - connects a 240 VAC power source to the transformer.

OFF - disconnects the power source.

Power switch:

When the power switch is not activated, all the inputs of the machine are operative but the outputs will remain disabled. This is a useful aspect for troubleshooting since the signals may be traced at the PLC without having the machine operate. When the power switch is activated, the outputs are enabled and the machine will resume normal operation.

6.2 Operation Mode Selector Switch

The two settings on the operation mode selector switch are,

MANUAL - Manual operation: for use in machine testing, operation set-up, or troubleshooting.

AUTO - Automatic operation: for use when using the programmed commands of the automatic cycle.

When the switch is set to MANUAL, the manual control switches are enabled. In order to begin machine testing or operational set-up, the operation mode selector must be set to MANUAL. This will permit the operator to use the manual control switches described in this section.

When the mode selector switch is set to AUTO, the programmed commands stored in the PLC are operative and the START CYCLE button may be pressed to permit normal automatic operation. The STOP button may be pressed to stop the cycle during operation. The mode selector switch may be switched from AUTO to MANUAL during the cycle for a transfer to manual operation.

6.3 Conveyor Control Switches

The conveyor control switches are three push-button switches that activate the conveyors when held depressed. These switches are,

INFEEED CONVEYOR,

TABLE CONVEYOR,

EXIT CONVEYOR,

These three conveyors and switches come with the standard FA 33 stretchwrapper. Any optional, additional conveyors would be labelled as follows.

ACCUMULATOR 1,

ACCUMULATOR 2,

...etc.

The Accumulator control switches are also push-button switches that activate the accumulator conveyors as long as the switches are held depressed.

The TABLE CONVEYOR REVERSE switch is a monostable, two position switch that reverses the direction of motion of the table conveyor when activated.

These conveyor control switches may be used during operation set-up, or troubleshooting, and can only be used when the Operation Selector is set to MANUAL.

6.4 Carriage Control Switch

The Carriage Control switch is a monostable three position switch with the following settings,

RAISE - Raises the carriage until the photoswitch senses that the carriage has reached the same level as the top of the load.

LOWER - Lowers the carriage until the bottom limit switch on the tower is activated.

The switch is normally in the middle position where the carriage remains stationary. Turning the switch to the RAISE or LOWER position will activate the carriage to move in its respective direction.

The carriage control switch will only work when the Operation Selector switch is set to MANUAL, and will raise the carriage only if there is a load on the turntable.

6.5 Stop switch

The Stop switch is a push-button switch that, when pressed, disables all the outputs coming from the PLC and resets the cycle. When the button is pressed in the middle of the cycle all operations will stop except for the turntable which will stop once it reaches 'home' position.

NOTE: To restart the cycle, the carriage and the loads must be repositioned using the jog buttons in the MANUAL mode.

6.6 Clamp Jog

The Clamp Jog is a bistable push-button switch that opens the clamp when pressed once and closes the clamp when pressed again. The monostable action is achieved through the use of a four-way pneumatic valve mounted on the turntable next to the clamp. The clamp jog will only work when the Operation Selector switch is set to MANUAL.

6.7 Rewrap Selector

The rewrap selector is a push-button switch that restarts the wrap cycle during the automatic operation. The Rewrap will only work when the Operation Selector switch is set to AUTO, and a load is in the proper position for wrapping on the turntable.

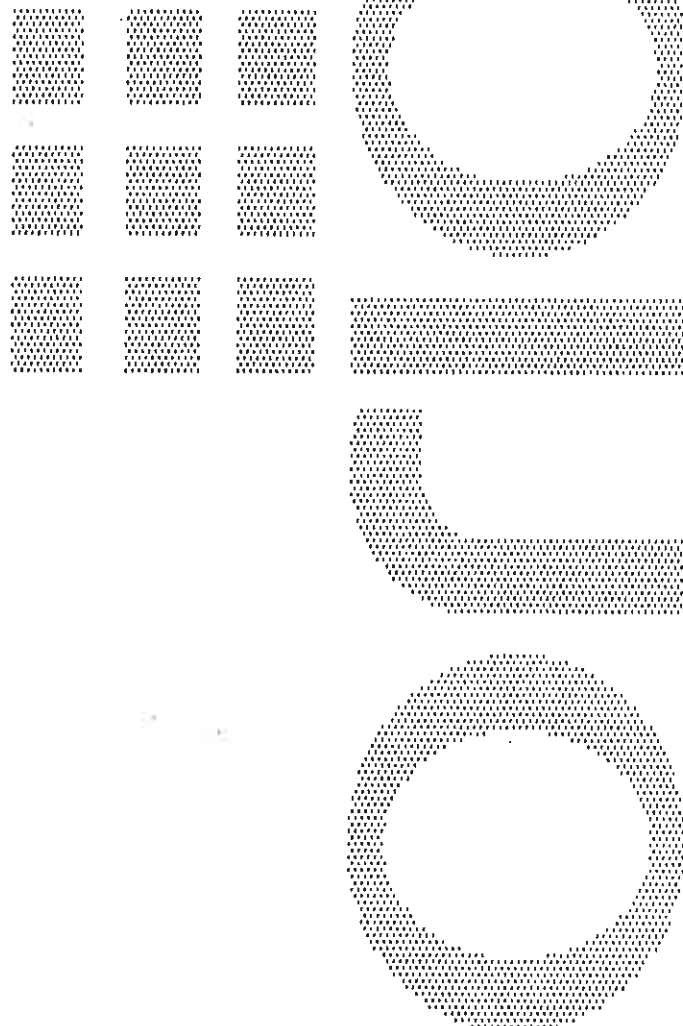

7. CYCLE ADJUSTMENT CONTROLS

7.1 Film Tension

The film tension may be adjusted through the film tension control potentiometer. The pot has a range of tension from 0 to 10, 10 being the highest tension rating. This pot may be adjusted during the automatic cycle or when the Operation Selector switch is set to AUTO.

CAUTION: Light loads may require lower tension settings than heavier loads.

The film tension is controlled through the dancer bar system. Occasionally the feedback potentiometer may need some adjustment. The adjustment of the feedback potentiometer can be performed while there is no film on the carriage. The bottom screw on the potentiometer coupling must first be loosened. Once the screw is loosened the potentiometer shaft must be turned until the prestretch motor just begins to hum but does not rotate, at which point the screw can be tightened. **NOTE:** the condition in which the motor hums but doesn't turn must be maintained even after the screw is tightened, if not, the adjustment procedure must be repeated.

7.2 Carriage Speed

There are two carriage speed controls on the panel.

CARRIAGE SPEED UP,
CARRIAGE SPEED DOWN.

The carriage speed controls can be used to control the amount of overlap the film will have on itself during a wrap. It is recommended to start with a RAPID upward wrap in order to stabilize the load early in

the cycle.

The control potentiometers have settings from 0 to 10, the higher settings being the fastest. High settings will mean less film overlap because of faster carriage speed, and low settings will mean more film overlap because of lower carriage speeds.

7.3 Top And Bottom Wraps

There are two bistable, three position, switches which control the number of wraps that may be put at the top and bottom of the load.

TOP WRAPS - 1, 2, 3

BOTTOM WRAPS - 1, 2, 3

These switches may be set before the automatic cycle begins, and in their different positions will wrap respectively 1, 2, or 3 turns of film on the top or bottom of the load.

7.4 Turntable Speed Adjustments

The turntable speed may be changed by adjusting the controls on the 750 or 850 board inside the panel. The controls on the board regulate the steady-state speed, the jog speed, and the acceleration and deceleration of the turntable. The controls are labeled on the board and listed below:

ZERO - The zero adjustment controls the deadband voltage for the turntable motor; it should be adjusted so that the motor just begins to hum but does not turn.

PRESET 1 - The preset 1 controls the FAST speed of the turntable.

PRESET 2 - The preset 2 controls the jog speed of the turntable.

PRESET 3 - The preset 3 controls the slow speed of the turntable.

DN 1 - The DN 1 adjustment regulates the rate of deceleration of the turntable for when it reaches the end of the cycle at the fast speed.

DN 3 - The DN 3 adjustment regulates the rate of deceleration of the turntable for when it reaches the end of the cycle at the slow speed.

UP - The UP adjustment regulates the rate of acceleration of the turntable for the beginning of the cycle.

IRC - The IRC needs only adjustment if there is a very large range of load weight; for most applications it will not need to be adjusted but if adjustment is necessary, contact your Orion representative.

CL - The CL is factory set and needs no further adjustment.

8. MACHINE MONITORING SWITCHES

8.1 Photoswitches

Photoswitches are placed on the machine to monitor the motion and location of the loads on the conveyors. There are a total of six photo-switches located on the standard FA 33. There will be an additional photo-switch for each optional, additional conveyor on the machine.

The photoswitches are located as follows,

1) Load height sensing photoswitch: this switch is located on the carriage and stops the carriage from moving higher than the highest point on the load.

The photoswitch's position on the track can be adjusted in order to make the carriage pass the top of the load and make the film overlap the top.

2) Turntable load location photoswitch: this photoswitch is the middle of the three photoswitches that are pointed at the turntable from behind the tower; its purpose is to stop the load on the turntable in a suitable position for wrapping. The turntable conveyor is programmed to stop approximately 1.5 seconds after this photoswitch is activated.

3) Turntable safety photoswitches: these photoswitches are the outside of the three photoswitches that are pointed at the turntable from behind the tower; their purpose is to prevent the cycle from starting if the load is not properly positioned on the turntable.

4) Infeed and outfeed photoswitches: there is one photoswitch located approximately one foot from the exit end of each conveyor; their purpose is to monitor the position of the loads as load transfers are occurring. When the photoswitch is activated by a load there is a delay of approximately 1.5 seconds before the conveyor stops. NOTE: when testing the conveyor without a load the photoswitch must be

kept activated for at least 1.5 seconds in order to have the conveyor stop. For a downstream conveyor, when the load is moved out of the photoswitch's range there will be a delay of about 5 seconds before an upstream conveyor is activated to move another load.

8.2 Limit Switches

There are three limit switches located on the tower. The topmost and bottom-most switches limit the motion of the carriage to that determined by the location of the elevator's drive and idler sprockets. The middle limit switch's purpose is to cause the clamp to open once the carriage reaches its level and activates the switch.

CAUTION: These limit switches are factory adjusted and, unless they have been disturbed, should not need any further adjustment.

8.3 Proximity Switch

The only proximity switch is located under the turntable, next to the turntable lock. Its purpose is to monitor the turntable's position and to signal the controller every time the turntable passes home position. The proximity switch's proper adjustment ensures that the turntable will stop in the correct position for the lock to be activated.

CAUTION: The proximity switch is factory adjusted and should not need any further adjustment unless it has been disturbed.

8.4 Knife Thermostat

The knife thermostat controls the temperature of the knife and may be adjusted with a screw driver as shown in drawing number 200 159.

8.5 Broken Film Sensor

When the machine runs out of film, or when the film breaks, the machine will stop, the red light on the panel box will turn on, and an alarm will sound. The Stop button may be pressed to stop the alarm.

WARNING: The machine must be turned OFF and the POWER DISCONNECTED before feeding the film through the rollers. Failure to do so can result in serious injury to the operator and damage to the machine.

9. MACHINE MAINTENANCE

9.1 Speed Reducer Maintenance

On the reducing transmission, after the first week all external cap screws and plugs should be checked for tightness. It is recommended to change the oil every six months or every 2500 hours of operation, whichever comes first. When adding oil the transmission should never be filled above the oil level mark indicated because leakage and overheating may occur. Below is a list of the type of lubricant that should be used.

Manufacturer	Lubricant
American Oil Co.	American Cyl. Oil No. 196-L
Cities Service Oil Co.	Citgo Cyl. Oil 180-5
Gulf Oil Corp.	Gulf Senate 155
Mobile Oil Corp.	Mobil 600 W Super Cyl. Oil
Phillips Oil Co.	Andes S 180
Texaco Inc.	624-650T Cyl. Oil
Shell Oil Co.	Velvata Oil 182
Union Oil Of Cal.	Red Line Worm Gear Lube 140

Reducing transmissions are found under each conveyor unit, under the turntable, on the carriage, and at the base of the tower.

9.2 Ring Gear Maintenance

The ring gear is located under the turntable and should be lubricated at fixed intervals. This should be carried out by injecting grease into all the lubrication nipples in succession until a collar of fresh grease appears around the perimeter of both sealing rings. The bearing could be rotated slowly during lubrication.

The relubrication interval depends on the operating conditions. For bearings exposed to an aggressive environment, relubrication should occur every 50 operating hours. Normally, relubrication should occur every 100 to 200 hours of operation. The gear teeth should also be relubricated. Lubricants of different manufacture recommended for the ring gear are shown below.

Manufacturer	Raceway Grease	Gear Teeth Oil
BP	Energrease LS 2	Energol WRL
Castrol	Spherol AP 2	Grippa 33 S
ESSO	Beacon 2	Surret Fluid 30
Gulf	Crown Grease No. 2	Lubcote No. 2
Mobil	Mobilux 2	Mobiltac E
SHELL	Alvania Grease R 2	Cardium Compound C/Fluid C
Texaco	Glissando FT 2	Crater 2 X Fluid
Valvoline	LB-2	EGC

9.3 Motor Maintenance

An occasional inspection of the brushes should be made in order to establish a wear rate. Replacement brushes should be installed before old brushes wear to 9/16" long, measured on the long side. After replacing brushes run the motor near rated speed for at least 1/2 hour with no load to seat the new brushes.

Failure to properly seat the new brushes may cause commutator damage and rapid wear of the new brushes. If the commutator becomes rough, scored, or out of round, a competent motor shop should disassemble the motor and resurface the commutator. With every third brush change, have a competent motor shop resurface the commutator and blow the carbon dust out of the motor.

9.4 Chain Maintenance

To clean and relubricate chains, wipe them with an oily cloth every month. If the environment is very dusty or damp, it may be necessary to clean and relubricate the chains more often.

With time the elevator chain will tend to stretch. A loose chain should be tightened at the chain tensioner as shown on drawing number 200.192.

9.5 Cam Follower Maintenance

The cam followers behind the carriage, on the tower, have deep grease pockets and need not frequent relubrication.

9.6 Pneumatic System Maintenance

The air supply system must be checked weekly and must be free from moisture. In humid environments it may be necessary to drain the air supply system daily. The air lubricator should be kept filled to approximately 3/4 of its full capacity, an SAE #10 oil should be used.





RECOMMENDED SPARE PARTS LIST

Fart Number	Description	Drawing Number
10008	Elevator idler sprocket	200 99
10010	Cam follower (1 3/8 inch diameter)	200 99, 100
10034	20" dancer roller	200 100, 406
10039	20" x 3" dia. rubber roller	200 100
10040	20" x 4" dia. rubber roller	200 100
10047	Film tension spring	200 100
10061	Reducer (5:1 BQ133)	200 100
10067	Cam follower (1/2 inch diameter)	200 99
10093	Reducer (50:1 BQ175)	200 99
10095	Motor (1/2 hp DC)	200 99
10123	Limit switch	200 99
10146	Timing belt	200 100
10168	20" heater	200 406
10177	1 1/2" bore pneumatic cylinder	200 406
10186	2" bore pneumatic cylinder	200 406
10195	Clamp assembly (PA)	200 196
10206	Motor (1 hp, 90 vdc, PA)	200 196
10307	Feedback potentiometer	200 100
10397	Motor (1 1/2 hp, DC)	200 769
10398	Reducer (20:1 BQ262)	200 769
10402	Clamp assembly	200 769
10411	Reducer (50:1 BQ175)	200 769



10416	Commutator and roto-seal assembly	200 769
10454	Clamp 4-way valve	200 769
10457	Hot plate assembly	200 406
10458	Knife assembly	200 406
10459	Lock assembly	200 769
10463	Reducer (BQ175, 40:1)	200 770

ELECTRICAL BOARDS:	336 (236)
	168-4 (168-3)
	750M-240v
	850C

Note: This spare parts list is for the stretchwrapper with a carriage for the 20" wide film.

FOR A HIGHER TEMPERATURE
ADJUSTMENT TURN CCW

FOR A LOWER TEMPERATURE
ADJUSTMENT TURN CW

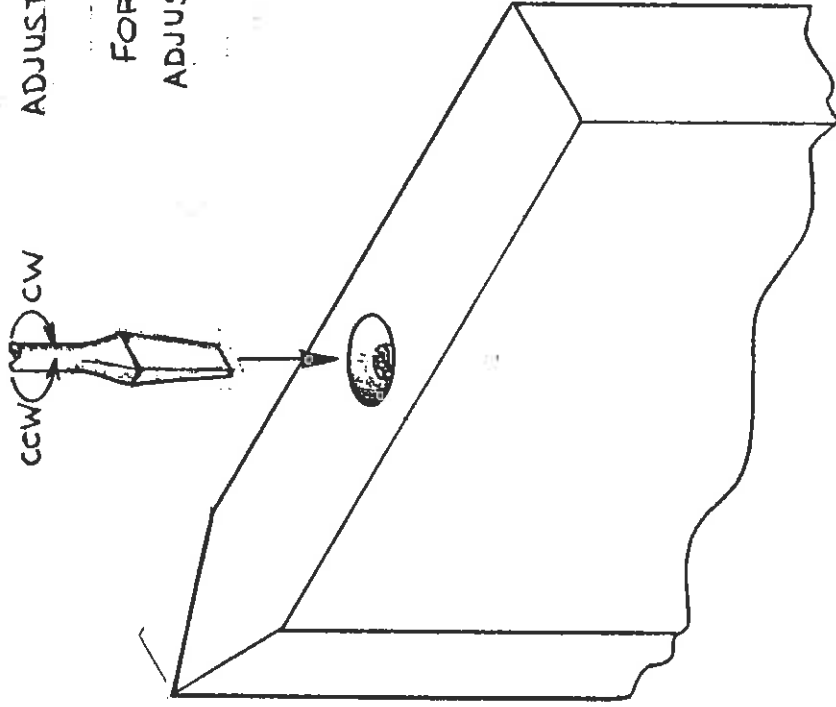

ORION PACKAGING

SCALE: N.T.S

DATE: 17-6-86

APPROVED BY:

DRAWN BY VALENTINI

REVISED

THERMOSTAT ADJUSTMENT

PA

DRAWING NUMBER
200 159

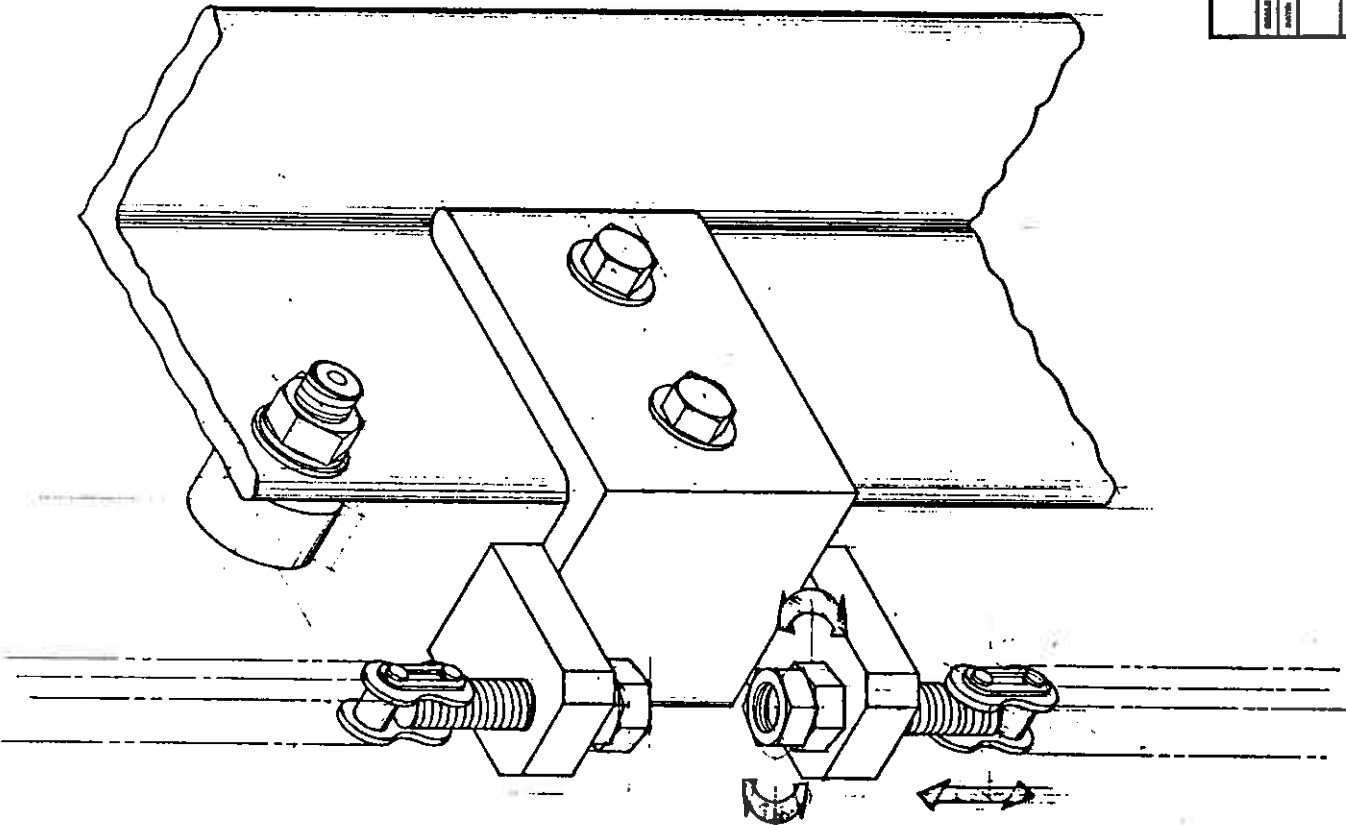

CHAIN TENSION
ADJUSTMENT

ORION PACKAGING		DESIGNED BY (MAG/UTM)
MODEL: N.T.S.	APPROVED BY:	DATE:
SCALE: 10 - 7 - 85		
CHAIN TENSIONER ASS'Y		REVISION NO. 200 - 1

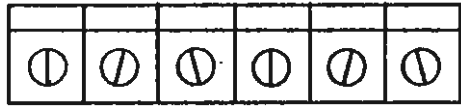

1. 2 ZERO

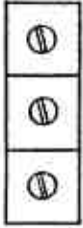

5



4



3



6



ZERO : TURTABLE DEADBAND ADJ.

1 : STEADY STATE SPEED ADJ.

2 : JOG SPEED ADJ.

3 : ACCELERATION ADJ.

4 : DECELERATION ADJ.

5 : LOAD RANGE ADJ.

6 : CURRENT

ORION PACKAGING INC.

ECHILLE: N.T.S.
SCALE: APPROUVE PAR:
APPROVED BY:

DATE: 23-12-87

DESSINE PAR: VALENTINI
DRAWN BY:

REVISE PAR:
REVISED BY:

750 M

NUMERO DE DESSIN
DRAWING NUMBER

210 142 A

168-4	DC-	▬
	DC+	▬
	AC2	▬
	AC1	▬
	1	▬

ORION PACKAGING INC.	
ECHELLE: N.T.S.	APPROUVE PAR: APPROVED BY:
SCALE:	REVISIONS:
DATE: 16-9-87	REVISIONS:
168-4	
DESSINE PAR: VALENTINI	
DRAWN BY:	
REVISE PAR:	
REVISED BY:	
NUMERO DE DESSIN DRAWING NUMBER	
200 892	

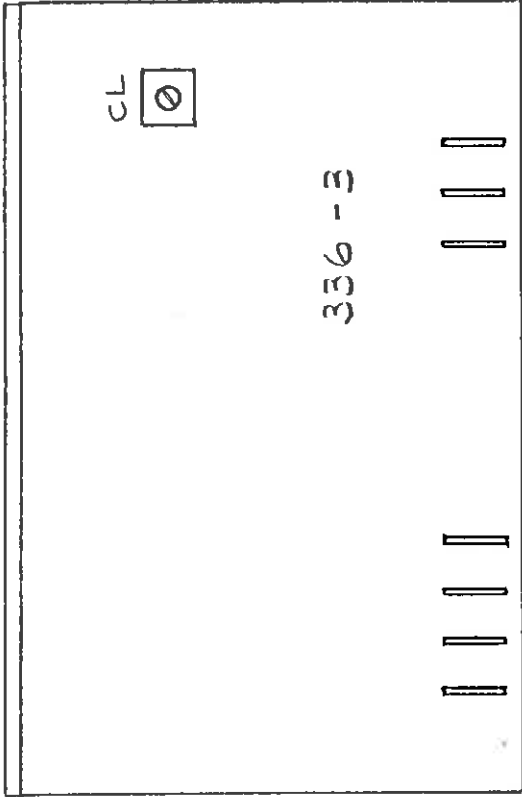

CL : CURRENT LIMITER

ORION PACKAGING INC.	
ECHELLE: N.T.S. SCALE:	APPROUVE PAR: APPROVED BY:
DATE: 16-9-87	DESSINE PAR: VALENTIN. DRAWN BY:
336-3	
REVISE PAR: REVISED BY:	
NUMERO DE DESSIN DRAWING NUMBER 200 890	

Type 42SRU AC/DC Long Range Visible LED Beam Reflex Control Series 6000

Mini-sized photoelectric sensors
with adjustable sensitivity
wide supply voltage range
and
power MOSFET output

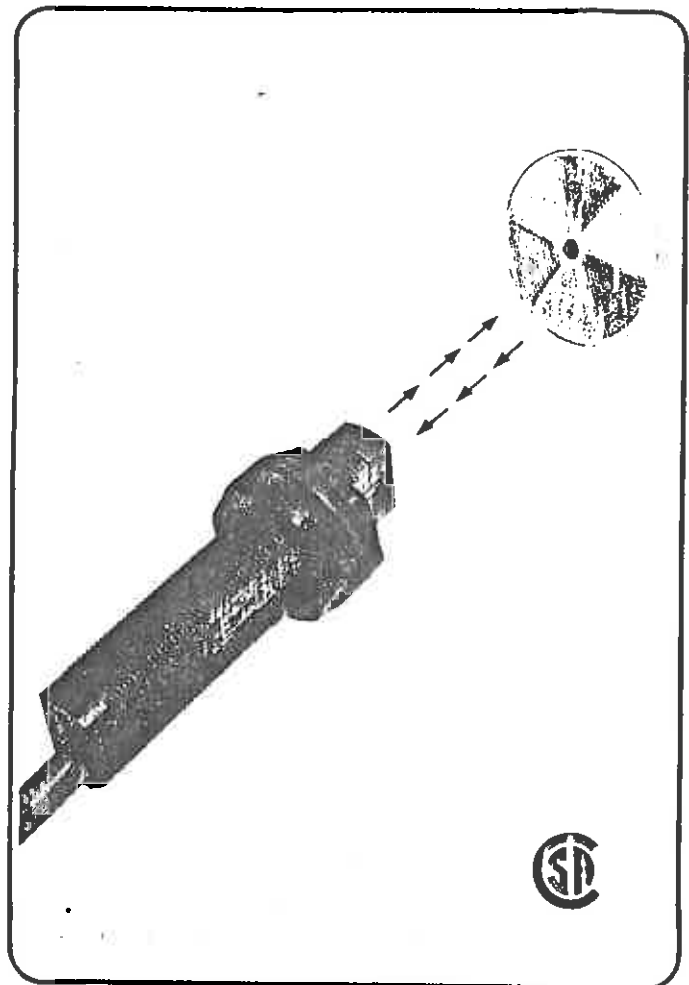

FEATURES

- Minimum size with maximum operating features
—.5"W x 1"H x 3.6"D
- Four ways to mount the control
- Visible LED beam
—simplifies alignment and inspection
- Rated operating distance to 20 feet (6.1 meters)
—with adequate operating margins for normal industrial environments
- Two 3-wire AC/DC models operate from
—20 to 132 VAC or DC
—20 to 264 VAC or DC
- Low power consumption - 1.2 VA
- Solid state power MOSFET AC/DC output
—rated 300 mA for 120V models
—rated 150 mA for 240V models
- LIGHT OPERATE and DARK OPERATE models
- Sensitivity adjustable over wide range
- Synchronous Detection to minimize ambient noise
- No False Turn-On Pulse
- Protected against line voltage transients
- Fast operating response
- Fully Encapsulated with Thick film Microcircuitry for Quality and Reliability
- Nema 3, 4, 12, and 13 Corrosion Resistant, High Impact Housing
- LED Alignment and Output Indicator
- Control Includes 10 feet (3 meters) of UL Recognized Type SJTO cable
—Not required to be enclosed in conduit
—Reduces installation cost
- Designed to meet UL requirements
- CSA Certified

PHOTOSWITCH[®]

GENERAL

Type 42SRU Series 6000 AC/DC Long Range Reflex mini-sized self-contained photoelectric controls literally provide new dimensions for the solution of productivity problems by application of photoelectric sensing. They combine PHOTOSWITCH quality, reliability and versatility into functional packages of reduced size, lower cost and increased operating features.

This control consists of a modulated visible LED source, high speed silicon photodetector and state-of-the-art thick film hybrid circuitry to operate a solid state power MOSFET output which can be used to interface with AC or DC power loads as well as with programmable controllers. The small size plus its functional flexibility makes the Series 6000 control ideally suited for space-limited applications on all types of machinery, robotics, conveyors, storage-retrieval systems and other automated assembly and material handling systems.

The **Type 42SRU Series 6000 REFLEX** control will operate reliably at distances up to 20 feet with a 3 inch retroreflective target and to proportionate distances with other types of retroreflective targets and tapes. See Typical Response Curve on page 2. The control is usable in high ambient light applications. Both **LIGHT OPERATE** and **DARK OPERATE** models are available.

Adjustable Sensitivity provides the ability to reduce sensitivity so the control can be used for applications requiring the detection of semi-transparent or translucent objects such as glass or plastic bottles, plate glass, plastic sheet and film when used with small diameter retro targets or retro tape. The externally adjustable sensitivity potentiometer is mounted above the cable entrance at the rear of the control. At the same location, a visible LED Alignment Indicator goes on, for **LIGHT OPERATE** models, to indicate that the control is on the retroreflective target. For **DARK OPERATE** models, the LED Alignment Indicator goes off when the control is on the retroreflective target. In addition, all type 42SRU Reflex controls are factory calibrated to assure no white paper response.

The functional electronics include **Synchronous Detection** circuitry which tends to restrict the control to operate only with its own pulsed LED source and thereby minimize interference from ambient noise. Also included in the circuit design is the assurance that there will be no false signal when power to the control is first applied.

Type 42SRU Series 6000 AC/DC models are designed to operate from supply voltages spanning the range of 20-132 VAC or DC or 20-264 VAC or DC, depending on model selected. These Reflex controls are three-wire devices consisting of two power leads and one solid state output switch lead — the other output switch lead being common with one power lead. See page 3 for **Wiring Diagrams**

The solid state output switch is a power MOSFET with a current handling capacity of 300 mA AC or DC for the 20-132 V controls and 150 mA for the 20-264 V scanners. Leakage current, with the switch open, is less than 1 mA for 120 V control and 1.5 mA for 240 V control. *However, as a precaution, please note that this device is not suitable to drive low level DC logic because there is a voltage drop of about 2 V across the switch regardless of the load.*

Both the MOSFET output and the driving circuitry are protected against destructive line transients by heavy-duty transient suppressors. The MOSFET output will handle inrush currents up to 10 times the continuous current rating. Please note that the MOSFET is not protected against severe overloads and direct short-circuits. Proper fusing is the customer's responsibility.

The electronic circuitry is fully encapsulated and sealed in epoxy in a corrosion-resistant, high impact NORYL housing and the optical system is fully gasketed to insure Nema 3, 4, 5, 12 and 13 ratings.

The **Type 42SRU Series 6000** is designed to function in difficult industrial environments. Its unique dimensional cross-section, 1/2" x 1", offers the best in mounting flexibility. It is round and threaded on the top and bottom and flat on the sides.

The control can be mounted in a nominal 1" diameter hole secured by two knurled hex mounting nuts supplied with the control. Or it can be mounted to a flat surface to take advantage of its 1/2" width. A series of bracket assemblies is available for single-hole or flat-side mounting with angular tilt, horizontal and vertical adjustments to assure installation flexibility. See Page 4 for mounting details.

Type 42SRU Series 6000 AC/DC controls are supplied with a 10 foot long UL Recognized Type SJTO cable that does not require enclosure in conduit. This represents considerable savings in installation cost.

OPERATING DISTANCE SELECTION

The Maximum operating Distance, shown in the specifications, is based on installing the control in a relatively clean environment. Experience tells us, however, that very few such ambient conditions exist in industry and the more normal industrial environment actually tends to cover the spectrum of classifications from moderately "dusty" to extremely "dirty".

For reliable service in "dusty" and "dirty" environments, greater Operating Margin (Excess Gain) may be required, therefore limiting the reliable Operating Distance of the control. The chart, in the adjacent column, is a typical response curve showing typical operating margins at varying distances.

At the extremes of minimum and maximum rated Operating Distances, rotating the retroreflector might improve the Operating Margin.

TYPICAL RESPONSE — 42 SRU-6000

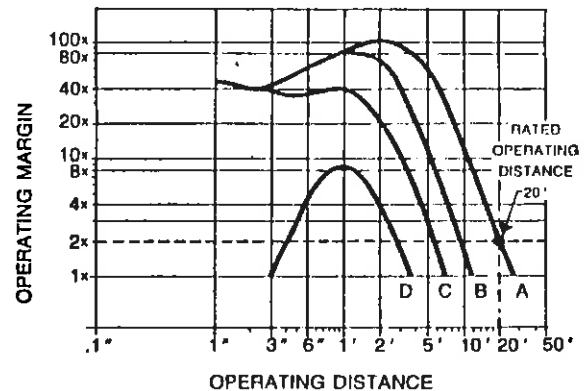

- A. 3" DIA., #92-39 RETROREFLECTOR
- B. 1.25" DIA., #92-46 RETROREFLECTOR
- C. 0.825" DIA., #92-47 RETROREFLECTOR
- D. 1" SQUARE 3M #7590 RETRO-TAPE

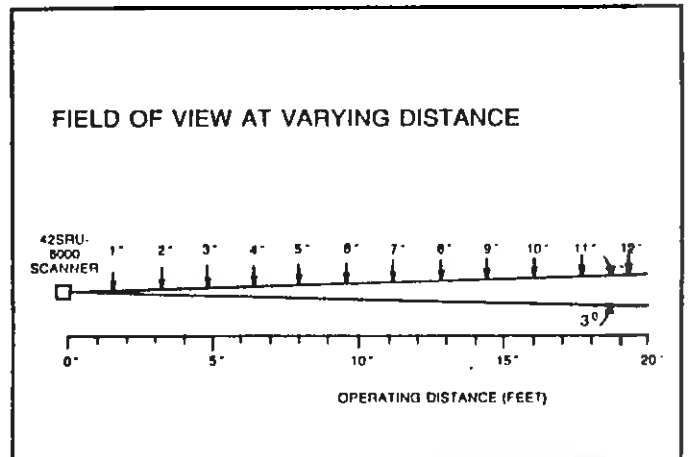

GENERAL

Type 42SRU Series 6200 AC/DC Polarized Beam Reflex mini-sized self-contained photoelectric controls were designed to solve a major application problem — that of Reflex controls responding to reflective objects and materials other than Retroreflective Targets. The Type 42SRU Polarized Beam Reflex control includes a unique optical filter system which will respond only to corner-cube type retroreflective targets. It will not respond to highly reflective surfaces such as stretch wrap, shrink wrap, mylar tape, metal straps, staples, retroreflective tape and even mirrors. This permits the use of easy to install, low cost Reflex controls instead of the more expensive Transmitted-Beam controls for applications where undesirable reflective surfaces are present.

This **AC/DC Polarized Beam Reflex** control consists of a modulated visible LED source, high speed silicon photodetector, filtered optics and state-of-the-art thick film hybrid circuitry to operate a solid state power MOSFET output which can be used to interface with power loads as well as with programmable controllers. The small size plus its functional flexibility makes the Series 6200 control ideally suited for space-limited applications on all types of machinery, robotics, conveyors, storage-retrieval systems and other automated assembly and material handling systems.

The **Type 42SRU Series 6200 Polarized Beam Reflex** control will operate reliably at distances up to 10 feet with a 3 inch corner-cube retroreflective target (#92-39) and to proportionate distances with other types of corner-cube retroreflective targets. See **Typical Response Curve on Page 2**. The control is usable in high ambient light applications. Both **LIGHT OPERATE** and **DARK OPERATE** models are available.

Adjustable Sensitivity provides the ability to reduce sensitivity so the control can be used for applications requiring the detection of transparent objects such as glass or plastic bottles, plate glass, plastic sheet and film. The externally adjustable sensitivity potentiometer is mounted above the cable entrance at the rear of the control. At the same location, a visible LED Alignment Indicator goes on, for **LIGHT OPERATE** models, to indicate that the control is on the retroreflective target. For **DARK OPERATE** models, the LED Alignment Indicator goes off when the control is on the retroreflective target. In addition, all models are factory calibrated to ensure neither white paper nor mirror response.

The functional electronics include **Synchronous Detection** circuitry which tends to restrict the control to operate only with its own pulsed LED source and thereby minimize interference from ambient noise. Also included in the circuit design is the assurance that there will be no false signal when power to the control is first applied.

Type 42SRU Series 6200 AC/DC models are designed to operate from supply voltages spanning the range of 20-132 VAC or DC or 20-264 VAC or DC, depending on the model selected. These Reflex controls are three-wire devices consisting of two power leads and one solid state output switch lead — the other output switch lead being common with one power lead. See **Page 3 for Wiring Diagrams**.

The solid state output switch is a power MOSFET with a current handling capacity of 300 mA AC or DC for the 20-132 V controls and 150 mA for the 20-264 V scanners. Leakage current with the switch open is less than 1 mA for 120 V control and 1.5 mA for 240 V control. *However, as a precaution, please note that this device is not suitable to drive low level DC logic because there is a voltage drop of about 2 V across the switch regardless of the load.*

Both the MOSFET output and the driving circuitry are protected against destructive line transients by heavy-duty transient suppressors. The MOSFET output will handle inrush currents up to 10 times the continuous current rating. Please note that the MOSFET is not protected against severe overloads and direct short-circuits. Proper fusing is the customer's responsibility.

The electronic circuitry is fully encapsulated and sealed in epoxy in a corrosion-resistant, high impact NORYL housing and the optical system is fully gasketed to insure Nema 3, 4, 5, 12 and 13 ratings.

The **Type 42SRU Series 6200** is designed to function in difficult industrial environments. Its unique dimensional cross-section, $\frac{1}{2}$ " x 1" offers the best in mounting flexibility. It is round and threaded on the top and bottom and flat on the sides. The control can be mounted in a nominal 1" diameter hole secured by two knurled hex mounting nuts supplied with the control. Or, it can be mounted to a flat surface to take advantage of its $\frac{1}{2}$ " width. A series of bracket assemblies is available for single-hole or flat-side mounting with angular tilt, horizontal and vertical adjustment for installation flexibility. See **page 4 for mounting details**.

Type 42SRU Series 6200 AC/DC controls are supplied with a 10 foot long UL Recognized Type SJTO cable that does not require enclosure in conduit. This represents considerable savings in installation cost.

OPERATING DISTANCE SELECTION

The Maximum operating Distance, shown in the specifications, is based on installing the control in a relatively clean environment. Experience tells us, however, that very few such ambient conditions exist in industry and the more normal industrial environment actually tends to cover the spectrum of classifications from moderately "dusty" to extremely "dirty".

For reliable service in "dusty" and "dirty" environments, greater Operating Margin (Excess Gain) may be required, therefore limiting the reliable Operating Distance of the control. The chart, in the adjacent column, is a typical response curve showing typical operating margins at varying distances.

At the extremes of minimum and maximum rated Operating Distances, rotating the retroreflector might improve the Operating Margin.

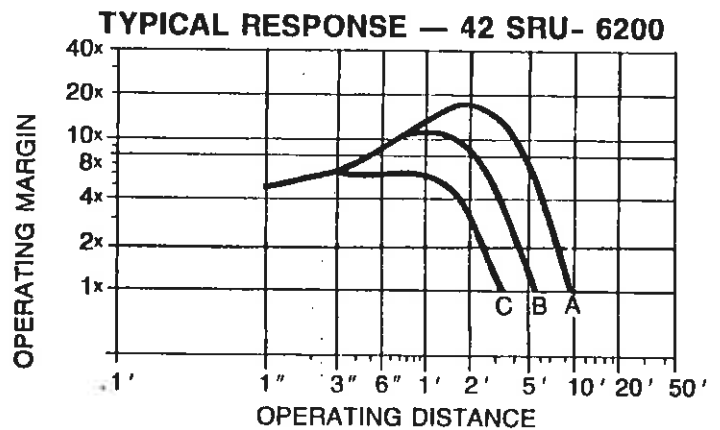

- A. 3" DIA., #92-39 RETROREFLECTOR
- B. 1.25" DIA., #92-46 RETROREFLECTOR
- C. 0.625" DIA., #92-47 RETROREFLECTOR

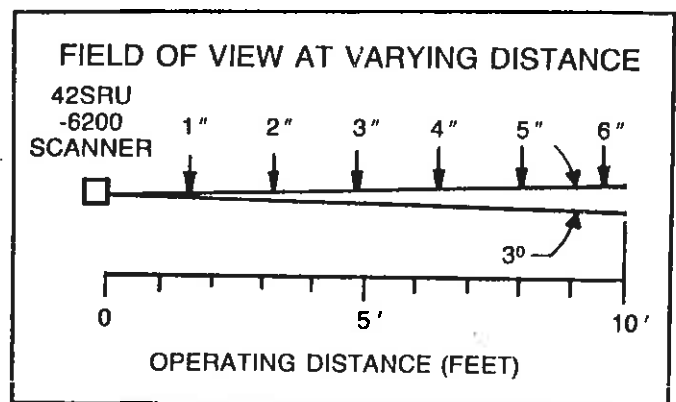

SPECIFICATIONS

Voltage Supply:

- Model 6004 (Light Operate).....20 to 132 VAC or DC
- Model 6005 (Dark Operate)20 to 132 VAC or DC
- Model 6006 (Light Operate).....20 to 264 VAC or DC
- Model 6007 (Dark Operate)20 to 264 VAC or DC

Power Consumption.....1.2 VA

Rated Load Current

- Models 6004 and 6005300 mA AC or DC
- Models 6006 and 6007150 mA AC or DC

Inrush Current10x Rated Load Current

Leakage Current (Off-State).....1 mA max. at 120 V
1.5 mA max. at 240 V

Response Time (includes output switch)

- Models 6004 and 600512 milliseconds for AC
5 milliseconds for DC
- Models 6006 and 600718 milliseconds for AC
10 milliseconds for DC

Transmitter LEDVisible RED, 660 nanometers

Turn-On Pulse SuppressionYES

Sensitivity Adjustment.....YES

Field of View3°

Ambient Temperature Range.....-40° F to +150° F
-40° C to + 65° C

Relative Humidity95%

Operating Environment:

Nema 3, 4, 5, 12 and 13 rated housing. Made of very high impact and chemically resistance NORYL.

Operating Distances:

- Maximum Operating Distance - 20 feet (6.1m)
- Minimum Operating Distance - 1 inch (2.54cm)
 - 3 inches (7.6cm) with tape

With 2 to 1 Operating Margin:

3" Diam #92-39	Retroreflective Targets		1" Square Retroreflective Tape (3M)			
	1.25 Diam #92-47	625 Diam #92-46	#3870	#7590	#7610	#7900
20 ft. (6.1m)	9 ft. (2.74m)	6 ft. (1.82m)	4.5 ft. (1.37m)	3 ft. (.91m)	5.5 ft. (1.68m)	3.5 ft. (1.07m)

Notes: See Typical Response Curve on Page 2

*Consult Factory

Cable:

10 feet UL Recognized Type SJTO, 3 conductor
 For extension beyond 10', order required footage of #59-296 cable.

ORDERING INSTRUCTIONS

1. Select Control

Voltage Supply	Light Operate	Dark Operate	Type and Model
20-132 V AC OR DC	X	X	42SRU-6004 42SRU-6005
20-264 V AC OR DC	X	X	42SRU-6006 42SRU-6007

2. Accessories (Optional):

- #60-2006 Single Hole Mounting Assembly
- #129-99 Hex Mounting Nuts (2) Package (included with control)
- #60-2007 Tilt Mounting Assembly
- #60-2008 Universal Mounting Assembly

MODELS 6004 AND 6005

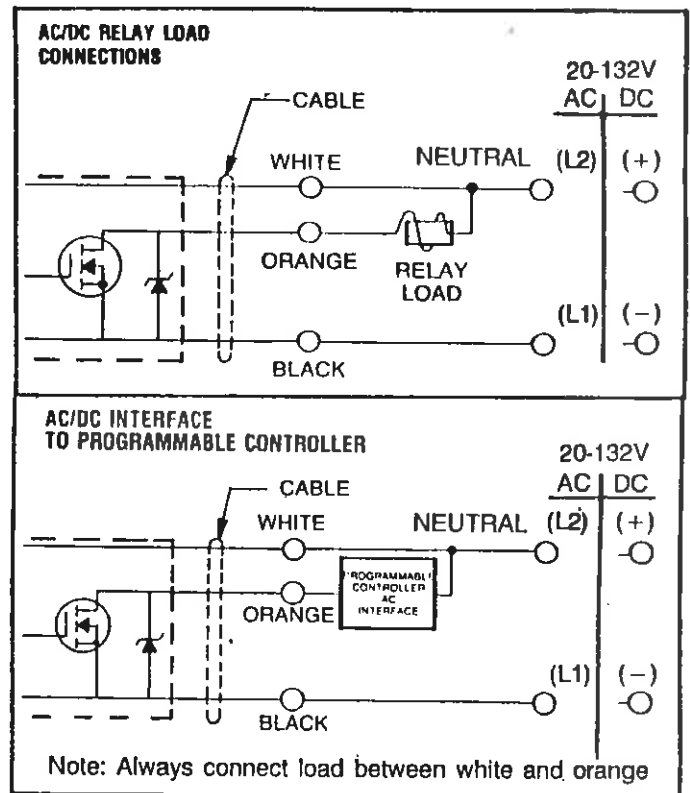

MODELS 6006 AND 6007

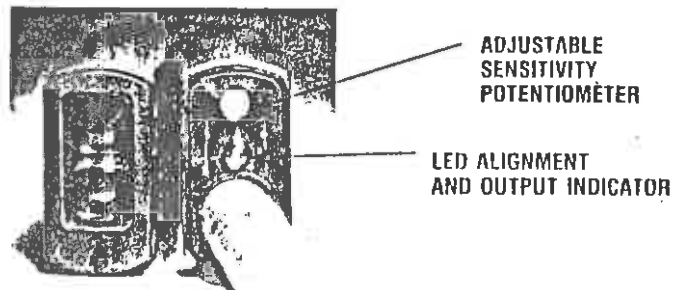
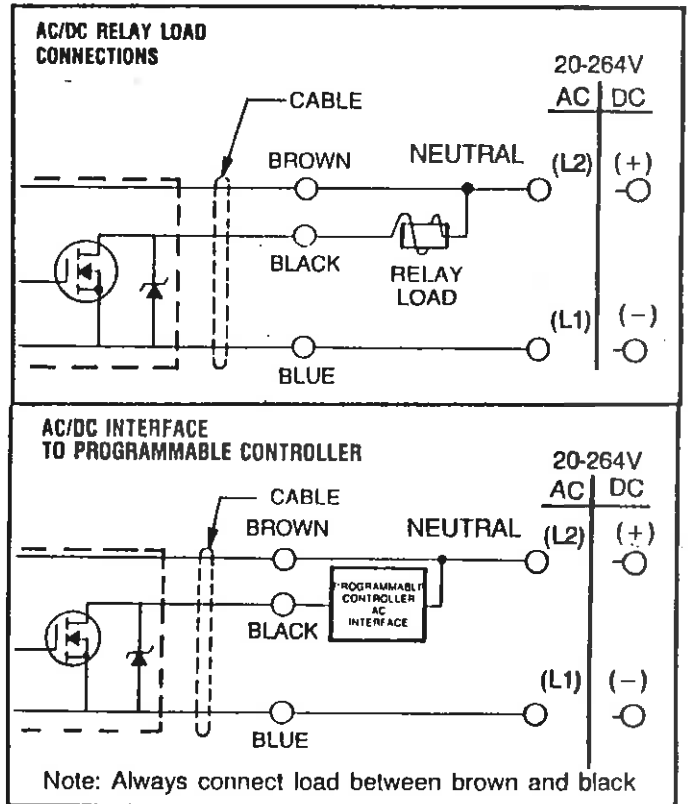

INSTALLATION

The Type 42SRU Series 6000 control must be mounted on a firm, stable surface or support. A mounting, which is subject to excessive vibration or shifting may cause intermittent operation. For installation convenience, we offer four mounting methods.

1. **Single Hole Mounting Assembly #60-2006.** A mounting bracket, with a nominal 1" hole, in which the 42SRU control is inserted and secured with the mounting nuts supplied with the control.
2. **Tilt Mounting Assembly #60-2007.** Includes stainless steel bracket and hardware to provide angular tilt adjustments.
3. **Universal Mounting Assembly #60-2008.** Includes stainless steel bracket and hardware to provide horizontal and vertical adjustments.
4. **Combination Assembly consisting of Tilt #60-2007 and Universal #60-2008 Mounting Accessories** to provide horizontal, vertical and angular tilt adjustments.

Wiring:

All external wiring should conform to The National Electric Code and applicable local codes. See Wiring Diagrams on Page 3 for external connections.

ALIGNMENT

Alignment of the Type 42SRU control, can be accomplished by visually sighting the control of the Retroreflector until the visible LED on the rear of the control glows (with LIGHT OPERATE model) or goes out (with DARK OPERATE model). To be certain that the beam is centered on the retroreflector, it is required to sweep the LED beam across the reflector in the horizontal plane and determine at what position the Alignment Indicator goes on and then goes off, set the beam halfway between both positions. Do the same in the vertical plane.

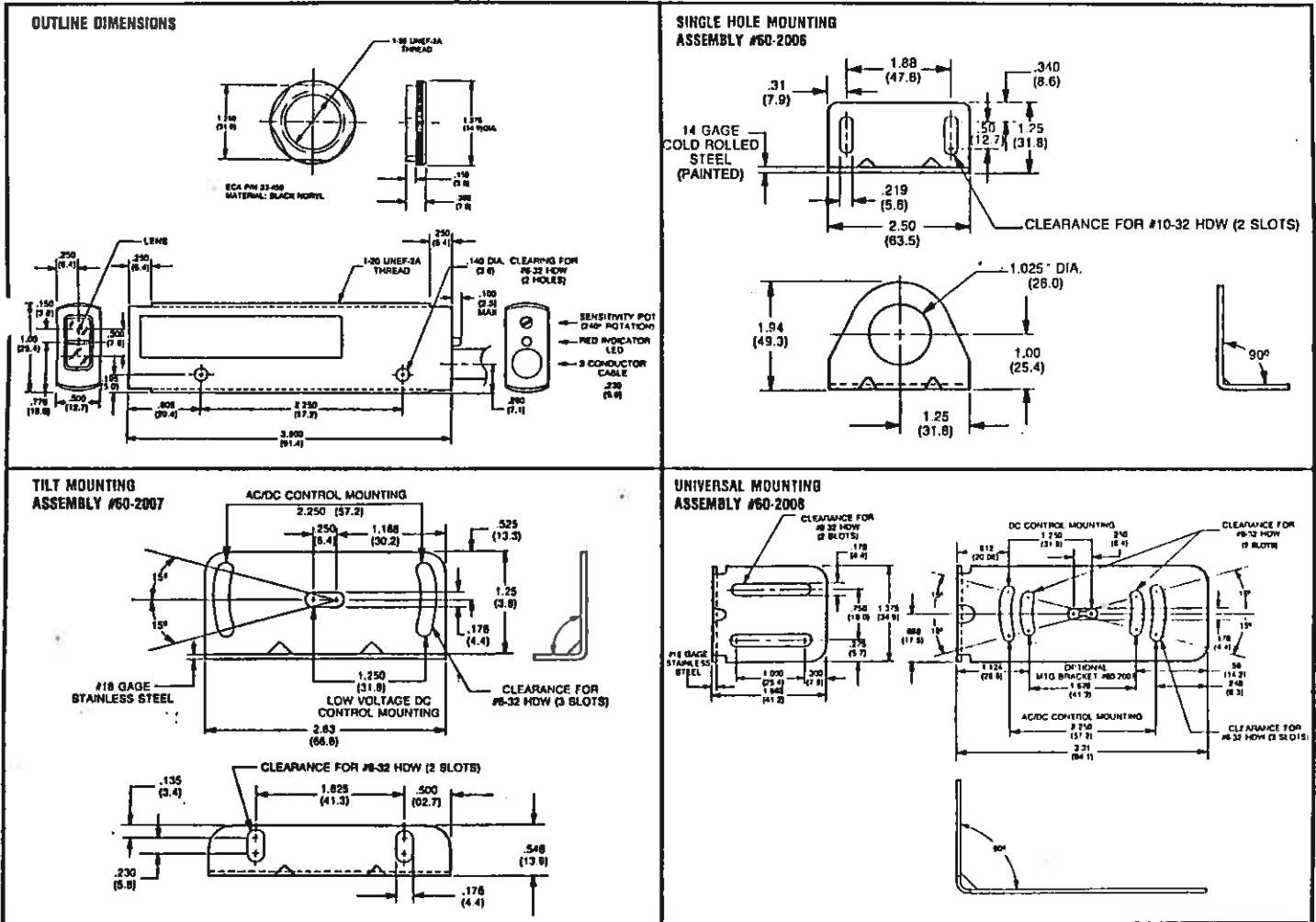

ELECTRONICS CORPORATION OF AMERICA PHOTOSWITCH DIVISION

265 Winter Street, Waltham, Massachusetts 02154 • Telephone: (617) 466-8000 • Telex: 92-1413

AREA OFFICES: Atlanta • Boston • Chicago • Cleveland • Houston • Los Angeles • New York • Philadelphia • San Francisco
 SUBSIDIARIES: ECA (Canada) LTD: Toronto, Montreal, Vancouver • ECA (Great Britain) LTD: London • ECA European Division: Brussels, Dusseldorf
 STOCKING DISTRIBUTORS: Located in major cities throughout the world.

TEMPERATURE SETTING OF CAL-STAT

Unless otherwise specified the temperature setting of CAL-STAT should be made in the following manner.

1. The open on temp. rise (O.T.R.) CAL-STAT will be adjusted to open at the set point and the close on temp. rise (C.T.R.) CAL-STAT will be adjusted to close at the set point.
2. Connect unit leads to heater with test light or other device suitable for determining contact position. (Contacts should be closed on O.T.R. units and open on C.T.R. units at this point).
3. Procedure for setting CAL-STAT:
 - 3.1 Install CAL-STAT in media to be controlled.
 - 3.2 Allow temp. of media to increase to 10° to 20° above required temp. by turning the adjusting screw CCW (Adjusting rate: approx. $90^{\circ}\text{F}/\text{rev.}$ for $5/8''$ CAL-STAT). Allow media to stabilize at this temp.
 - 3.3 Turn adjusting screw C.W. in small increments until desired control temp. is reached.
 - 3.4 CAL-STAT is now set.
NOTE: If over adjustment is made during step 3.3, re-start at step 3.2.
4. If readjustment is required, return to step 3.2 and repeat the procedure. Remember that all readjustments must be made by turning the adjusting screw C.W. to reach the desired set point.
5. Slow make-break CAL-STATS may be subject to a small amount of set point drift after the first few cycles under load. Due to relaxation of stresses and other factors, checking of set point and readjustment, if required, after approximately 100 cycles under load is recommended if very close control of set point is desired.

VULCAN ELECTRIC COMPANY VULCAN CAL-STAT®

This unit is calibrated for..... $^{\circ}\text{F}$. To increase setting turn screw CCW. Do not turn screw more than 7 revolutions in either direction from room temp. without checking set point. Disassembly of adjusting screw may render thermostat inoperative. Adjusting rate is approx. $90^{\circ}\text{F}/\text{revolution}$. Observe electric rating marked on unit.

In mounting, allow for expansion on both longitudinal and transverse axes. Our products are warranted to be free from defects in material and workmanship for a reasonable period of time, usually one year. Damage resulting from mishandling, improper application or injurious ambients cannot be covered by this warranty.

CONSULT FACTORY FOR SPECIAL
APPLICATIONS

Lubrication

REDUCERS MAY BE FILLED TO THE PROPER LEVEL AT THE FACTORY WITH AGMA No. 8 compounded oil. AFTER INSTALLATION OF THE BREATHER PLUG, UNIT IS READY FOR USE. Before installing breather plug, refer to instruction tag and determine proper position according to reducer mounting.

We recommend an initial oil change after 250 hours of operation, then every six months or every 2500 hours of service under Class I Service. If fluctuating temperatures, humid, dirty or corrosive environment, oil changes should be made more frequently. Frequency can be established by oil sample analysis.

KEEP YOUR OIL CLEAN

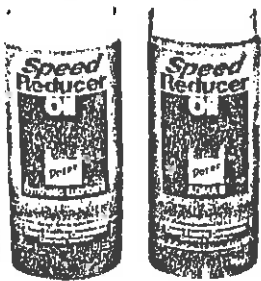

Doerr Electric replacement oil

To order oil, request:

Doerr part no. 00019001 — synthetic AGMA #7EP
(-40°F to 150°F)

Doerr part no. 00019101 — AGMA #8 (50°F to 125°F)

Oil is packed 12 one quart bottles per carton, minimum ship one carton.
Contact DEC Service Dept. for order information.

OIL CAPACITIES*

UNIT TYPE	UNIT SERIES				
	133	173	200	262	323
Worm Over	14	20	27	49	84
Worm Under	17	22	28	49	73
Vertical Output	10	15	20	37	63
"J" Mount	13	18	23	38	63

*Capacities in approximate ounces. On double reduction units determine capacity of both primary and secondary reducers.

OIL LEVELS*

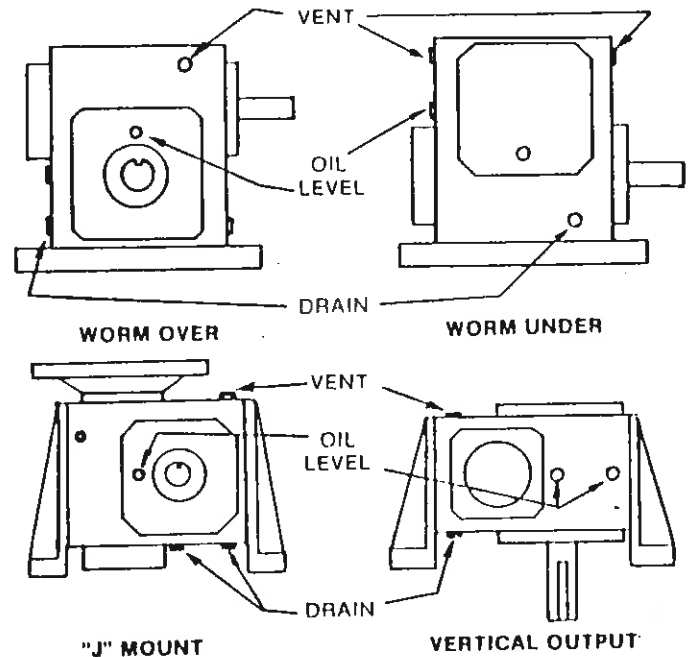

*On double reduction units fill and vent each unit to levels shown.

Motor dimensions

TEFC P/M motor

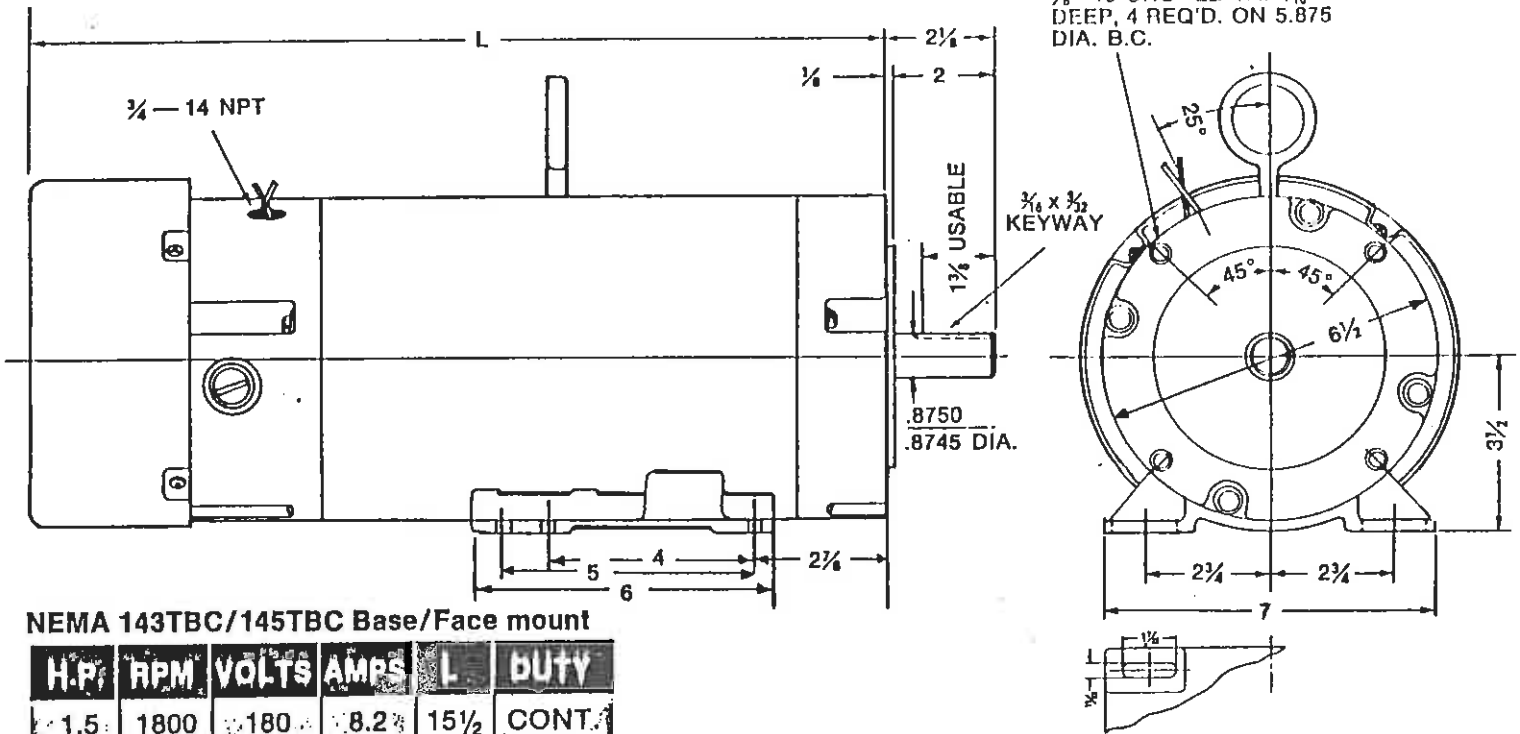

NEMA 143TBC/145TBC Base/Face mount

H.P.	RPM	VOLTS	AMPS	L	DUTY
1.5	1800	180	8.2	15 1/2	CONT.
2	1800	180	11.6	16 1/2	CONT.

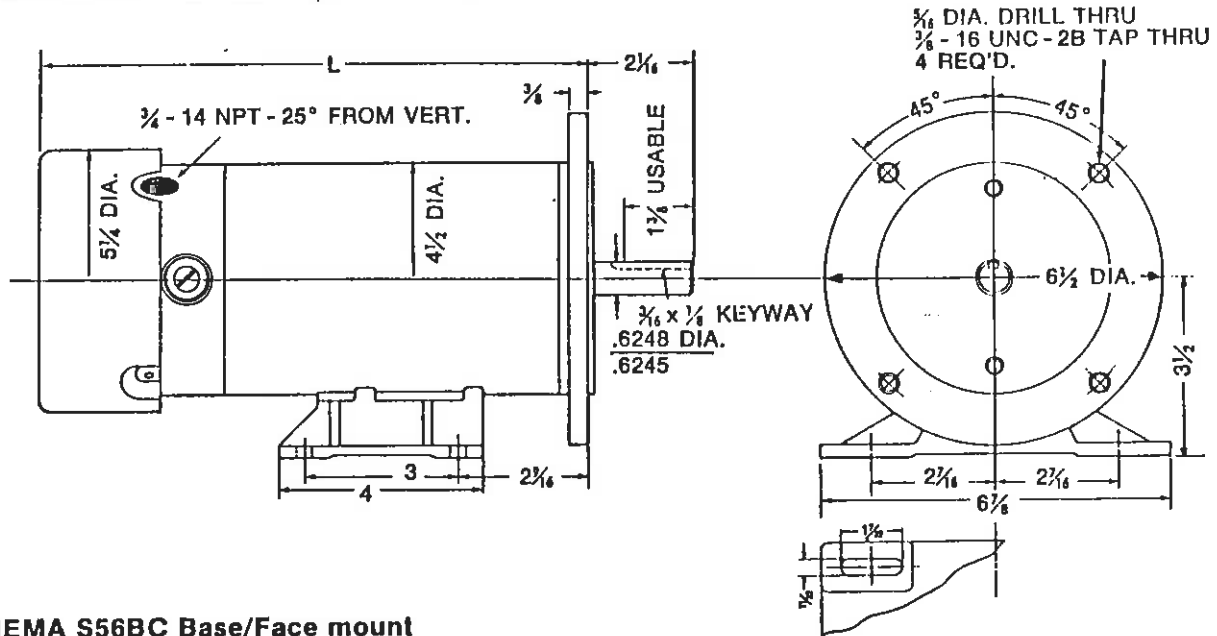

NEMA S56BC Base/Face mount

180 V.

H.P.	RPM	VOLTS	AMPS	L	DUTY
1/2	1725	180	2.8	10 3/4	CONT.
3/4	1725	180	3.5	12 3/4	CONT.
1	1725	180	5.35	14 3/4	CONT.

90 V.

H.P.	RPM	VOLTS	AMPS	L	DUTY
1/2	1725	90	5.35	10 3/4	CONT.
3/4	1725	90	8.1	12 3/4	CONT.
1	1725	90	10.6	14 3/4	CONT.

TEMPERATURE SETTING OF CAL-STAT

Unless otherwise specified the temperature setting of CAL-STAT should be made in the following manner.

1. The open on temp. rise (O.T.R.) CAL-STAT will be adjusted to open at the set point and the close on temp. rise (C.T.R.) CAL-STAT will be adjusted to close at the set point.
2. Connect unit leads to heater with test light or other device suitable for determining contact position. (Contacts should be closed on O.T.R. units and open on C.T.R. units at this point).
3. Procedure for setting CAL-STAT:
 - 3.1 Install CAL-STAT in media to be controlled.
 - 3.2 Allow temp. of media to increase to 10° to 20° above required temp. by turning the adjusting screw CCW (Adjusting rate: approx. 90°F/rev. for 5/8" CAL-STAT). Allow media to stabilize at this temp.
 - 3.3 Turn adjusting screw C.W. in small increments until desired control temp. is reached.
 - 3.4 CAL-STAT is now set.
NOTE: If over adjustment is made during step 3.3, re-start at step 3.2.
4. If readjustment is required, return to step 3.2 and repeat the procedure. Remember that all readjustments must be made by turning the adjusting screw C.W. to reach the desired set point.
5. Slow make-break CAL-STATS may be subject to a small amount of set point drift after the first few cycles under load. Due to relaxation of stresses and other factors, checking of set point and readjustment, if required, after approximately 100 cycles under load is recommended if very close control of set point is desired.

VULCAN ELECTRIC COMPANY VULCAN CAL-STAT®

This unit is calibrated for.....°F. To increase setting turn screw CCW. Do not turn screw more than 7 revolutions in either direction from room temp. without checking set point. Disassembly of adjusting screw may render thermostat inoperative. Adjusting rate is approx. 90°F./revolution. Observe electric rating marked on unit.

In mounting, allow for expansion on both longitudinal and transverse axes. Our products are warranted to be free from defects in material and workmanship for a reasonable period of time, usually one year. Damage resulting from mishandling, improper application or injurious ambients cannot be covered by this warranty.

CONSULT FACTORY FOR SPECIAL
APPLICATIONS

Electrical Boards' Chart for ORION Stretchwrappers

	168-4	168-A	236	336	750+	750M-240y	850M	850C	155-3A
MLH 44 Processor	X		X		X				
MLH 44	X		X		X				X
MLH 55		X		X			X		X
MLH 66		X		X			X		X
MLH 77		X							X
PA 33	X			X	X				
FA 33	X			X		X		X	
MA 33	X			X		X		X	
MA 44	X			X	X			X	
MA 55	X			X			X	X	

INSTALLATION INSTRUCTIONS FOR ANTI-VIBRATION MOUNTING

PART IDENTIFICATION

- ① SERIES 6000 UNIT
- ② PLASTIC NUTS (33-450)
- ③ VIBRATION MOUNT (16-153)
- ④ SLIP PAD (89-51)

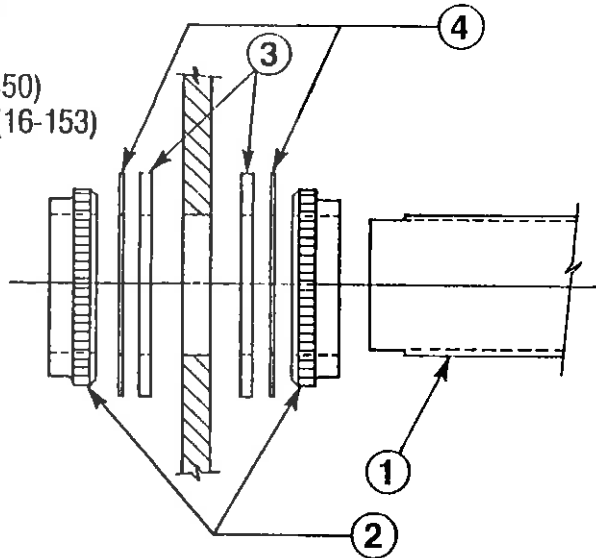

133-440

6000 SERIES CONTROLS FEATURE INTERFERENCE AVOIDANCE BY CHOICE OF FREQUENCIES

6000 Series Controls are supplied to operate at two different frequency ranges, permitting controls to be mounted close to each other without generating interfering signals.

Units in one frequency range are marked with a dot (•) next to date code. Units in the other frequency range have no dot.

Accordingly, when two Series 6000 Controls are mounted close together and/or face each other, select controls so that one is marked with a dot (•) and the other has no dot.

133-439

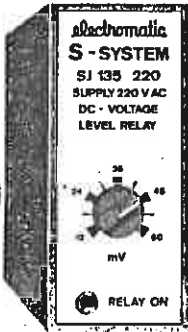

SJ 135



- * DC voltage metering relay with absolute scale.
- * Measuring range: 12 mV - 500 VDC, divided into 10 ranges.
- * Knob-adjustable set point.
- * Latching at set level possible.
- * 10 A SPDT output relay.
- * LED-indication: relay on.
- * AC or DC power supply.

SJ 135 = 11-pin circular plug

SPECIFICATIONS

The common technical data

Measuring ranges

Ranges	Internal resistance	Max. voltage	YYYYY
12 - 60 mV	100 Ω	1 V	60 mV
30 - 150 mV	150 Ω	2 V	150 mV
0.2 - 1 V	1 KΩ	10 V	1 V
1 - 5 V	3 KΩ	30 V	5 V
2 - 10 V	10 KΩ	50 V	10 V
4 - 20 V	20 KΩ	100 V	20 V
10 - 50 V	51 KΩ	150 V	50 V
30 - 150 V	150 KΩ	350 V	150 V
60 - 300 V	300 KΩ	500 V	300 V
100 - 500 V	510 KΩ	600 V	500 V

Hysteresis

Approx. 10%.
The hysteresis can be extended to approx. 75% by connecting a suitable resistor between pins 8 and 9.
Resistor limits are 470 KΩ/3 KΩ (0.25 W).
The hysteresis increases by decreasing resistance.

Latching

By interconnecting pins 8 and 9 the relay will latch at set level until either the power supply or the interconnection is interrupted.

Ordering key

11-pin circular plug.
SJ 135 XXXYYYYY = 10 A SPDT

XXX = power supply

024 = 20-28 VAC

115 = 95-135 VAC

230 = 195-265 VAC

724 = 20-28 VDC

YYYYY: See measuring ranges.

Accessories

Bases.

Hold down spring.

Mounting rack.

Base covers.

Front mounting bezel.

WIRING DIAGRAMS

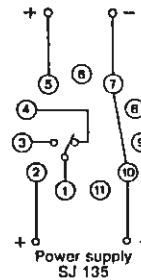
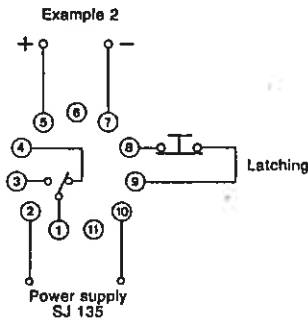
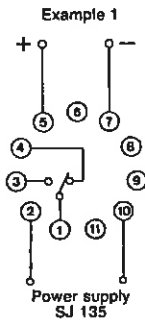

Note:
Internal connection between pins 7 and 10 at DC power supply. No current is to pass through this internal connection.

MODE OF OPERATION

Example 1

DC voltage metering. (AC power supply).

The relay will operate when the actual voltage equals the set value. The relay releases when the voltage drops min. 10% below the set value (see hysteresis) or when the power supply is interrupted.

Example 2

DC voltage metering. Latching. (AC power supply).

The relay will operate and remain in operating position when the actual voltage equals the set value. Provided that the voltage has dropped min. 10% below the set value (see hysteresis), the relay will release when the interconnection between pins 8 and 9 is interrupted. The relay also releases when the power supply is interrupted.

OPERATION DIAGRAM

Example 1

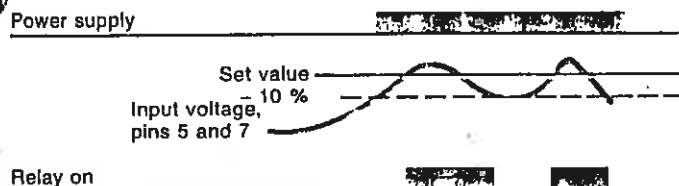

Example 2

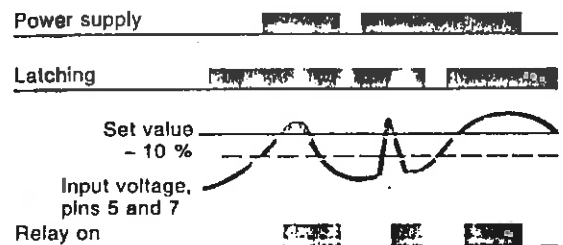



MAINTENANCE INSTRUCTIONS

STANDARD REDUCERS SERIES 133, 175, 206, 262, 325

INDEX

	Page
Introduction	1
Equipment Required	1
General Instructions	1
Housings	1
Seals	1
To Change Output Shaft Direction	1
Unit Disassembly, Parts Service, and Reassembly	1
Disassembly	1
Low Speed Shaft Removal	1
High Speed Shaft Removal	1, 2
Parts Service	2
Housing	2
Seal Cages and End Cover	2
Air Vent	2
Seals	2, 3
Bearings	3
Worm Gear and Shaft	3
Unit Reassembly	4
High Speed Shaft Assembly	4
Low Speed Shaft Assembly	4
Preventive Maintenance	6
Stored and Inactive Units	6
Parts Ordering Instructions	6
Exploded Views	7, 8, 9
Parts List	9
Warranty	Back Cover

MAINTENANCE INSTRUCTIONS FOR STANDARD REDUCERS

Series 133, 175, 206, 262 and 325

INTRODUCTION

The following instructions apply to standard Worm Gear Reducers. When ordering parts or requesting information specify all information stamped on the reducer nameplate. The nameplate will also identify the type of lubricant to be used.

EQUIPMENT REQUIRED

In addition to standard mechanic's tools, the following equipment is required: arbor press, wheel puller, torque wrench, dial indicator, seal driver, bluing, Permatex No. 2 and Permatex No. 3, snap ring pliers for internal and external rings.

GENERAL INSTRUCTIONS

Housings — Clean external surfaces of reducer before removing seal cages and end covers to prevent dirt from falling into the unit. Record mounting dimensions of accessories for reference when reassembling. If it is necessary to remove the reducer from its operating area, disconnect all connected equipment and lift reducer from its foundation.

Seals — Replacement of all seals is recommended when a unit is disassembled. However, if seals are not to be replaced, protect seal life by wrapping shaft with thin, strong paper coated with oil or grease before removing or replacing seal case assembly. Clean the shaft but do not use any abrasive material on the shaft surface polished by the seal.

CAUTION

If the reducer is painted, extreme care should be taken to mask the shaft extensions and rubber surface of the seals. Paint on the shaft adjacent to the seal or on the seal lip will cause oil leakage.

TO CHANGE OUTPUT SHAFT DIRECTION

To change the hand of a unit from left hand to right hand, or vice versa, the following instructions apply:

1. Remove drain plug and drain oil from unit.
2. Remove end cover and seal cage cap screws; then while supporting output shaft remove end cover and shims from the unit.
3. Remove output shaft and seal cage together from extension side.

NOTE: Keep shims with their respective seal cage and end cover.

4. Insert seal cage, shims and sub-assembly into the housing from the side opposite from which they were removed. Insert seal cage cap screws and tighten with light pressure.
5. Assemble end cover and shims. Insert end cover cap screws and tighten with light pressure.
6. Turn high speed shaft in both directions to see that gear train is running freely.
7. Cross tighten seal cage and end cover cap screws to torques listed in Table 1.

TABLE 1. CAPSCREW TIGHTENING TORQUE

Capscrew Diameter	1/4 - 20 UNC	5/16 - 18 UNC	3/8 - 16 UNC
Torque (in. lbs.) Dry	96	204	360

UNIT DISASSEMBLY, PARTS SERVICE, AND ASSEMBLY

Disassembly:

1. Remove drain plug and drain oil from unit.
2. Low speed shaft (gear shaft) removal:
 - A. Remove end cover and seal cage cap screws.
 - B. With a firm hold on the output extension remove end cover and shims.
 - C. Carefully slide output shaft assembly and seal cage out extension side.
 - D. Slide seal cage off low speed shaft using caution to prevent damage to seal lips.
 - E. Wire or tie the shims to their mating end cover and seal cages. They will be available for reference when assembling the unit.
3. High speed shaft (worm shaft) removal:
 - A. Position unit with input shaft down. With a small chisel make a groove in the stamped steel cover opposite the shaft extension. Pry cover off.

- B. Remove internal snap ring from housing bore.
- C. Reposition the housing with the worm shaft horizontal. Using a plastic hammer gently tap on the end of the shaft extension to feed worm shaft assembly through housing and out.

Parts Service:

- 1. **Housing** — Clean inside of housing with kerosene or solvent and then dry.
- 2. **Seal cages and end cover** — Remove dirt from joint faces, wipe clean and dry.
- 3. **Air vent** — Wash in kerosene, blow clean and dry.
- 4. **Seals** — To replace seals without dismantling reducer refer to steps C through F below. To replace seals when the entire reducer is dismantled and coupling hubs, sprockets, pulleys, pinions, keys, etc. have been removed the following instructions apply:

NOTE: Replacement of all seals is recommended when a unit is disassembled.

Caution

New seals will leak if the seal lips or if seal's rubbing surface on the shaft has been altered. Protect seal lips at all times. Clean the shaft but do not use any abrasive material on the shaft surface polished by the seal.

- A. Block up seal cages and press or drive out seal.
- B. Remove old sealing compound from seal seat in cage if it is present. If a seal with rubber coating on the outside diameter is used, no Permatex is necessary. If no rubber coating is on seal outside diameter, coat seal cage bore with Permatex No. 3 or equivalent immediately before assembly.
To prevent possible damage to seal lips, do not reassemble seals until high speed and low speed shafts have been reassembled to the housing. Then see steps E and F below.
- C. See Figures 1 through 4—To replace seals without dismantling reducer, proceed as follows:

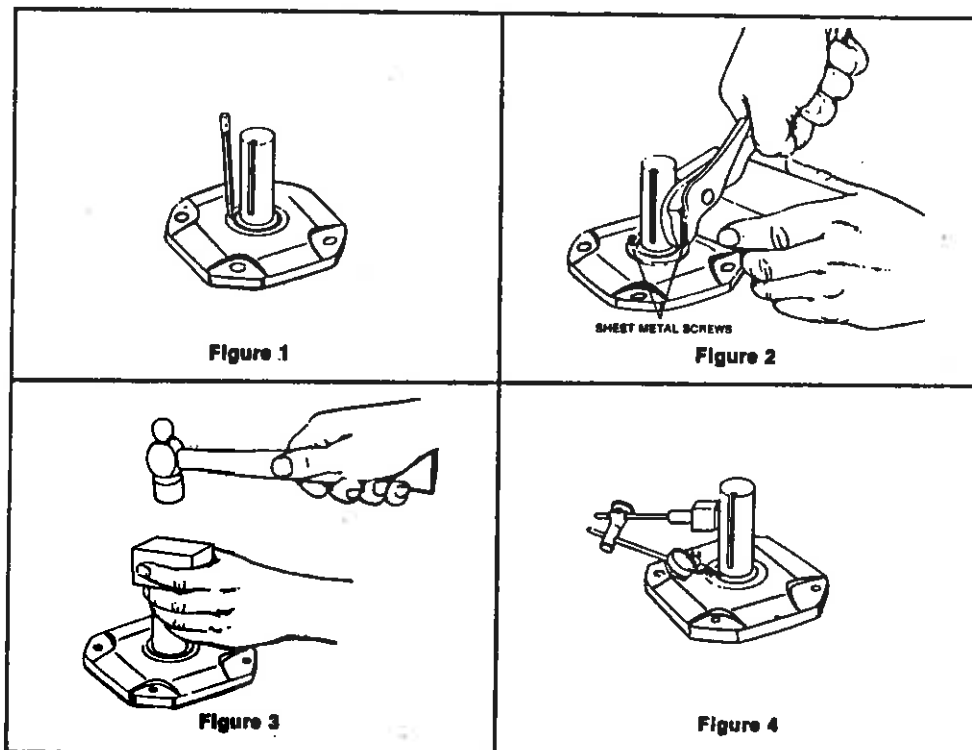

Caution

Do not damage shaft; new seals will leak if seal contacting surface is marred. Use punch and place two or more holes in steel casing of seal, Figure 1. (The steel casing may be rubber coated) Insert sheet metal screws, leaving the heads sufficiently exposed so they can be pried up or grasped with pliers, Figure 2. Do not drill holes because chips may get into the unit.

- D. Work seal loose. Be careful to keep all metal or dirt particles from entering unit. Remove old sealing compound from seal seat if it is present. Also remove burrs and sharp edges from shaft. Clean with rag moistened with solvent. Do not use abrasive material on shaft seal contacting surface.

Caution

- E. Protect seal lips when handling; seal leakage will result if these are damaged. If a seal with rubber coating on the outside diameter (O.D.) is used, no Permatex is necessary. If no rubber coating is on seal O.D., coat seal cage bore with Permatex No. 3 or equivalent. Coat seal lips with oil and carefully work seal into position. Before sliding seal into position, protect seal lips from shaft keyway edges by wrapping shaft with thin, strong paper coated with oil. Position garter spring toward the inside of the unit. Place a square faced pipe or tube against the seal O.D. and drive or press seal until fully seated as shown in Figure 3. Do not strike seal directly.

- F. For best performance, seat the seal square with shaft within .005" at 180°. Check with dial indicator as shown in Figure 4, Page 2, or with a straight edge and feelers, or square and feelers. To straighten a cocked seal, place tubing over the seal and tap the tube lightly at a point diametrically opposite the low point on the seal. DO NOT strike seal directly.

5. Bearings —

- A. Wash all bearings in clean kerosene and then dry.
B. Inspect bearings carefully and replace those that are worn or questionable.
NOTE: Replacement of all bearings is recommended.
C. Use a wheel puller or press to remove worm shaft bearings. Apply force to inner race only — not to cage or outer race.
D. Use a wheel puller or press to remove output bearing inner races.
E. New seal cages and end covers must be used when replacing output bearings. Output bearing outer races must be pressed in square and seated completely.
F. To replace output bearing inner races and all input bearings, heat bearings in an oil bath or oven to maximum of 290 degrees F (143 degrees C). Slide high speed shaft bearings onto the oiled shaft until seated against the shoulder or snap ring of the shaft. Slide low speed shaft bearings onto the oiled shaft against the gear spacer.
G. Thoroughly coat all bearings with lubricating oil.

6. Worm, gear and shafts

- A. Worm and high speed shaft—since all worms are integral with the high speed shaft, any wear or damage to the worm will necessitate replacing both.
B. Press shaft out of bronze worm gear. To reassemble gear and low speed shaft, freeze shaft or heat gear. Do not exceed 200 degrees F (93 degrees C). Insert key into shaft keyway and press shaft into oiled gear bore. The short hub of the gear must be assembled toward snap ring on the shaft.
NOTE: It is advisable to replace both the worm and worm gear should either of the assemblies require replacement.

Unit Reassembly:

1. Preliminary

- A. Check to see that all worn parts have been replaced, gear and bearings coated with oil and all parts cleaned. Remove all foreign matter from unit feet. The feet must be flat and square with each other.
- B. Before starting to reassemble reducer, add old shims or replace with new shims of equal thickness.

2. High Speed Shaft (Worm Shaft) Assembly

- A. Lubricate bearing bores of housing and insert high speed shaft sub-assembly from opposite extension end into housing until seated against shoulder in bore. Tap the end of the shaft lightly with a plastic hammer to feed bearings through bores.
- B. Lock high speed sub-assembly in housing bore with lock ring.
- C. Coat outside diameter of stamped steel end cover with Permatex No. 2 and press into high speed bore opposite extension end until flush with housing. If steel endcover is rubber coated then no Permatex is necessary.

3. Low Speed Shaft (Gear Shaft) Assembly

- A. Determine output shaft direction.
- B. Assemble low speed shaft assembly, seal cage, and end cover with shims on both seal cage and end cover. Torque cap screws to torques listed in Table 1. Rotate the input shaft to seat output bearings.
- C. Moving the shaft back and forth by hand, check axial float with dial indicator as shown in Figure 5. Axial float must be .0005-.003 with .0005 being the absolute minimum. Do not preload bearings. If the axial float is not as specified add or subtract required shims under end cover.

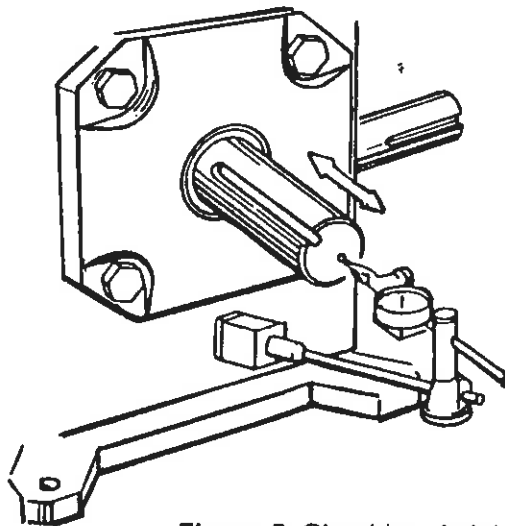

Figure 5 Checking Axial Float

- D. Remove output shaft with seal cage and apply bluing to entire worm thread. Worm thread must be clean of oil. Reassemble output shaft and seal cage with output key facing up.
- E. Use a rag to apply hand pressure to the output shaft and rotate the high speed shaft until output key is down. Return output shaft to original position by reversing rotation. Remove output shaft and seal cage to inspect contact. Compare with Figure 6. If contact is not correct move assembly in the direction shown in Figure 6 by adding shims to the side to which the arrow points after removing them from the opposite side. Repeat steps D and E until contact pattern is correct.
- F. Recheck axial float with dial indicator.
- G. When contact pattern is correct tighten seal cage and end cover cap screws to torques listed in Table 1 page 1.

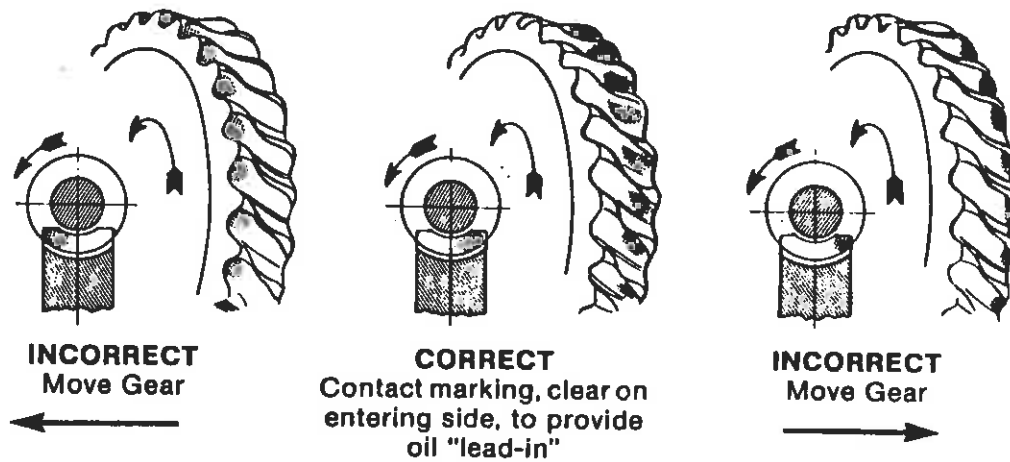

Figure 6 Gear Contact Pattern

4. **Seals** — To reassemble seals to unit, see Parts Service Steps 4E and 4F, page 3.

5. **Motorized Coupling Adapter**

Certain mounting dimensions should be adhered to when removing motor and coupling assembly for service. When ordering replacement coupling halves (metal gear), specify correct bore diameter. See Table 2 for mounting dimensions and available bore sizes.

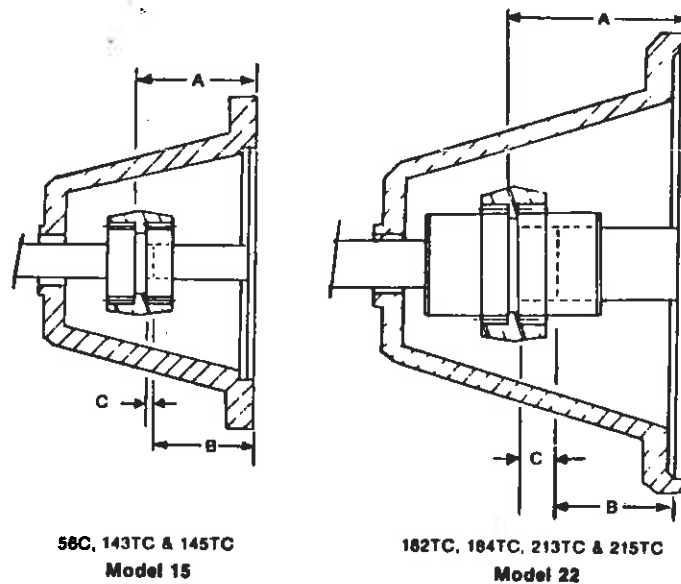

Figure 7 Motorized Coupling Adaptor

TABLE 2. COUPLING ADAPTOR DATA

"C" COUPLING MOUNTING DATA

N.E.M.A. Frame No.	Mounting Dimensions		
	Reducer A ± 1/64	Motor B ± 1/64	C
56C	2 5/16	2 1/16	1/16
143TC	2 5/16	2 1/8	—
145TC	2 5/16	2 1/8	—
182TC	3 5/16	2 5/8	1/2
184TC	3 5/16	2 5/8	1/2
213TC	3 5/16	3 1/8	—
215TC	3 5/16	3 1/8	—

BORE SIZES AVAILABLE

MODEL 15		MODEL 22	
Bore	Kwy.	Bore	Kwy.
.500	None	—	—
.500	1/8 x 1/16	—	—
.625	3/16 x 3/32	.625	3/16 x 3/32
.750	3/16 x 3/32	.750	3/16 x 3/32
.875	3/16 x 3/32	.875	3/16 x 3/32
—	—	1.125	1/4 x 1/8
—	—	1.375	3/16 x 3/32

6. Final Inspection

- A. Turn gear train over by hand as a final check.
- B. Re-install reducer and accessories.

CAUTION: Discard motor key. Use only special key provided with reducer. Failure to use special key will make assembly impossible.

- C. Fill reducer with the recommended oil to proper level. See Fig. 8 for standard oil levels. (Type of oil recommended — see nameplate).
- D. Spin test for three minutes and check for noise, leakage, and rapid temperature rise.

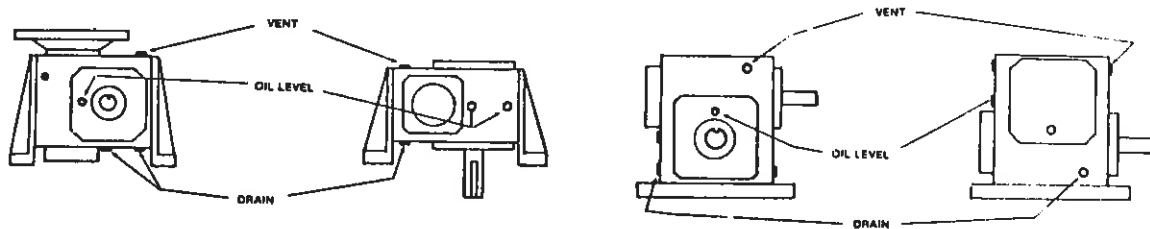

Figure 8 Standard Oil Levels

PREVENTATIVE MAINTENANCE

- A. After first week check all external cap screws and plugs for tightness.
- B. Periodically, check oil level when gears are at rest. Add oil if needed. Do not fill above mark indicated by level because leakage and overheating may occur.
- C. Oil changes — For normal operating conditions, change oil every six months or 2500 hours, whichever occurs first. Also if the unit is operated in an area where temperatures vary with the season, change the oil viscosity to suit the temperature. Most lubricant suppliers can test oil periodically and recommend economical oil change schedules.

CAUTION

See nameplate for type of lubricant to be used.

STORED AND INACTIVE UNITS

1. Each unit is shipped with oil that will protect parts against rust for a period of 4 months in an outdoor shelter or 12 months in a dry building after shipment from the factory. Indoor dry storage is recommended.
2. If a unit is to be stored or is to be inactive after installation beyond the above periods, fill the unit completely with oil.

CAUTION

Before starting a stored unit or re-starting an inactive unit, the oil level should be returned to the proper value as indicated by the oil level.

PARTS ORDERING INSTRUCTIONS

When ordering replacement parts first locate the exploded view that corresponds to your Doerr Electric gear reducer. Then determine which parts must be ordered. To order the parts, please provide the following:

1. Complete Model Number (Nameplate)
2. Item Number (Exploded view and parts list)
3. Part Description (Parts list)

Note that one parts list covers all five exploded views. Although a single item number may refer to the same part on all five exploded views, it is incorrect to assume that these parts are interchangeable. They are not. Therefore, it is imperative that items 1 through 3 above be provided when ordering your parts.

Failure to provide this information will only slow or prevent the processing of your order.

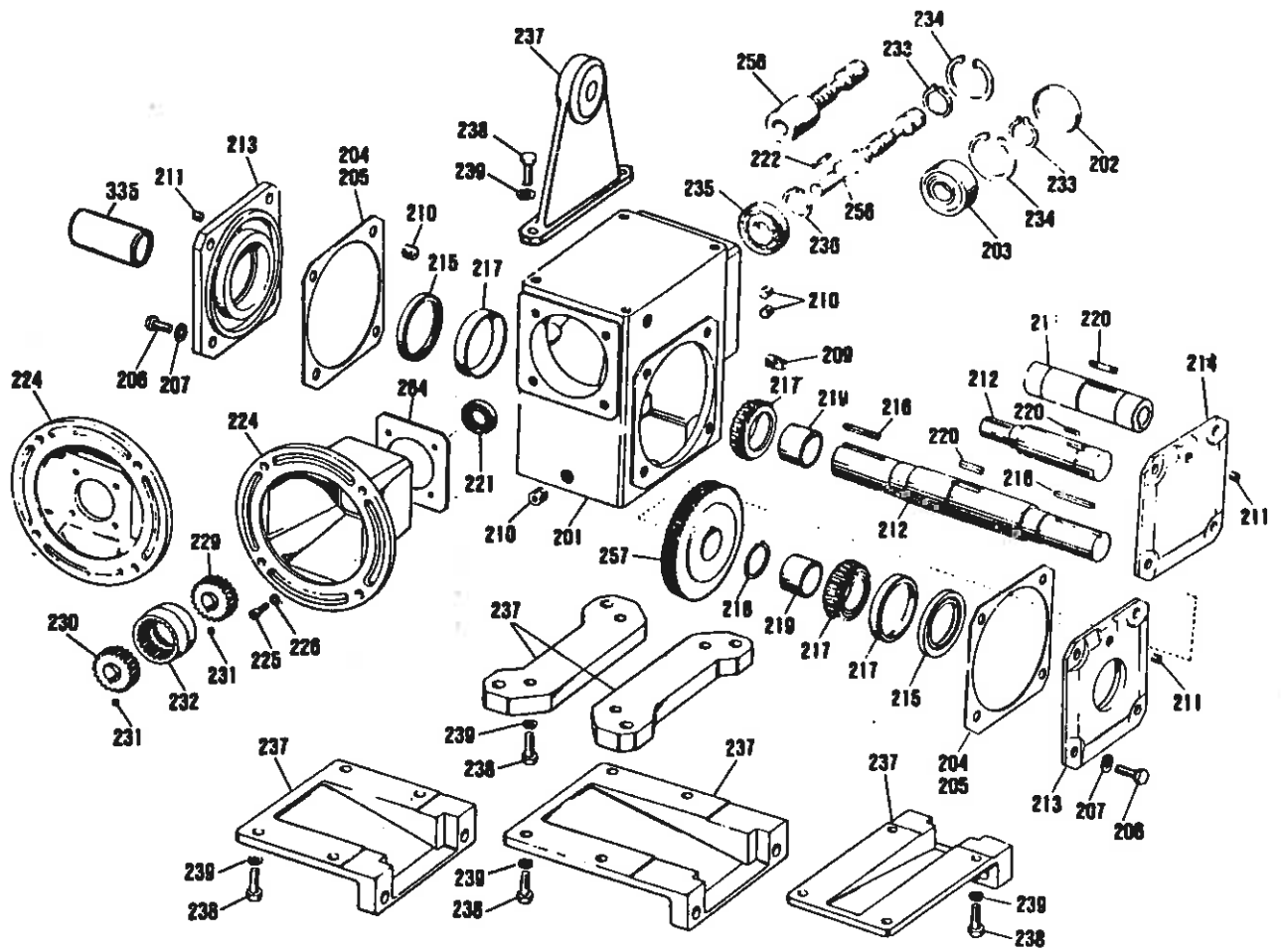

Single Reduction Unit 133, 175, 206 Series

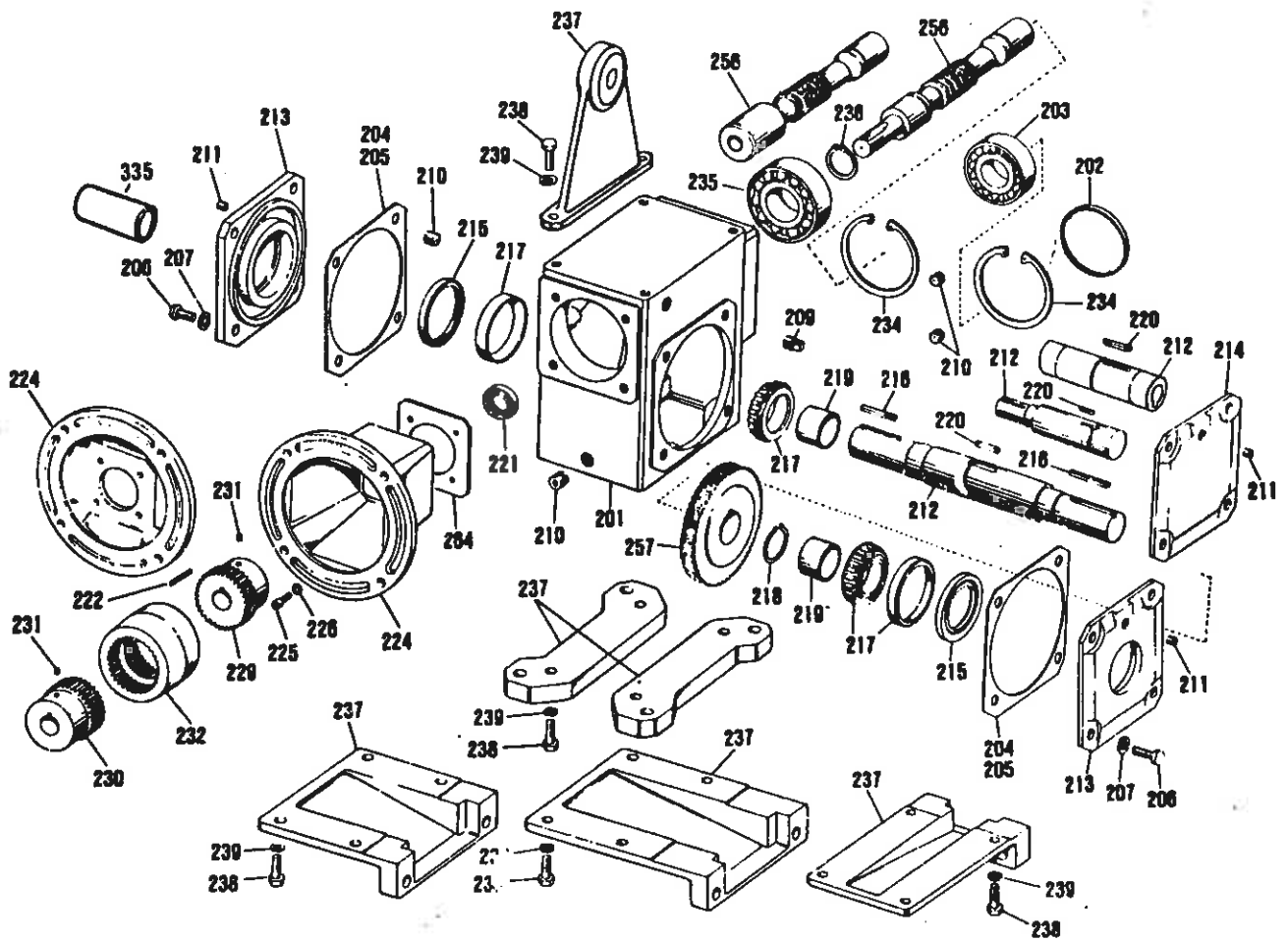

Single Reduction Unit 262, 325 Series

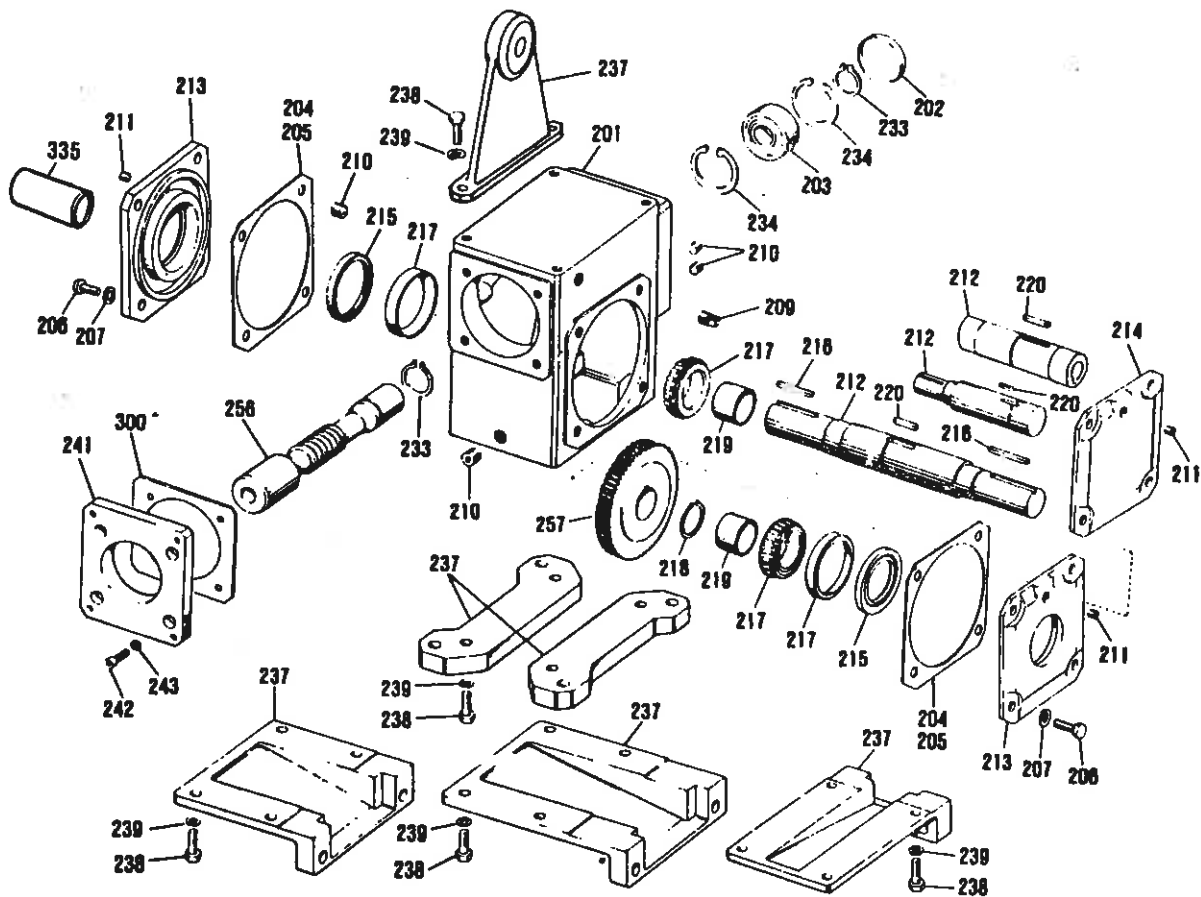

Double Reduction Secondary Unit 133, 175, 206 Series

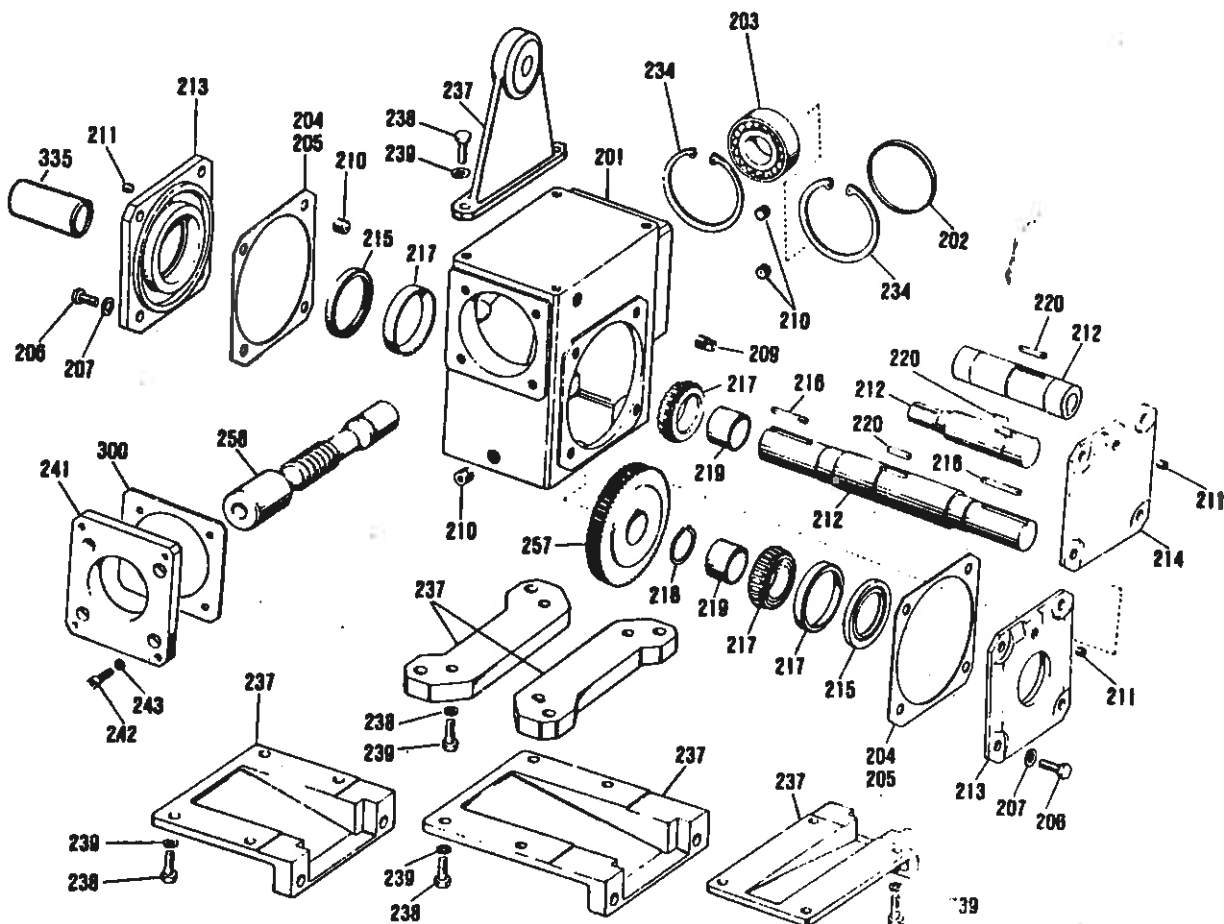

Double Reduction Secondary Unit 262, 325 Series

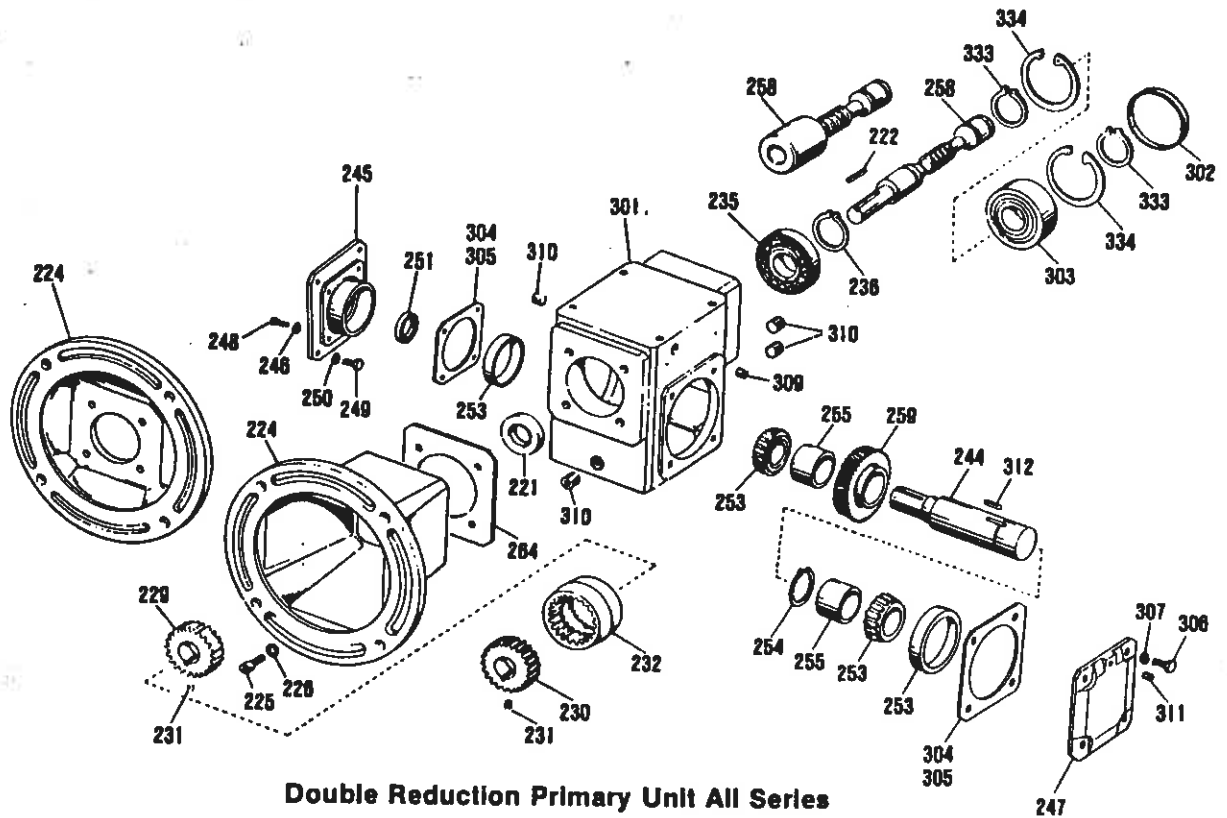

Double Reduction Primary Unit All Series

PARTS LIST
(Applies to all exploded views)

ITEM	DESCRIPTION	ITEM	DESCRIPTION	ITEM	DESCRIPTION
201	Housing	229	Coupling Hub (Unit)	255	Spacer
202	End Cover	230	Coupling Hub (Motor)	256	Worm
203	Bearing	231	Setscrew	257	Gear
204	Shim (.019 Thick)	232	Coupling Sleeve	258	Worm
205	Shim (.007 Thick)	233	Lock Ring	259	Gear
206	Capscrew	234	Lock Ring	260	Thrust Plate
207	Lock Washer	235	Bearing	261	Capscrew
209	Vent Plug	236	Lock Ring	264	Gasket
210	Pipe Plug	237	Base	300	Gasket
211	Pipe Plug	238	Cap screw	301	Housing
212	Output Shaft	239	Lock Washer	302	End Cover
213	Seal Cage	241	Secondary Adaptor	303	Bearing
214	End Cover	242	Capscrew	304	Shim (.019 Thick)
215	Oil Seal	243	Lock Washer	305	Shim (.007 Thick)
216	Key	244	Primary Output Shaft	306	Capscrew
217	Bearing	245	Primary Adaptor	307	Lock Washer
218	Lock Ring	246	Lock Washer	309	Vent Plug
219	Spacer	247	End Cover	310	Pipe Plug
220	Key	248	Capscrew	311	Pipe Plug
221	Oil Seal	249	Capscrew	312	Key
222	Key	250	Lock Washer	333	Lock Ring
224	Motor Flange	251	Oil Seal	334	Lock Ring
225	Capscrew	253	Bearing	335	Shaft Cover
226	Lock Washer	254	Lock Ring		

Note: When ordering replacement parts, specify model number, item number, and part description.



SLC™ 150 Programmable Controller

An Addendum to the SLC 100 User's Manual

How To Use This Publication

This publication is an addendum to the existing SLC 100 User's Manual (Publication 1745-800-800A). The purpose of this publication is to explain programming and operational characteristics that are unique to the SLC 150 Programmable Controller.

Topics discussed in this publication are:

- Processor operating cycle Pg. 2
- SLC 150 processor errors Pg. 3
- I/O addressing Pg. 4
- Programming Pg. 4
- EEPROM auto-load Pg. 5
- TRIAC zero-cross turn on enable Pg. 6
- Fine time base instructions Pg. 7
- Long time base instructions Pg. 7
- ZCL programming Pg. 8
- Break point output instruction Pg. 8
- Auto-baud recognition Pg. 9
- High speed input programming Pg. 9

All other programming and operational characteristics of the SLC 150 are identical to those of the SLC 100. Any information regarding those characteristics can be obtained from the SLC 100 User's Manual (Publication 1745-800-800A) which is provided with the SLC Pocket Programmer (Catalog Number 1745-PT1) or SLC Personal Computer Software (Catalog Number 1745-PCD).

Important Solid State Information

Solid state equipment has operational characteristics differing from those of electromechanical equipment. Because of this, and also because of the wide variety of uses for solid state equipment, all persons responsible for applying this equipment must satisfy themselves that each intended application of this equipment is acceptable.

In no event will Allen-Bradley Company be responsible or liable for indirect or consequential damages resulting from the use or application of this equipment.

The examples and diagrams in this publication are included solely for illustrative purposes. Because of the many variables and requirements associated with any particular installation, Allen-Bradley Company cannot assume responsibility or liability for actual use based on the examples and diagrams.

No patent liability is assumed by Allen-Bradley Company with respect to use of information, circuits, equipment, or software described in this publication.

The contents of this publication are copyrighted. Reproduction of the contents of this manual, in whole or in part, without written permission of the Allen-Bradley Company is prohibited.

© 1986 Allen-Bradley Company

Introduction

The SLC 150 is the newest member of the SLC family of programmable controllers. It uses the same instruction set as the SLC 100 with some added functionality. Major improvements in processing time have also been incorporated to make the SLC 150 one of the fastest and most technically advanced small PC available today.

The SLC 150 Processor Unit features I/O circuitry for 20 inputs and 12 outputs. SLC 150 Expansion Units also have I/O circuitry for 20 inputs and 12 outputs.

A High Speed Input Module can also be connected to the SLC 150 processor unit. The high speed input module allows the SLC 150 processor unit to count high speed input signals (up to 5 KHz). You can connect a maximum of four high speed input modules to the SLC 150 processor unit. Each module can interface to one high speed input device. The high speed input module can only be used with the SLC 150 processor unit.

SLC 100 expansion units can also be used with the SLC 150 processor unit.

Processor Operating Cycle

During each operating cycle, the processor examines the status of input devices, executes the user program, and changes outputs accordingly. This cycle is repeated about 500 times each second for a typical 500 word program.

A single operating cycle or *scan* is illustrated in the figure below. Note that it is divided into two distinct parts – the I/O scan and the program scan. The operating cycle can also contain an interrupt which allows the processor unit to count high speed input signals and immediately set the processor unit outputs associated with a high speed sequencer instruction.

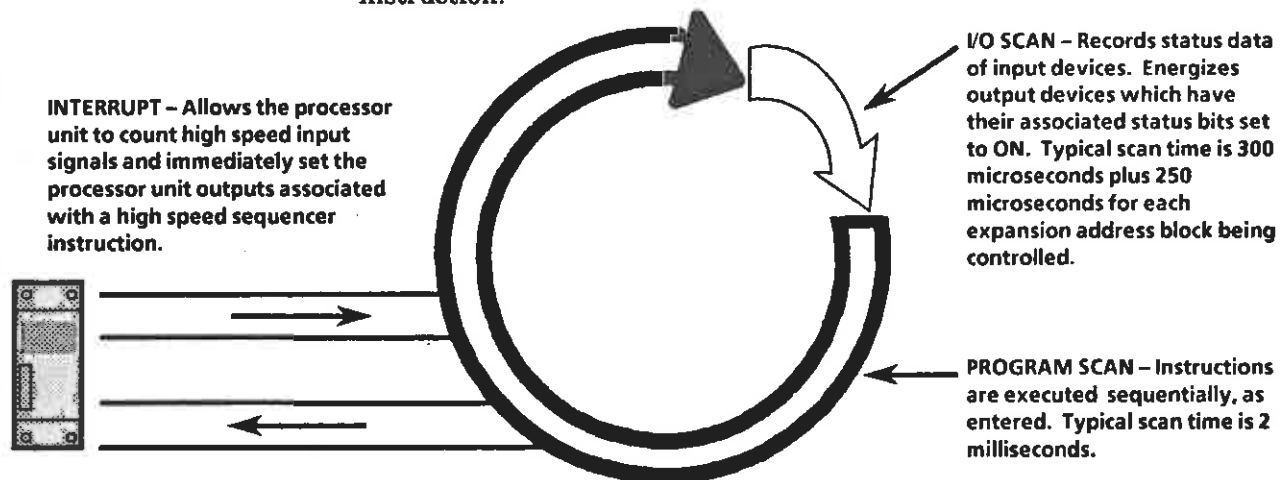

High Speed Input Module.

Operating cycle of the processor. Typical cycle time is 2.5 milliseconds.

Note: Cycle time can vary significantly depending on program content, program length, high speed interrupts, and expansion units connected. Scan times in excess of 100 milliseconds will be detected by the processor and cause system shutdown. Consult the SLC 100 User's manual for ladder programs describing scan time measurement techniques.

SLC 150 Characteristics and Programming Basics

I/O Scan During this part of the cycle, data associated with external outputs is transferred from the data table to the corresponding output terminals. (This data was updated during the preceding program scan.) In addition, input terminals are examined, and the associated status bits are changed accordingly.

Program Scan The updated status of the input devices are applied to the user program during this part of the cycle. The processor executes the entire list of instructions in the same order they were entered. Status bits are updated according to logical continuity rules as the program scan moves from instruction to instruction thru successive ladder rungs.

The I/O scan and program scan are separate, independent functions. Thus, any status changes occurring in external input devices during the program scan are not accounted for until the next I/O scan. Similarly, data changes associated with external outputs are not transferred to the outputs until the next I/O scan. Exceptions to this rule are High Speed Input module applications which allow the processor unit to count high speed input signals and immediately set processor unit outputs associated with a high speed sequencer instruction.

SLC 150 Processor Errors

Three additional error conditions can be detected by an SLC 150 processor unit. When any of these conditions occur, the CPU fault indicator will illuminate and outputs will be disabled. The pocket programmer can be connected to display error codes. The pocket programmer will display error code 27 for all of the errors listed below. Pressing the CANCEL CMD key on the programmer will display a second number in the error code that will identify the error as one of the three listed in the table below.

ERROR CODE	DESCRIPTION	REMEDY
27-1	High Speed Input Module Problem	<ul style="list-style-type: none"> • Check high speed input module connection • Check for insufficient number of high speed input modules to support your program • Check user program for two high speed sequencer instructions at the same address
27-2	Zero-Cross Turn On Failure	<ul style="list-style-type: none"> • Check to make sure AC powered unit is used when using address 866 • Hardware failure. Contact your local A-B representative for repair or replacement.
27-5	ZCL Programming Error	<ul style="list-style-type: none"> • Check your program for nested ZCLs in excess of 8. • Check your program to make sure there is a ZCL end rung for every ZCL start rung.

SLC 150 Characteristics and Programming Basics

I/O Addressing

The SLC 150's I/O image table consists of 112 I/O, divided into 7 address blocks (10 input addresses and 6 output addresses per block) as shown in the table below. The processor unit uses the first 2 address blocks. Each SLC 150 expansion unit also uses 2 address blocks. SLC 100 expansion units can also be connected to an SLC 150 processor unit. Most of these units use only 1 address block. Refer to Publication 1745-2.2 for more information on SLC 100 expansion unit address blocks. The processor unit automatically assigns expansion unit addresses based on their location in the series chain. For your convenience, write-on areas are provided to help identify the addresses associated with each expansion unit.

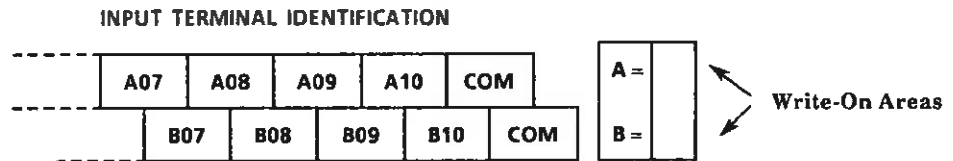

If an SLC 150 expansion unit is connected to an SLC 150 processor unit, address numbers 201 thru 210 and 301 thru 310 would be assigned to the inputs of the expansion unit. A above would equal 2. B would equal 3.

SLC 150 EXPANSION UNIT ADDRESSING			
Assigned to	Address Block Number	Input Addresses	Output Addresses
Processor Unit	1	1-10	11-16
	2	101-110	111-116
1st Expansion Unit	3	201-210	211-216
	4	301-310	311-316
2nd Expansion Unit	5	401-410	411-416
	6	501-510	511-516
3rd Expansion Unit*	7	601-610	611-616

* Only 16 addresses are available for the last SLC 150 Expansion Unit. However, an SLC 100 Expansion Unit (16 I/O) could be used here so that I/O circuitry is not wasted.

Programming

The SLC 150 can be programmed with the same pocket programmer (Cat. No. 1745-PT1) used to program the SLC 100. Personal Computer Software for programming the SLC 150 is also available. Programs developed for use with the SLC 100 are compatible with the SLC 150, however programs developed for use with the SLC 150 are not completely compatible with the SLC 100 because of the unique functionality of certain address bits in the SLC 150 (see Page 5).

Caution: Programs developed for use in the SLC 100 may contain addresses that have special functionality unique to the SLC 150 (see Page 5). If you are using a program developed for use in an SLC 100 with an SLC 150 processor unit, be aware of these addresses as they may cause improper operation and damage to your equipment.

SLC 150 Characteristics and Programming Basics

EEPROM Auto Load (continued)

With SLC 100 and SLC 150 Processor Units:

If an access code is stored in the EEPROM and it does not match an access code stored in the processor unit NVRAM memory, the auto load will not occur and the pocket programmer must be used.

Address 864

With the SLC 150, the EEPROM auto-load procedure can be used for clearing processor faults caused by memory checksum errors (Error codes 5 and 8, see processor fault detection, SLC 100 User's Manual, Page 21-5). Memory checksum errors will be detected by the processor unit if memory data is altered or lost due to capacitor back-up drain, battery back-up drain or processor malfunction.

This feature is user programmable. In order for memory checksum errors to be cleared, the first rung in your user program must contain the unconditional rung shown below.

```

rung 1                                     864
-----] \ (-----) -----

```

This rung is necessary to initiate the auto load process when there is a memory checksum error detected. When an EEPROM is installed in the processor unit, the EEPROM program will be loaded into the NVRAM memory when power is applied to the processor unit and a memory checksum error is detected. Loading the EEPROM program to NVRAM will clear the checksum error. The auto load procedure only occurs in the Run mode. If an access code is stored in the EEPROM, that code will be loaded with the program.

IMPORTANT: I/O table data is cleared when the EEPROM auto-load procedure is used for clearing memory checksum errors. This means that all retentive instructions (latches, timers, counters, sequencers) will be reset to their initial states.

Battery Status (Address 865)

A status bit at address 865 can be examined for battery status. The status bit is ON when the battery is O.K. and is set OFF when the battery voltage falls below a certain threshold. When the status bit is set OFF, the battery will only have sufficient voltage to support memory for approximately 2 weeks. The output instruction in the rung below can be used to energize an external battery low light. Assign an address to the output instruction that corresponds to an available output circuit.

Battery low status is only indicated when power is being provided to the processor unit.

```

      865                                     XXX
-----] \ (-----) -----

```

Note: Battery back-up in the SLC 150 is optional. If the battery is not used, status bit 865 will always remain ON.

Triac Zero-Cross Turn On Enable (Address 866)

Triac outputs can be synchronized with the AC line to accomplish zero-cross turn on. This can help minimize noise generated when switching loads. Note that a common power source must be used for the processor unit power supply and output circuits to achieve zero-cross turn on.

SLC 150 Characteristics and Programming Basics

**Triac Zero-Cross
Turn On Enable
(Address 866)
(continued)**

To enable triac zero-cross turn on, status bit address 866 must be set ON in your user program. A conditional rung can be programmed as shown below and located anywhere in your program. An unconditional rung could be used in place of the conditional rung.



NOTE: Since this feature synchronizes your program scan with the AC line zero-cross, program scan time will be equal to 8.3 msec (or some multiple of) at 60 Hz and equal to 10 msec (or some multiple of) at 50 Hz.

**Fine Time Base
Instructions**

The following adjustments have been made to SLC 150 fine time base instructions in order to facilitate integral time bases.

INTERNAL ADDRESS	TIME INCREMENT IN MILLISECONDS	
	SLC 100	SLC 150
869	Scan Rate	Scan Rate
870	10	10
871	20	20
872	40	50
873	80	100

ACCEPTABLE ADDRESSES FOR YOUR MEASURED SCAN TIME WITH THE SLC 150	
Your Measured Scan Time in Milliseconds	Acceptable Internal Addresses
less than 5.0	870, 871, 872, 873
5.0 to 9.9	871, 872, 873
10.0 to 29.9	872, 873
30.0 to 49.9	873
Any value less than 100	869

**Long Time Base
Instructions**

As with SLC 100, the SLC 150 provides long time bases to facilitate long time delays. With the SLC 150 processor unit, the 1.0 second time increment is synchronized with the AC line when using AC powered processor units (1745-LP151, 1745-LP152). This synchronization allows this time increment to be used for creating "real time" clock applications. AC line synchronization is not provided on Catalog Number 1745-LP153 or 1745-LP154 processor units.

INTERNAL ADDRESS	TIME INCREMENT IN MILLISECONDS
874	500 (0.5 sec) based on microprocessor clock
875	1000 (1.0 sec) based on microprocessor clock (Cat. No. 1745-LP153, -LP154)
875	1000 (1.0 sec) based on AC line frequency (Cat. No. 1745-LP151, -LP152)

ZCL Programming

With the SLC 150, it is possible to nest ZCL zones. This is not possible with the SLC 100. This means that one zone can be surrounded (and controlled) by another zone. Up to 8 zones can be nested together. All zones must contain a start rung and an end rung. If ZCL zones are nested deeper than 8 zones or if each start rung is not accompanied by an end rung, a processor fault will occur. Error code 27-5 will be displayed by the pocket programmer (see processor error codes on Page 3).

ZCL operation is similar with nested zones. When the start rung of an outer zone is TRUE, all internal zones will operate normally. When the start rung of an outer zone is FALSE, all outputs within internal zones will be held in their last state* regardless of the rung conditions of the internal zones.

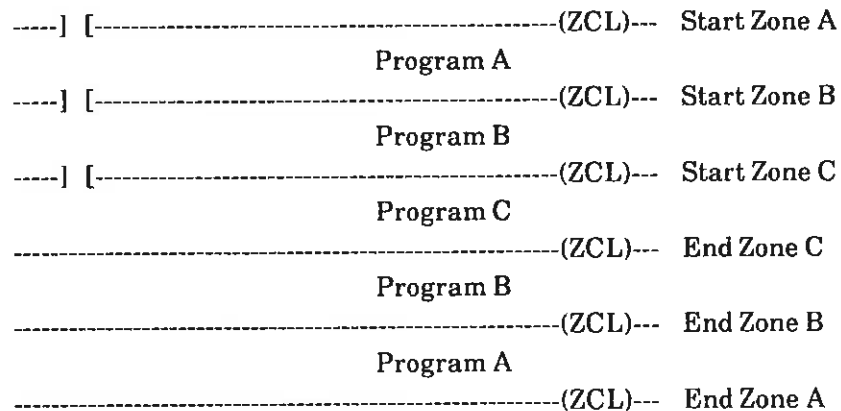

In the figure above, ZCL zone A controls the outputs in programs A,B, and C. ZCL zone B controls outputs in programs B and C. ZCL zone C controls outputs in program C. An outer zone must be TRUE in order for internal zones to control their outputs. If an outer zone is FALSE, all outputs within internal zones are held in their last state* regardless of the rung conditions of the internal zones.

*Note: Outputs in FALSE ZCL zones that are held in their last state can be controlled by rung conditions that are external to ZCL zone control.

Break Point Output Instruction

A Break Point output instruction can be programmed in your SLC 150 ladder program by programming an output instruction at address 100. When the rung containing this output instruction is TRUE, the SLC 150 processor unit will halt its scan, automatically switch from the Run mode to the Test-Single Scan Mode, and turn all outputs OFF. The processor unit will stop its program scan at the point in your ladder diagram where the TRUE break point output instruction is located.

When these conditions occur, the pocket programmer can be connected and it will display the TRUE break point output instruction (brP) and its rung number. SLC Personal Computer Software will also provide a message telling you that a break point -(BPT)- has occurred at a specific rung number. A break point output rung can be programmed as many times as you need it in your program.

```

      XXX   YYY
-----] \ [-----] [------( BPT )-----
  
```

Break Point Output Instruction
(continued)

The break point output instruction can be used for debugging new programs and troubleshooting applications by pin pointing ladder diagram logic problem areas. This same break point output instruction is also available in SLC 100 processor units however it is not discussed in the SLC 100 User's Manual.

Insert the break point output rung after the portion of your ladder program that you suspect is not operating correctly. The conditions that make the break point output instruction TRUE should be the conditions that you suspect would cause your program to malfunction. Place the processor in the Run mode and test your program. If the processor unit halts and outputs are disabled, the break point output instruction has been made TRUE. Connect the pocket programmer and it will automatically identify the rung number and conditions causing the break point.

Important: Do not use the break point output instruction for emergency stop situations. We strongly recommend that you use a hard-wired master control relay to provide emergency I/O power shutdown.

Auto-Baud Recognition

The SLC 150 processor unit will automatically adjust its communication baud rate in any mode but the Run mode to allow communication with external devices such as computers and modems. Acceptable communication baud rates are 300, 1200, 2400, 9600 and 19,200. If the SLC 150 is in the Run mode and you want to communicate at a different baud rate, you must remove power to the Processor unit or switch the processor unit from the Run mode to any other operating mode. Then connect the external device you want to communicate with.

If you remove power to the Processor unit in the Run mode, the AUTO-MAN switch must be set to the MAN position in order for the baud rate to be adjusted on power-up. Once power is applied, you can return the switch to the AUTO position.

HSI Module Mounting, Wiring, and DIP Switch Settings

Refer to Publication 1745-2.7 (provided with the High Speed Input Module) for information on mounting, wiring, and DIP switch settings.

High Speed Input (HSI) Module Programming

The SLC 150 can count high speed pulses from up to four input devices each connected to a high speed input module. In order to count these high speed pulses, an event driven output sequencer -(SQO)- must be used in the SLC 150 ladder program. Acceptable addresses are shown below. You should be familiar with sequencer programming before you attempt to program a high speed counting application. Refer to Chapter 11 of the SLC 100 User's Manual.

ACCEPTABLE ADDRESSES FOR THE HSI SEQUENCER INSTRUCTION	
HSI Sequencer (SQO) (Event) Address	Will count pulses fed into
901	1st High Speed Input Module
902	2nd High Speed Input Module
903	3rd High Speed Input Module
904	4th High Speed Input Module
<p>Note: The contiguous addresses shown above must coincide with the physical location of high speed input modules when they are connected in series. Unused addresses may be used for standard timer, counter, and sequencer programming.</p>	

SLC 150 Characteristics and Programming Basics

High Speed Input (HSI) Module Programming (continued)

In order to designate an -(SQO)- as a high speed input counter, it must be immediately preceded by an Examine OFF instruction with the same address as the -(SQO)- as shown in the ladder diagram on the next page. Additional examine instructions can be used to enable/disable the counting process. When rung conditions are TRUE, the HSI sequencer counter is enabled and it will begin to accumulate pulses fed into its corresponding HSI module. When the accumulated count is equal to or greater than a user programmed preset, the HSI sequencer will advance to its next step and set outputs corresponding to the new step. Output addresses on the processor unit (Grp 0 and 1 – addresses 11-18 and 111 - 118) are updated immediately when controlled by an HSI sequencer. Output addresses on expansion units (groups 2-69) are updated at the end of the program scan.

Up to 100 steps, each with its own preset can be programmed with an HSI sequencer. HSI sequencer instructions may not be cascaded to control more than 8 output addresses.

The HSI sequencer can be reset with two different types of -(RST)- instructions; a normal -(RST)- instruction and a single shot -(RST)- instruction. See example next page.

When the normal -(RST)- instruction is TRUE, it immediately disables high speed counting, resets the HSI sequencer to the programmed reset step, and holds the sequencer at that step number until -(RST)- rung conditions go FALSE.

The single shot -(RST)- instruction can be used in conjunction with a single shot program in order to reset an HSI sequencer to a specific step without losing any high speed input counts. The single shot -(RST)- instruction resets the HSI sequencer only for the period of time that it takes to execute the reset function. After the reset function is complete, the HSI sequencer will resume operation from the programmed reset step number. Any high speed pulses occurring during the reset function will be applied to the accumulator at the step number that the sequencer is being reset to.

The single shot -(RST)- instruction is designated by using a 4 digit reset value. The first two digits must be 99 and the second two digits are the step number you wish to reset to.

Status bit addresses and maximum pulse rates associated with the HSI sequencer are listed in the tables below.

MAXIMUM PULSE RATE		
HSI Modules Connected	Highest Single Frequency (Hz)	Highest Total Frequency (Hz)
1	5	5
2	4	5
3	3	5
4	2	5

Note: If maximum or total frequencies are exceeded, status bit 901-904 will be set ON.

ADDRESS	FUNCTION
901-904	<ul style="list-style-type: none"> Acceptable addresses for HSI sequencer instruction. An \bar{I} instruction at this address preceding the -(SQO)- designates it as an HSI. Set ON when over speed detected and disables the -(SQO)- and counting process (See chart at left). When this happens, the -(SQO)- is held in its last state with respective outputs applied. The over speed conditions must be corrected and the -(RST)- must be set TRUE in order to reset the over speed status bit to OFF.
951-954	<ul style="list-style-type: none"> Set ON for one program scan when sequencer cycle (last step) is completed.

High Speed Input (HSI) Module Programming Example

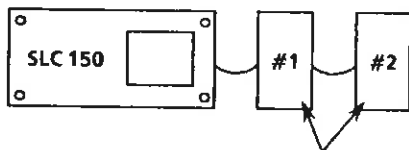

High Speed Input Modules

You can program any rung conditions. TRUE rung conditions enable the -(SQO)- counter.

This instruction must immediately precede -(SQO)- in order to designate it as a high speed counter. It is set FALSE and disables the -(SQO)- if the maximum pulse rate is exceeded.

This instruction (address 901 + 50) will be set TRUE for one program scan when -(SQO)- at address 901 completes its last step.

When -] [- at address 2 is TRUE, -(RST)- 901 will immediately disable high speed counting. It will reset HSI/-(SQO)- 901 to step 0, and apply the outputs for that step. The sequencer will be held on that step until the rung is FALSE.

When -] [- at address 4 is TRUE, the sequencer step completion instruction -] [- 910 is set TRUE for one program scan which makes -(RST)- 902 TRUE. -(RST)- 902 momentarily resets HSI/-(SQO)- 902 to step 0 without losing any high speed counts.

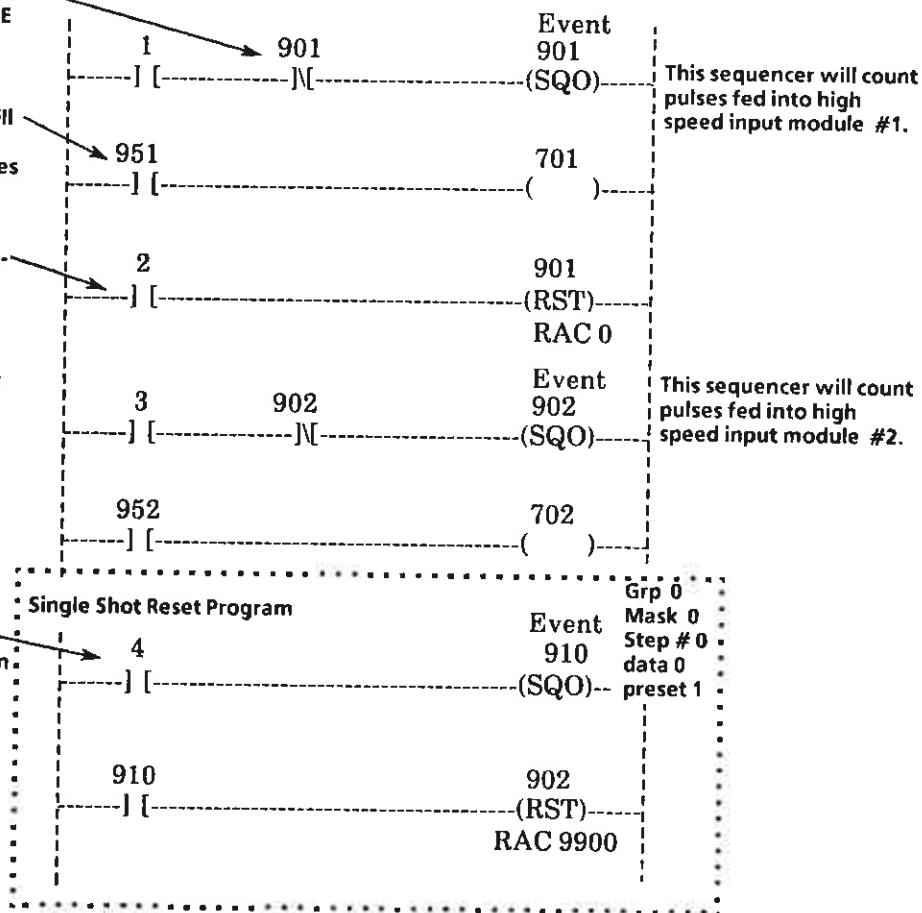

SLC 150 Characteristics and Programming Basics

Application Example 1 Two Step Cut-Off Operation

A high speed cut-off operation measures metal strips by counting pre-formed bumps as the metal strip is fed into the cut-off area. The bumps pass a solid state sensor at the rate of 1000 bumps per second. Every 2000 bumps, the strip is cut. The counting process then resumes.

In the program below, a 2 step sequencer is used to perform the counting and cut-off operation. Outputs controlled by -(SQU)- at address 901 include the feed motor and the cut-off saw motor. -(SQU)- is enabled only when the cut-off saw is in the home position.

In step 0, the feed motor is energized which feeds the metal strip. As the strip is fed, the bumps are counted by the -(SQU)- counter. When 2000 counts are reached, the -(SQU)- instruction advances to step 1. This lowers the cut-off saw which cuts the strip and returns to the home position.

When the cut-off saw returns to its home position a limit switch -] [- at address 1 is closed initiating a single shot reset that resets the process back to step 0. This single shot reset allows the feeding process to resume and high speed input signals to be counted immediately. The preset of 9999 for step 1 has been arbitrarily chosen and allows for over feeding of the metal strip. The preset for step 1 could be set to any four digit number except zero since the process is reset when the saw returns home.

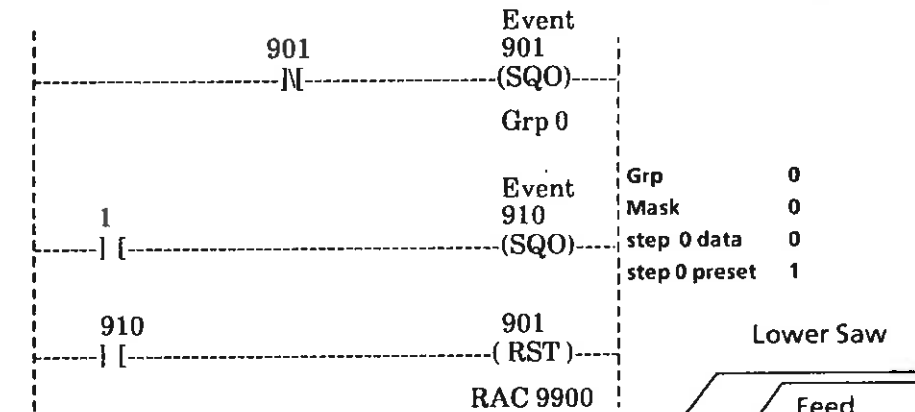

rung 1 SQU data

	18	17	16	15	14	13	12	11	
MASK	03	0	0	0	0	0	1	1	
STEP	00	0	0	0	0	0	0	1	Preset 2000
	01	0	0	0	0	0	1	0	Preset 9999

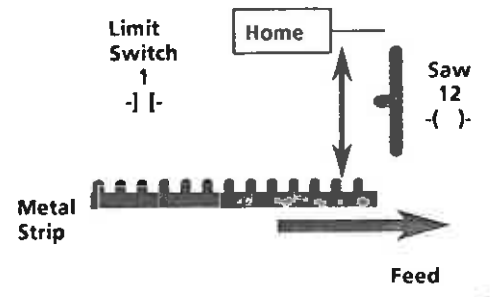

Application Example 2
Multiple Step Position
Control

Drill position and hole depth are controlled by counting high speed input pulses from an encoder mounted on a feed motor. The feed motor turns a lead screw which moves the drill forward and backward. As the feed motor turns, encoder pulses are fed into the SLC 150 High Speed Input Module at a rate of 5000 pulses per second.

Step 0 of the process is the home position with all outputs OFF. The preset of 9999 for step 0 has been arbitrarily chosen and allows for encoder movement without advancing the sequencer step number. A push button at address 001 initiates the process by performing a single shot reset which moves the process to step 1 where the feed motor is energized. Encoder pulses are then counted by the HSI/-(SQO)- at address 901. After 9000 counts, the drill motor is turned ON (step 1) in preparation for drilling the part.

After another 2000 pulses, the drill bit has reached its proper depth in the part and the sequencer advances to step 3. Step 3 reverses the feed motor and retracts the drill. After 2000 pulses the drill motor is turned OFF and the drill continues to retract until its original position is reached.

When the operation cycle is complete, the process returns to step 0 which is the home position with all outputs OFF.

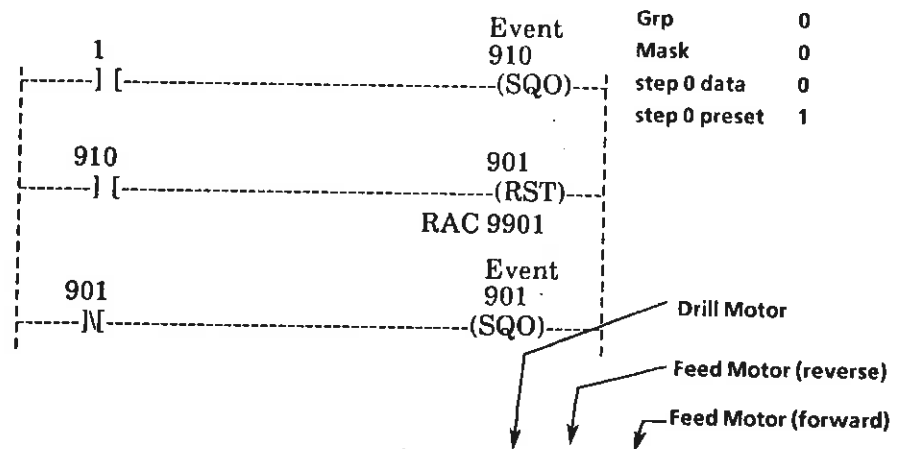
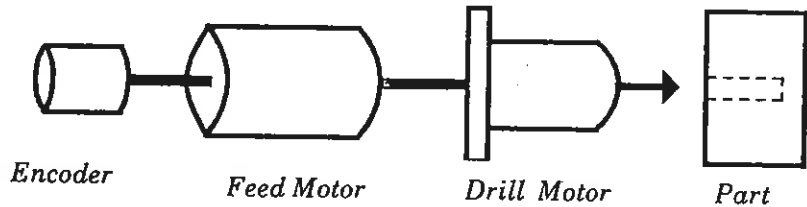

	18	17	16	15	14	13	12	11	
MASK 07	0	0	0	0	0	1	1	1	preset
STEP 00	0	0	0	0	0	0	0	0	9999
01	0	0	0	0	0	0	0	1	9000
02	0	0	0	0	0	1	0	1	2000
03	0	0	0	0	0	1	1	0	2000
04	0	0	0	0	0	0	1	0	9000

Special HSI Considerations

1. As the frequency of your HSI sequencer counts increase, your scan time will also increase. Using HSI sequencer step presets of one will further increase your scan time. A scan time in excess of 100 milliseconds will be detected by the processor unit and cause system shutdown. You should verify your scan time at the maximum HSI input rate to assure proper operation of your system. Refer to the SLC 100 User's Manual Page 9-2 for instructions on measuring your scan time.
2. When the SLC 150 processor unit is placed in the Test-Single Scan mode and the HSI sequencer start rung is TRUE, the HSI will count in real time and the accumulator will increment as it would in the Run mode.
3. The HSI module should not be connected or disconnected when power is applied to the SLC 150 processor unit.

WARNING: Improper operation and damage to equipment or personnel could occur if the HSI is connected or disconnected when power is applied to the SLC 150 processor unit.

4. The HSI module is shipped with an end plug inserted in the expansion socket. If the HSI module is the last module connected in your system, the end plug must remain inserted. Removing the end plug from the HSI module (if it is the last module connected in your system), will cause a CPU fault and your system will shut down in the Run mode.

If an I/O expansion unit is connected to the HSI module, the end plug must be removed.

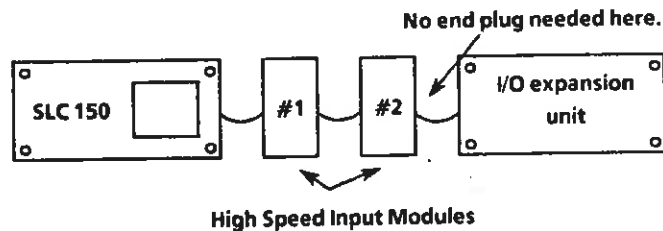
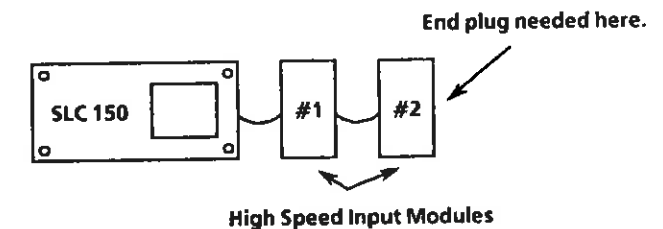

High Speed Input Module End Plug Placement Requirements.



SLC™ 150 Programmable Controllers

Important Clarification To

SLC 150 Processor Unit Product Data Publication 1745-2.5, Page 9
 SLC 150 Expansion Unit Product Data Publication 1745-2.6, Page 10

Refer to the diagrams below when connecting line power wires to your SLC 150 processor unit or expansion unit.

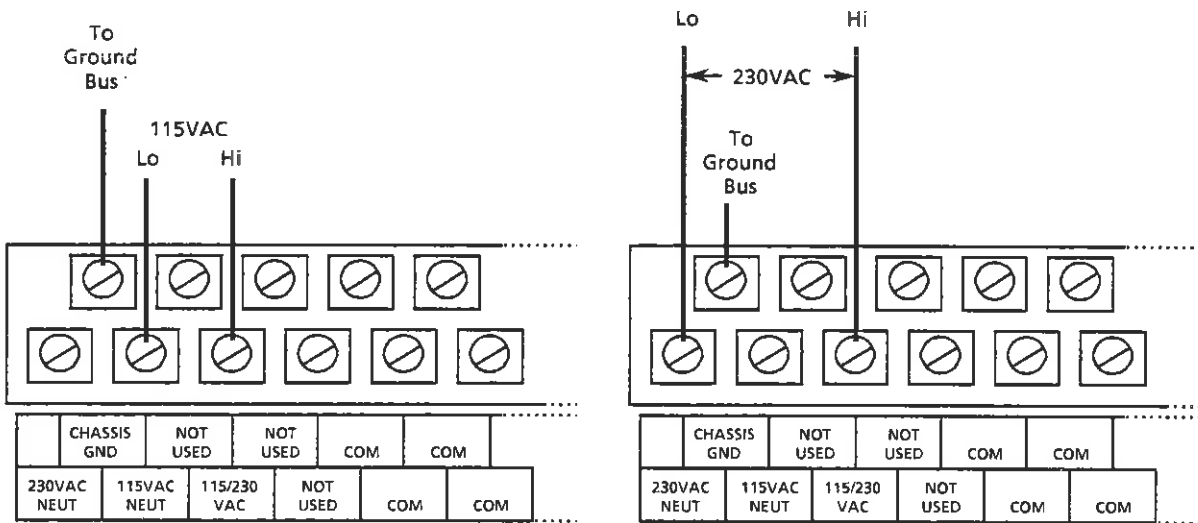

Catalog Nos. 1745-LP151, -LP152, -LP153, -E151, -E152, -E153

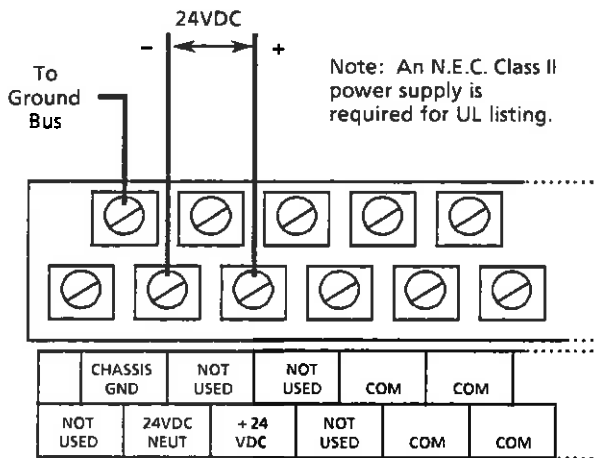

Catalog Nos. 1745-LP154, -E154

CAUTION: Incorrect wire connections can cause damage to the SLC 150 processor unit or expansion unit power supply. **Do not** jumper 115VAC NEUT and 230VAC NEUT together. **Do not** jumper unused 115VAC NEUT or unused 230VAC NEUT to the CHASSIS GND terminal.

SLC™ 150 Programmable Controllers

Important Clarification To

SLC 150 Processor Unit Product Data Publication 1745-2.5, Page 9
 SLC 150 Expansion Unit Product Data Publication 1745-2.6, Page 10

Refer to the diagrams below when connecting line power wires to your SLC 150 processor unit or expansion unit.

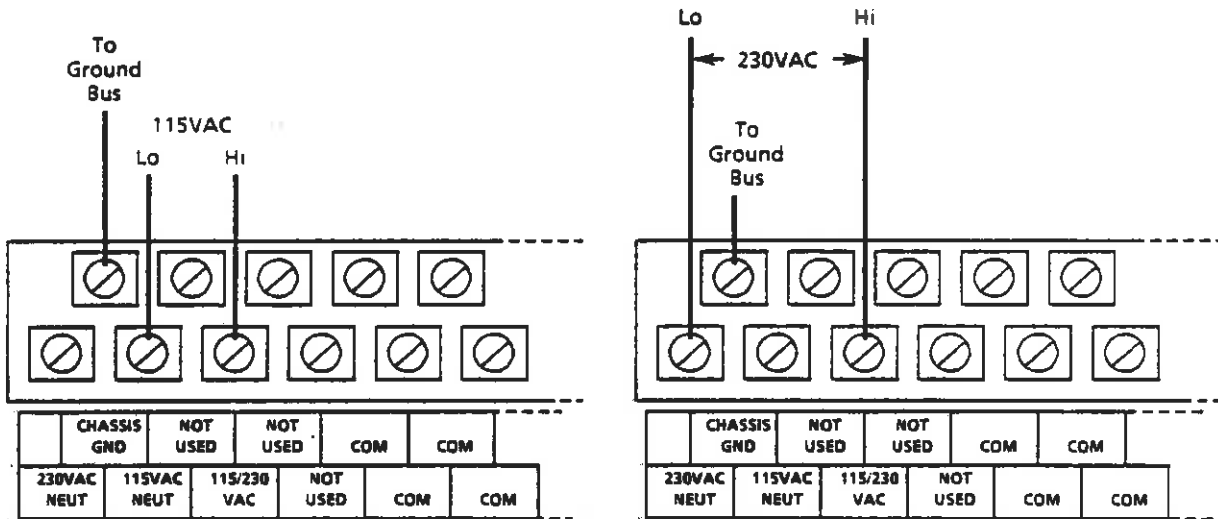

Catalog Nos. 1745-LP151, -LP152, -LP153, -E151, -E152, -E153

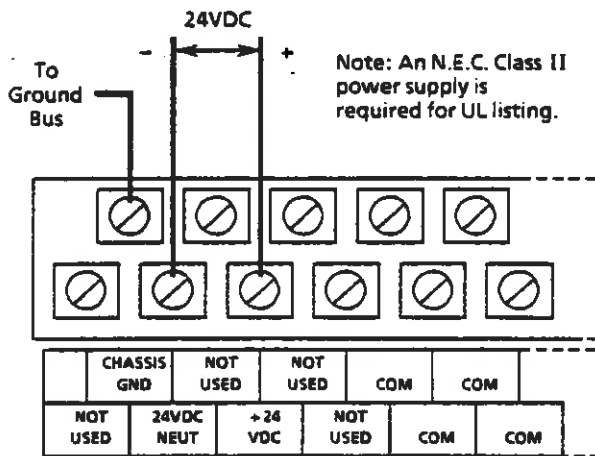

Catalog Nos. 1745-LP154, -E154

CAUTION: Incorrect wire connections can cause damage to the SLC 150 processor unit or expansion unit power supply. **Do not** jumper 115VAC NEUT and 230VAC NEUT together. **Do not** jumper unused 115VAC NEUT or unused 230VAC NEUT to the CHASSIS GND terminal.





SLC™ 150 Programmable Controller

Processor Unit – Catalog Nos. 1745-LP151, -LP152, -LP153, -LP154

The SLC 150 Programmable Controller

The SLC 150 Programmable Controller features high-speed operation and I/O versatility. It can be used in a wide variety of applications, including:

- Machine tools
- Material handling
- Assembly machines
- Molding and casting machines
- Robotics
- Energy management

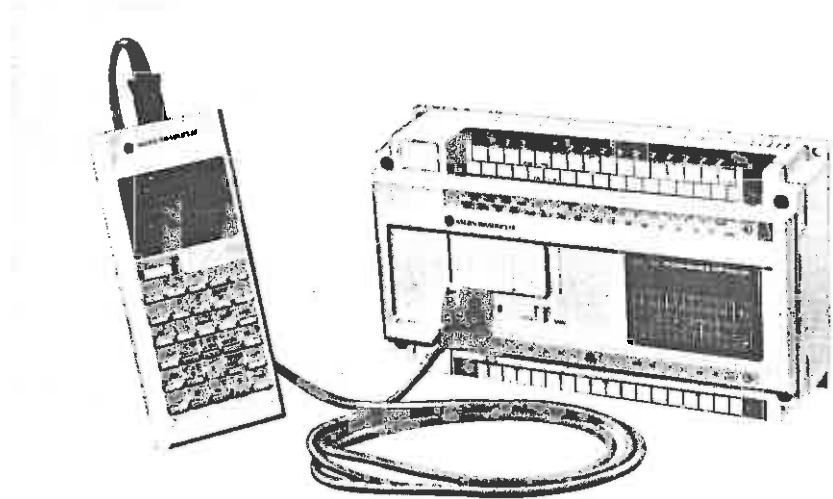

SLC 150 Programmable Controller with Pocket Programmer connected.

The Processor Unit

The heart of the SLC 150 is the processor unit, which integrates processor, CMOS RAM memory, and I/O circuitry for 20 inputs and 12-outputs. I/O capability includes AC and DC inputs and triac, transistor and hard contact outputs.

SLC 150 expansion units also provide 32 I/O and can be connected to the processor unit to increase the I/O capacity to a maximum of 112. SLC 100 expansion units (16 I/O) can also be connected to the processor for added flexibility. Expansion units are available with AC, DC, high speed, and analog inputs along with triac, transistor, and hard contact outputs. Further information on expansion units can be found in the SLC 100 User's Manual and Publications 1745-2.2, 1745-2.6, and 1745-810.

The pocket programmer, supplied with a 6-ft interconnect cable, is used to program the controller. SLC Personal Computer Software (IBM compatible) can also be used for programming. The illustration above shows the pocket programmer plugged into the processor unit. The ladder diagram programming format is used.

Processor Unit – SLC 150

The Processor Unit (continued)

The SLC 150 is also compatible with the following SLC family peripherals:

- EEPROM module (Series B, or Series A 28 pin chip only)
 - Timer Counter Access Terminal (TCAT)
 - Personal Computer Interface Converter and software
-

Processor Operating Modes

Nine processor operating modes can be selected. These are:

- | | |
|-------------------------------------|---|
| Mode 1: Clear Memory | Mode 6: Store Program in EEPROM |
| Mode 2: Program | Mode 7: Load Program from EEPROM |
| Mode 3: Run | Mode 8: Enter/Change Access Code |
| Mode 4: Test–Single Scan | Mode 9: Diagnostic Test–Programmer |
| Mode 5: Test–Continuous Scan | |
-

Processor Features

The following features are pointed out in the illustration on Page 3.

1. Incoming line wiring terminals including removable terminal block for easy processor replacement. Self-lifting pressure plates allow for easy wire insertion and secure connections. Terminals accept two #14 AWG wires. A hinged cover is provided.

2. Wiring terminals for 20 inputs including removable terminal block. Same construction as line terminals. The hinged cover has write-on areas for identification of external circuits.

The processor unit has a color coded patch to identify the catalog version. The color code is discussed on Page 15.

3. Wiring terminals for 12 outputs including removable terminal block. Same construction as line terminals. Hinged cover has write-on areas to identify external circuits.

4. 5 red LED diagnostic indicators:

DC POWER – Indicates that the processor unit is energized and DC power is being supplied.

PC RUN – Indicates the processor unit is in the Run mode.

CPU FAULT – Indicates the processor has detected an error in either the CPU or memory. Operation is automatically stopped.

BATTERY LOW – An optional battery provides back-up power for the CMOS RAM memory. This LED alerts you when the battery voltage level has fallen below a threshold level.

FORCED I/O – Indicates that one or more input or output addresses have been forced to an ON or OFF state.

5. Input power fuse compartment. If line terminal voltage is present but the DC POWER LED is not lit, the fuse may be blown. Refer to page 9 for fuse replacement procedure.

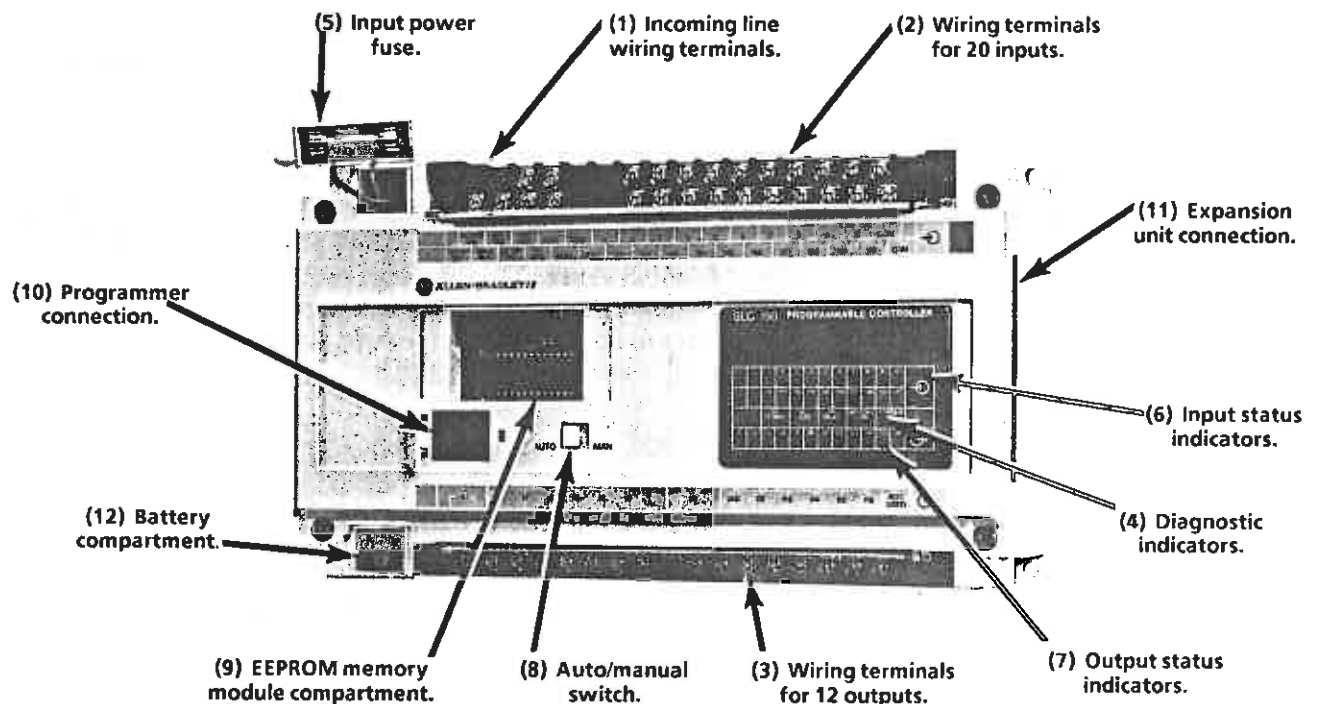

Processor Features (continued)

6. Input status indicators. Twenty red LEDs, identified with address numbers 1 thru 10, 101 thru 110 corresponding to numbers on the input device wiring terminals. When an input circuit is energized, the corresponding status indicator will be lit.
7. Output status indicators. Twelve red LEDs, identified with address numbers 11 thru 16, 111 thru 116, corresponding to numbers on the output contact wiring terminals. When a programmed output instruction is TRUE, the corresponding output status indicator will be lit, and the corresponding output circuit will be energized.
8. Auto/Manual switch. This switch controls restarting of the processor unit after a power loss or brown-out.

Auto – On power-up, the processor runs thru its normal diagnostic tests and then automatically enters the Run mode (if it was in the Run mode at the last power-down).

Manual – On power-up, the processor runs thru its diagnostic tests but will not enter the Run mode. To enter the Run mode, you must move the switch to the auto position or use the pocket programmer.
9. EEPROM memory module compartment. The optional memory module can be plugged into the processor. Mode 6 allows you to store your program (RAM to EEPROM). Mode 7 allows you to load a program in the processor unit (EEPROM to RAM).

Processor Unit – SLC 150

Processor Features (continued)

10. Programmer connection. Plug the pocket programmer cable into the processor unit when you want to program, edit, or monitor controller operation. The cable is provided with the programmer.
11. Expansion unit connection. Expansion units are connected via ribbon cable to this socket. A 20 pin to 10 pin cable is provided with the processor unit for connecting expansion units. Refer to Pages 7 and 8 for details.
12. Battery compartment. Back-up power for the CMOS RAM can be provided by a replaceable battery assembly, accessible from the front of the processor unit. The lithium battery provides back-up power for a typical life of 2-3 years. This battery is optional. Standard back-up power during power loss is provided by a capacitor providing 1-2 week back-up. Refer to Page 14 for battery installation procedures.

Important Installation Considerations

Refer to the SLC 100 User's Manual for details on the following important installation considerations:

- The enclosure should be adequate (NEMA approved) for the environmental conditions of the particular application.
- The processor unit, expansion units, and input/output device circuits should have the same power source. The processor and expansion units should be properly grounded.
- Include an electrical disconnect in the enclosure. An isolation transformer may also be required.
- A master control relay circuit should be included to permit disabling of the I/O devices independent of the processor and expansion unit power supply circuit. One or more emergency-stop switches should also be included.
- Follow recommendations for component spacing within the enclosure, to help keep the controller temperature within the specified limits.
- Wiring should be routed to minimize the effects of electrical noise. Surge suppressors should be used for inductive loads in series with hard contacts and for other noise-generating equipment.
- Fusing should be provided to protect loads and wiring from short circuits or overloading.

System Layout and Recommended Spacing

The figure below shows acceptable layouts. Follow the recommended minimum spacing to allow for convection cooling within the enclosure. Cooling air in the enclosure must be kept within a range of 0° to 60°C.

Note that SLC 150 and SLC 100 expansion units can be interconnected with either an SLC 150 or an SLC 100 processor unit. High speed input modules can be used with the SLC 150 processor unit only.

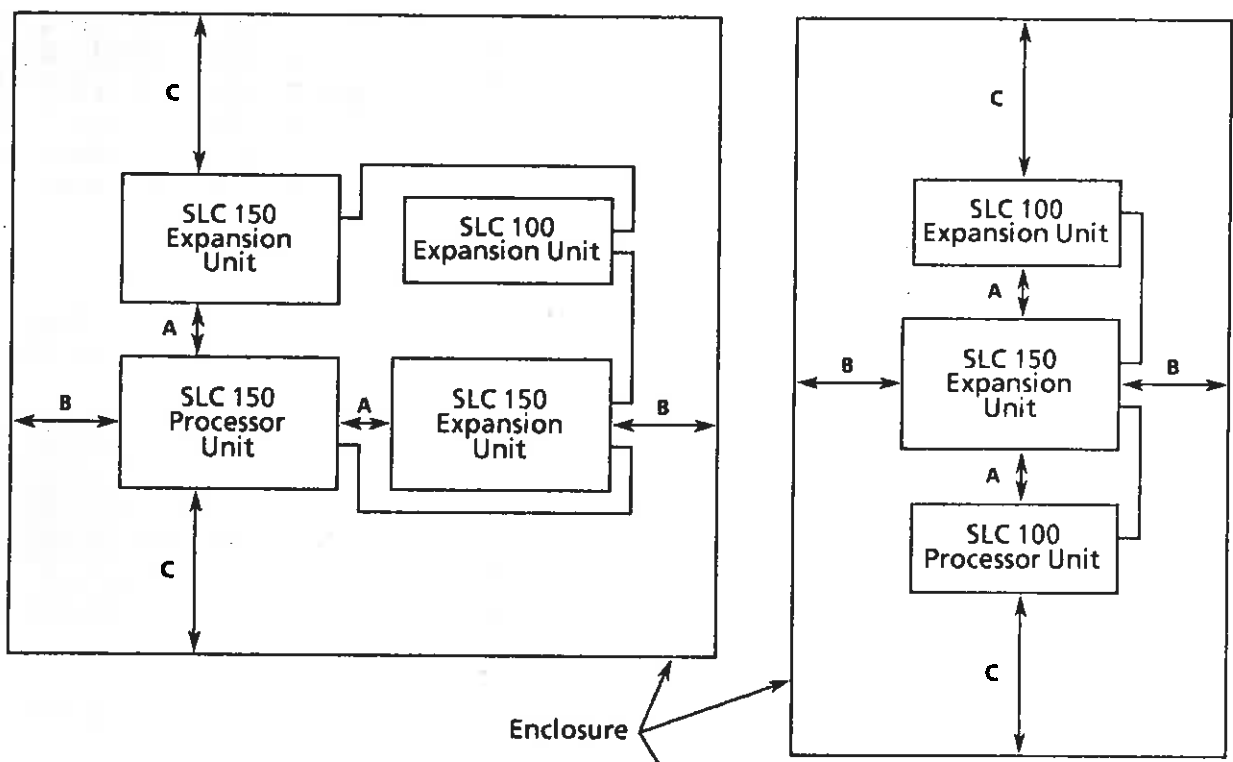

Enclosure

Recommended Minimum Spacing

- A: 2" (51mm)
- B: 4" (102mm)
- C: 6" (152mm)

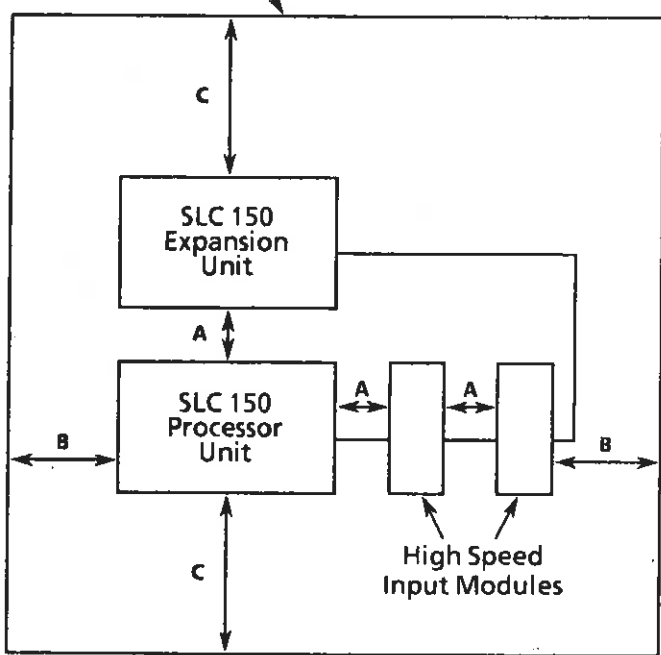

Mounting

The processor unit should be mounted directly to the back panel of your enclosure using four #10 screws. Hole locations are shown in the dimension drawing below.

IMPORTANT: Mount the unit on a smooth metal back panel to provide good thermal conductivity. Back panel temperature specification: 60°C maximum.

SLC 150 processor and expansion units utilize the mounting back panel as a heat sink for dissipating excess heat generated during operation. In high ambient temperature applications (60°C), sub panels not exposed to air outside the enclosure could heat up beyond 60°C. In these situations, the sub panel temperature can be reduced by removing other heat generating equipment from the enclosure or by providing auxiliary equipment for cooling, such as fans or air conditioning.

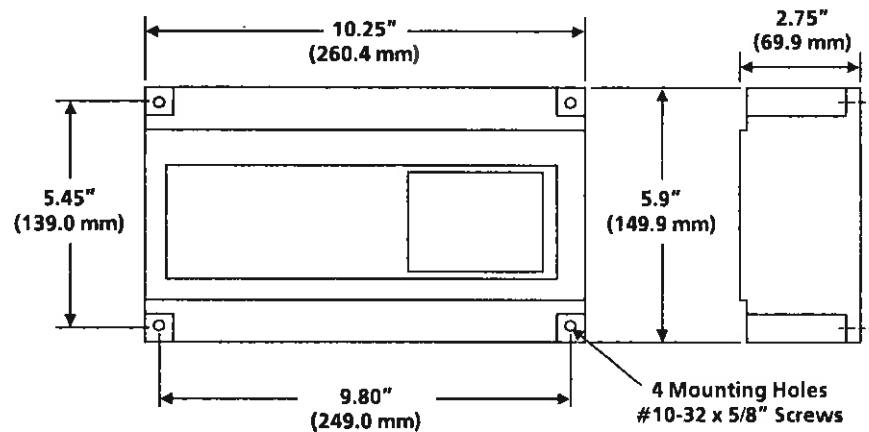

Removable Terminal Blocks – The wiring terminal blocks can be removed to allow replacement of a unit without removing power supply or I/O wiring.

To remove a terminal block, back out the two screws located at the ends of the terminal block. Alternate between the two screws, backing out about five turns at a time. This will help avoid binding. To replace the terminal block, align the terminal block screws with the holes on the chassis. Alternate between the two screws, as you did when removing the terminal block. Press on the center of the terminal block as you tighten the screws to help guard against an improper seat.

Connection Cables

Two cables are used for interconnecting processor and expansion units: Interconnect cable 1745-C3 is a 20-pin to 10-pin cable supplied with the SLC 150 processor unit. Interconnect cable 1745-C2 is a 10-pin to 10-pin cable supplied with each expansion unit. Both cables are 18.5 inches (47 cm) long. See the figure below for cable connector details.

Important: Do not use cables longer than those provided. Longer cables could affect the integrity of data communications between the processor and expansion units, possibly causing unsafe operation.

1745-C2 interconnect cable supplied with expansion units

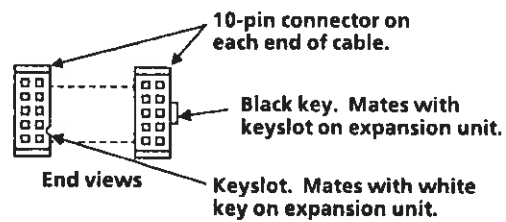

1745-C3 interconnect cable supplied with SLC 150 processor unit

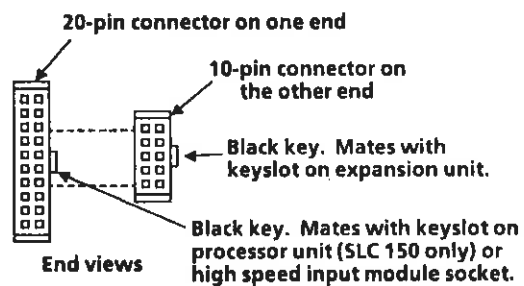

Connection Cables (continued)

The figure below explains how to install the interconnect cables.

A – Connecting expansion units to an SLC 150 processor unit

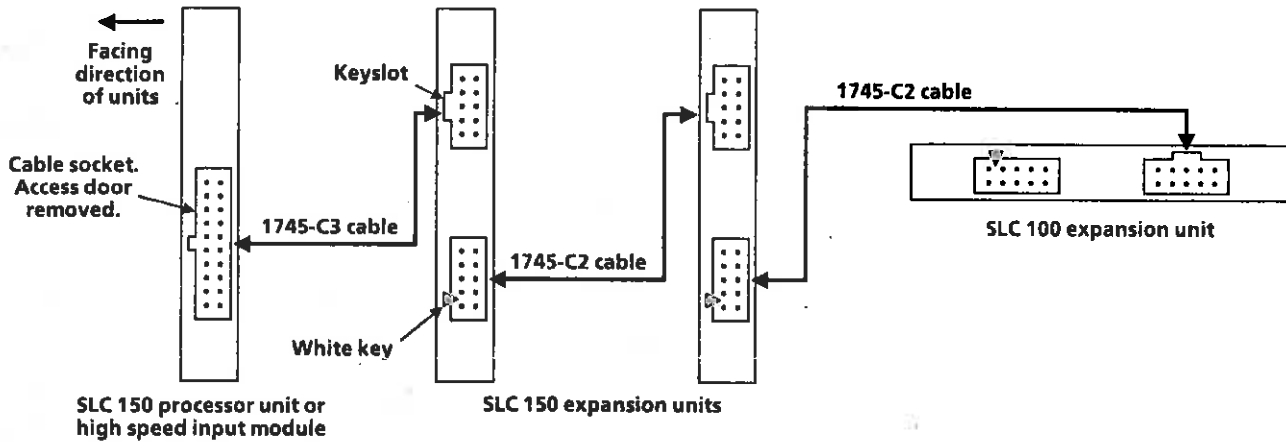

B – Connecting expansion units to an SLC 100 processor unit

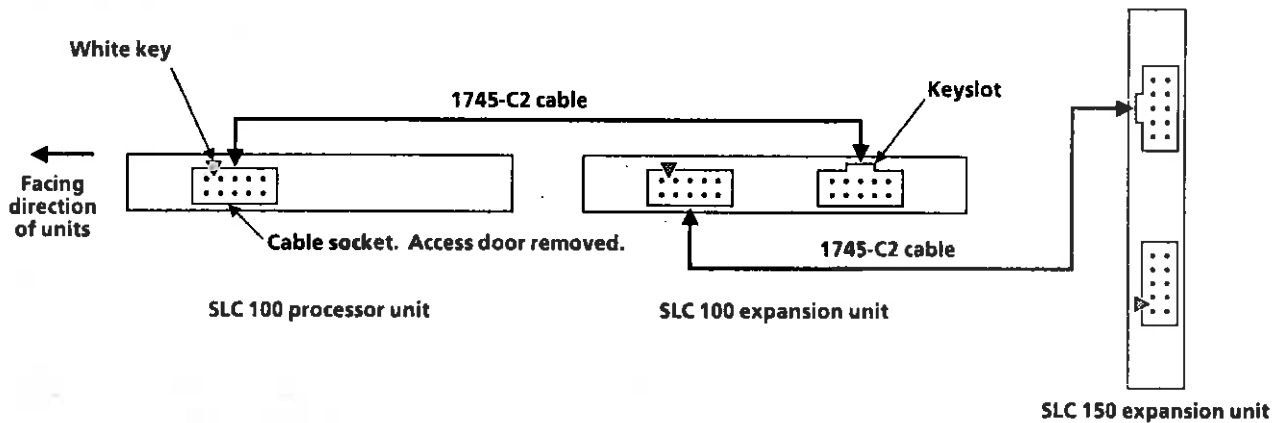

Connecting an expansion unit to an SLC 150 processor unit or high speed input module:

Use cable 1745-C3, supplied with the SLC 150 processor unit.

1. Open the access doors.
2. Refer to illustration A. Align the 20-pin cable connector with the socket on the processor unit (or high speed input module). Push gently; tabs will lock the connector in place.
3. Align the 10-pin connector with the expansion unit socket having the keyslot. Push gently; tabs will lock the connector in place.
4. Close the access doors.

Connecting an expansion unit to an SLC 100 processor unit:

Use cable 1745-C2, supplied with the expansion unit.

1. Open the access doors.
2. Refer to illustration B. Align the cable connector having the keyslot with the socket on the processor unit. Push gently; tabs will lock the connector in place.
3. Align the connector having the black key with the expansion unit socket having the keyslot. Push gently; tabs will lock the connector in place.
4. Close the access doors.

Connecting one expansion unit to another:

Use cable 1745-C2, supplied with the expansion unit.

1. Open the access doors.
2. Refer to illustrations A and B. Connect the cable to the expansion unit which is already connected to another unit. Note whether the unused socket has a keyslot or a white key. Plug in the appropriate connector.
3. Plug the remaining connector into the appropriate socket of the other expansion unit.
4. Close the access doors.

To remove cable: Move tabs on socket outward; the connector will pop out.

Line Wiring Connections

Make line connections to the processor unit as follows:

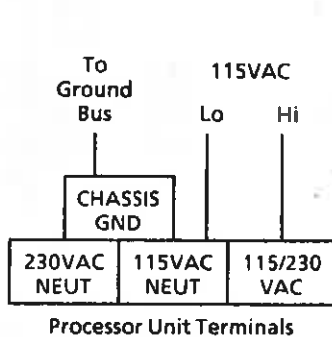

Catalog Nos. 1745-LP151, -LP152, -LP153

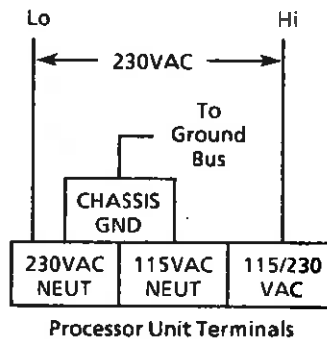

Note: An N.E.C. Class II power supply is required for UL listing.

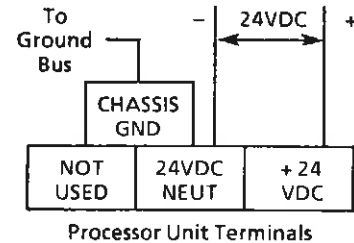

Catalog No. 1745-LP154

Power Supply Fuse Replacement

If the power supply fuse of the unit is blown, the DC Power indicator will not illuminate as it does during normal operation. The fuse could be blown because of excessive line voltage or because of an internal power supply malfunction.

After the conditions causing the malfunction have been corrected, the fuse can be replaced. The fuse compartment is located in the upper left corner, next to the incoming power wiring terminals.

WARNING: Contact with AC line potential can cause injury to personnel. Remove system power before removing the fuse compartment cover.

Replacement procedure:

1. Remove the fuse compartment cover.
2. Remove the fuse holder by pushing the handle to the left, then pulling outward.
3. Remove the fuse from its holder and replace it with a recommended replacement fuse.

CAUTION: Use only replacement fuses of the type and rating specified for the unit. Improper fuse selection may result in equipment damage.

4. Place the fuse holder back into its compartment by pushing inward until it locks into place. You may first have to shift the position of the wires.
5. Replace the fuse compartment cover.
6. Restore power. The DC Power indicator should now illuminate.

Input Device Wiring Connections

The diagrams below show typical input devices connected to the processor unit wiring terminals.

1745-LP151, -LP152

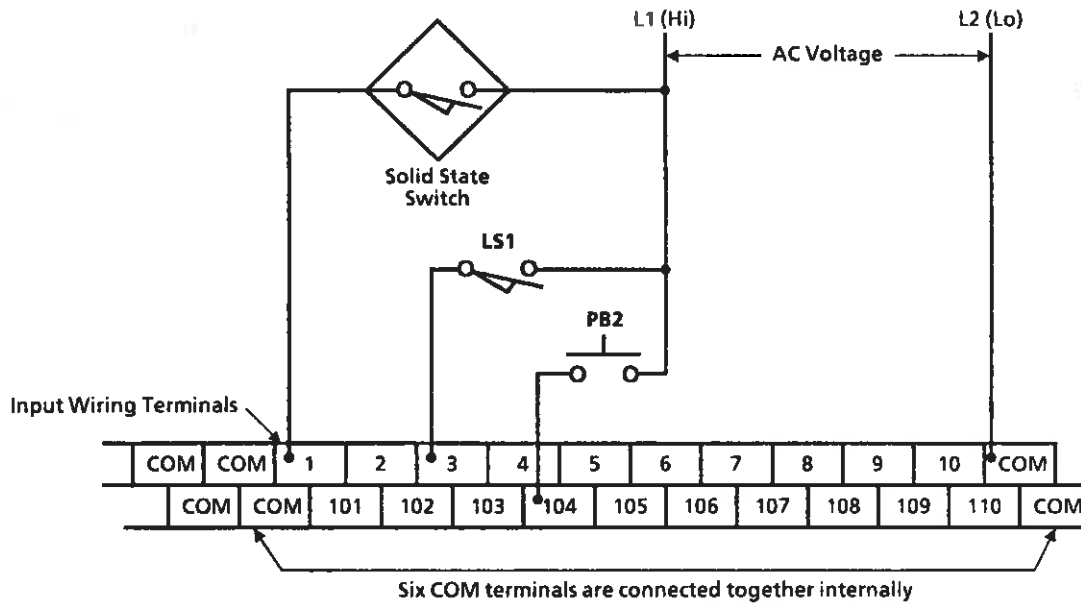

1745-LP153, -LP154

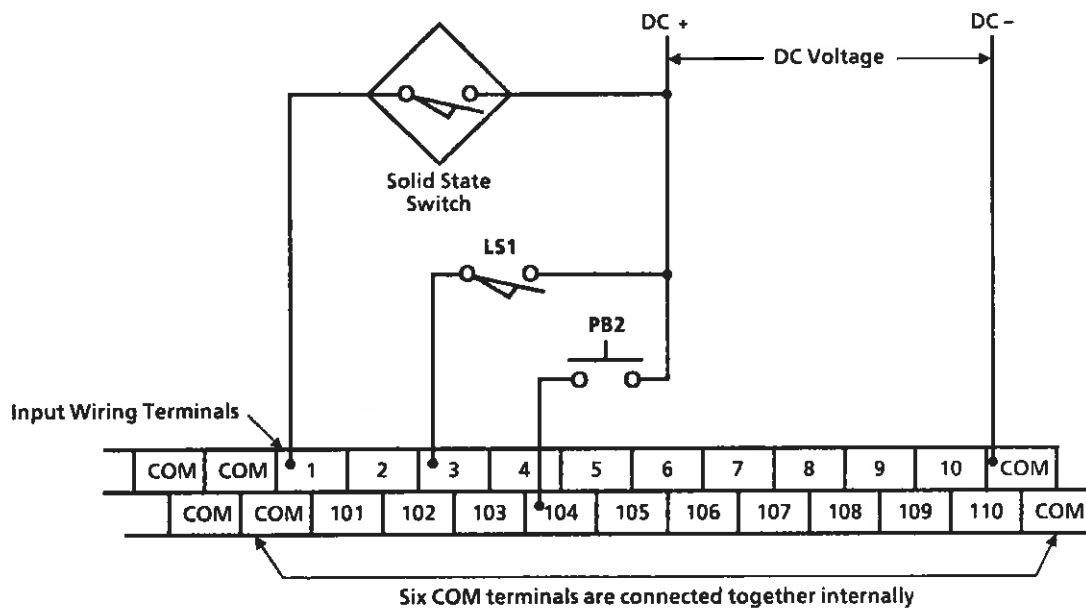

Output Device Wiring Connections

Wiring connections are shown below. Note that each processor unit has two isolated groups of outputs plus two additional isolated hard contact relay outputs.

Triac Outputs: Triac outputs include optical isolation as well as MOV protection to guard against possible damage by transients from external outputs. Triac output firing can be synchronized with the AC line to accomplish zero-cross turn on and minimize noise generated when switching loads. This is accomplished by making instruction `-(866)-TRUE` in the user program. If this feature is used, your scan time will be equal to 8.3 msec (or some multiple of) at 60 Hz and 10 msec (or some multiple of) at 50 Hz. Note that a common power source **must be used** for the processor unit power supply and output circuits to achieve zero-cross turn on.

Hard Contact Relay Outputs: Outputs at terminals 12-16 and 112-116 include arc suppression circuitry (RC networks) which protects contacts when switching inductive loads. We recommend that you also connect external surge suppression to protect the contacts from high transient voltage which occurs when an inductive device is switched off.

Hard contact relay outputs at terminals 11 and 111 do *not* include any internal arc suppression. Surge suppression is discussed on Page 13.

Transistor Outputs: These are sourcing type outputs with built-in optical isolation.

You should provide appropriate fusing to protect output devices and wiring from short circuits and overload conditions. Refer to the specifications on Page 17 for fusing recommendations.

1745-LP151, -LP152

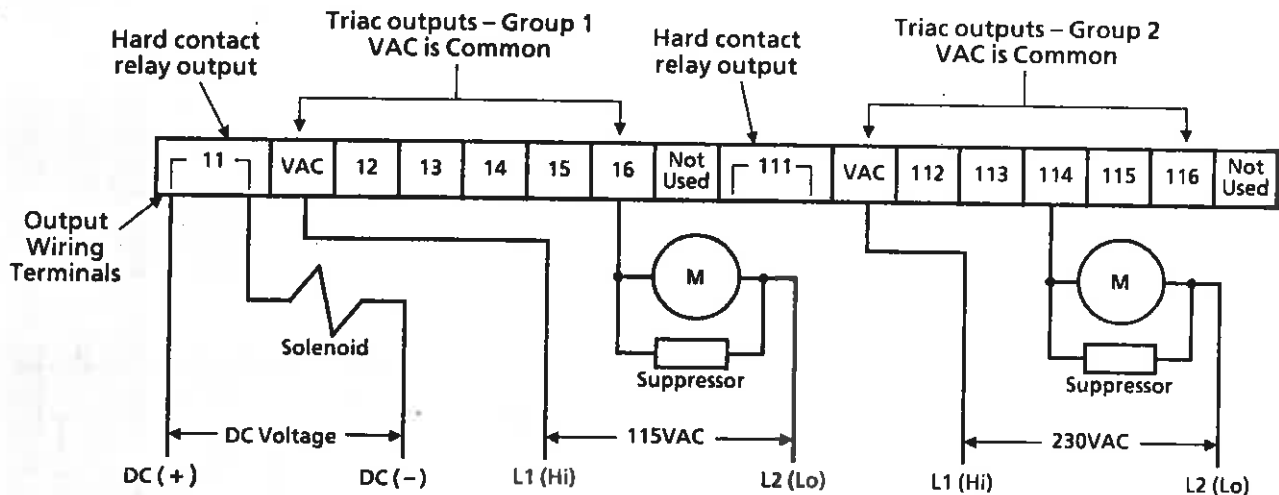

Processor Unit – SLC 150

Output Device Wiring Connections

(continued)

Wiring connections for processor unit catalog numbers 1745-LP153 and 1745-LP154 are shown below.

1745-LP153

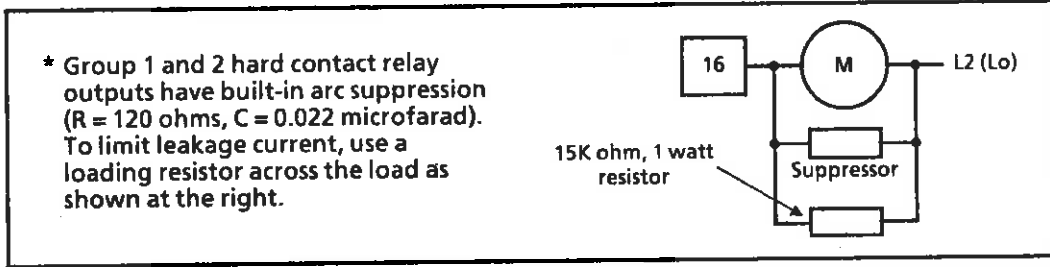
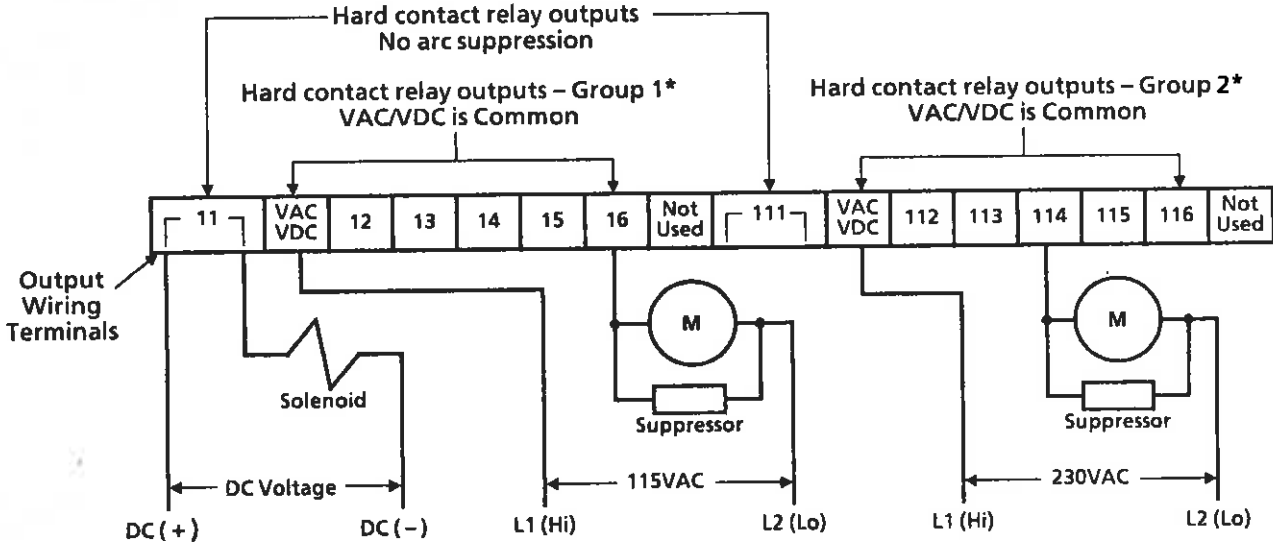

1745-LP154

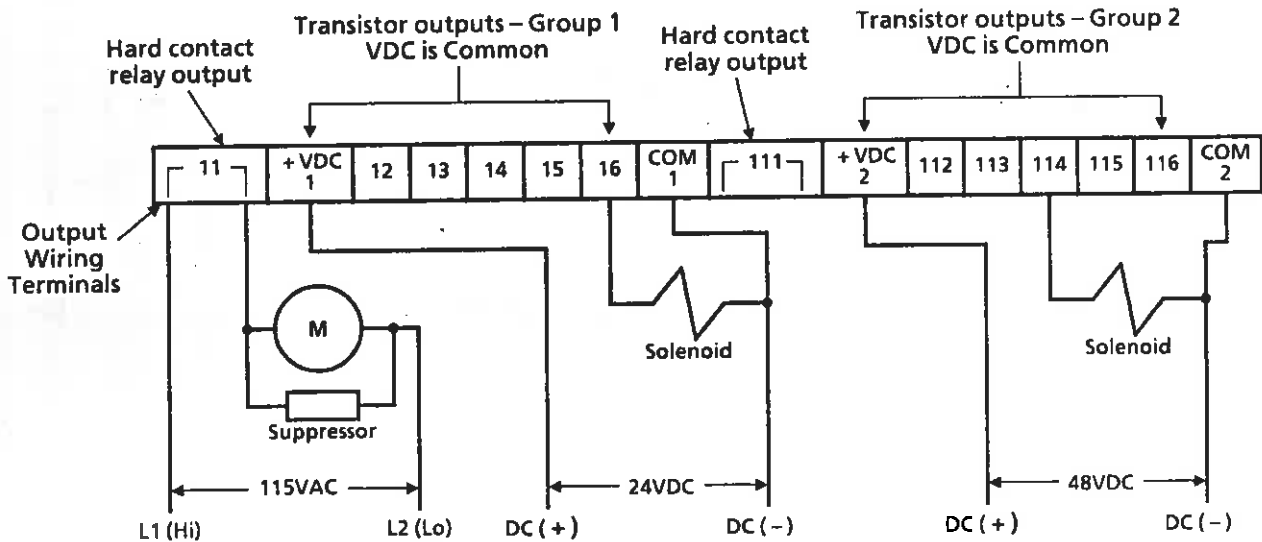

Surge Suppression

Inductive output devices such as motor starters and solenoids may require that you use some type of surge suppression to protect output contacts and minimize noise generation. Examples are shown below.

These surge suppression circuits are connected directly across the output device. The effect is to reduce arcing of the output contacts (arcing can be caused by the high transient voltage which occurs when an inductive device is switched off).

Suitable surge suppression methods for inductive AC output devices include a varistor, an RC network, and an Allen-Bradley surge suppressor. These components must be appropriately rated to suppress the switching transient characteristic of the particular inductive device.

For inductive DC output devices, a diode or a varistor is suitable. A 1N4004 diode is acceptable for most applications. A surge suppressor can also be used (Figure 18.4 in the SLC 100 Programmable Controller User's Manual).

We recommend that you locate the suppression device as close as possible to the output device.

Suppressors recommended for use with Allen-Bradley relays, contactors, and motor starters are listed in Figure 18.4 of the SLC 100 Programmable Controller User's Manual.

Surge Suppression for Inductive AC Output Devices

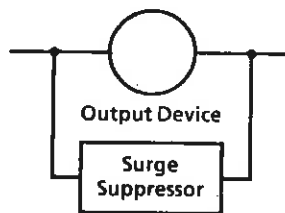
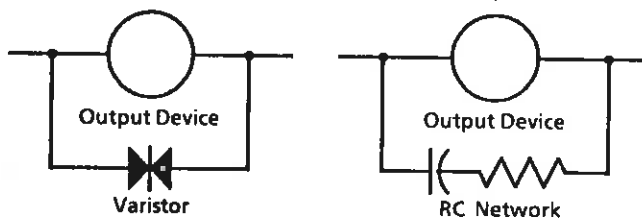

Surge Suppression for Inductive DC Output Devices

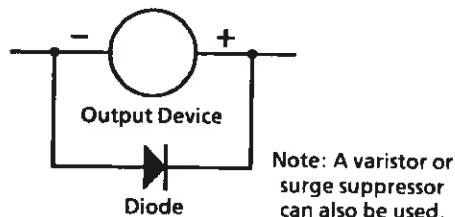

**CMOS RAM
Memory**

The standard SLC 150 Processor Unit comes equipped with a permanently installed capacitor that will provide back-up power to the RAM memory when power is removed from the processor unit. This capacitor can provide enough power to retain memory for 2 weeks at 30°C and 1 week at 60°C. The capacitor requires no maintenance since it is recharged to full strength whenever power is restored to the processor unit.

Note: If the processor unit is operated in temperatures above 50° C for extended periods of time, capacitor life cannot be guaranteed beyond 2 years. For these types of applications, we recommend using the optional Lithium battery for memory back-up.

The RAM memory provides 1200 words of user memory. Most instructions require 1 word.

**Optional Battery
Back-Up**

If you feel that you need to back-up your memory longer than the capacitor can provide, a Lithium battery can be used. This battery will provide back-up power to the RAM memory for a typical life of 2 to 3 years. Actual battery life may vary depending on controller environmental conditions.

**Battery Installation
or Replacement**

You can install or replace the battery without disconnecting power or disturbing normal operation of your machinery. Use the following procedures to install or replace the battery.

1. Remove battery compartment door from the front of the processor unit.
2. If you are **installing** a battery in a new processor unit (battery never installed before), unplug the battery connector and lead wires (red and white) by inserting your finger into the compartment and pulling up on the lead wires. If this cannot be done with a finger, you may wish to use a needle nose pliers to pull out the lead wires.
- 2a. If you are **replacing** an old battery, remove the battery assembly stored in the compartment. To do this, first pull up on the lead wires and remove them from the compartment. The battery is held in place by a small retainer clip on the right of the battery. Apply pressure on the left of the battery with a small screw driver or other small tool to push the battery against the clip while pulling the lead wires up at the same time. This will allow the battery to be pulled straight out of the compartment. Unplug female from male end of connector to disconnect old battery.
3. Connect a new battery making sure that the slot on the battery assembly connector aligns with the key of the processor unit socket.
4. Insert battery into compartment minus side first (white lead wire). Push the retainer clip to the side with the battery while inserting so that the battery will fall to the bottom of the compartment and stay in place with the clip.
5. Place battery connector and lead wires in compartment.
6. Replace compartment door.

General Specifications

General specifications for the processor unit are shown below.

Voltage Ranges (Incoming Power, Input Circuits, Output Circuits):

Catalog Number	Voltage Ranges (Incoming Power Connections)	External I/O		
		Input Circuits – 20	Output Circuits – 12	Color Code *
1745-LP151	85-132/170-265 VAC 50/60 Hz	85-132 VAC 50/60 Hz	10 Triac – 85-265 VAC 50/60 Hz 2 Hard Contact – 10-250VAC/10-125VDC	Red
1745-LP152	85-132/170-265 VAC 50/60 Hz	170-265 VAC 50/60 Hz	10 Triac – 85-265 VAC 50/60 Hz 2 Hard Contact – 10-250VAC/10-125VDC	Black
1745-LP153	85-132/170-265 VAC 50/60 Hz	10-30 VDC	12 Hard Contact – 10-250VAC/10-125VDC	Blue
1745-LP154	18-30 VDC	10-30 VDC	10 Transistor – 10-50 VDC 2 Hard Contact – 10-250VAC/10-125VDC	Green

* Color patch appears in the upper right corner of the unit, above the cluster of LED status indicators.

Maximum Power Requirement:

1745-LP151, -LP152, -LP153: 25 VA.
1745-LP154: 15 VA.

Input Power Fuse Protection:

1745-LP151, -LP152, -LP153: 315mA/250V.
1745-LP154: 1.6A/250V.

Fuse Types: SAN-O: SOC SD4.

Bussman: MDL, or GDC (miniature).

Hold-Up Time:

The processor can sustain operation for a minimum of 25 milliseconds in the event of a power interruption.

I/O Capacity:

20 inputs and 12 outputs. See table above.

Input specifications: Page 16.

Output specifications: Pages 17 and 18.

Specifications applying to all Catalog Numbers

Memory Type:

CMOS RAM with capacitor back-up (1-2 week memory back-up).

Optional Battery Back-up: Lithium battery, non-rechargeable, 2 to 3 year life.

User Memory Size: 1200 words max.
Most instructions require 1 word.

Typical Scan Time: 4 msec (1000 word program).

Specifications applying to all Catalog Numbers

Internal Relay Type Instructions:

177 max. (regular or latched).

Timers, Counters, Sequencers:

32 max, any combination, retentive.

Time Base:

0.1 sec. Fine Time bases down to 0.01 second can be selected.

Timer Range:

0.1 to 999.9 seconds.

Sequencer Capacity :

8 bits by 100 steps.

Shift Register: 8 bit groups.

Noise Immunity:

NEMA Standard ICS 2-230.

Vibration:

0.015 inch peak to peak displacement, 2.5g peak(max) acceleration, 1 Hr/axis.

Ambient Temperature Rating:

0° to 60° C (operating).
– 40° to 85° C (storage).

Humidity Rating:

5 to 95% (without condensation).

Wiring: #14 - #24 AWG stranded.
3/64" insulation (max).

Input Specifications

Input specifications are shown below. All input circuits include optical isolation as well as filtering to guard against high voltage transients from external input devices.

ON State Voltage Range and Frequency:

1745-LP151: 85-132 VAC, 47-63 Hz.
1745-LP152: 170-265 VAC, 47-63 Hz.
1745-LP153, -LP154: 10-30VDC.

Maximum OFF State Voltage:

1745-LP151: 30V.
1745-LP152: 50V.
1745-LP153, -LP154: 4V.

Maximum OFF State Leakage Current:

1745-LP151, -LP152: 2 mA.
1745-LP153, -LP154: 1mA.

Nominal Input Current:

1745-LP151, -LP152: 8 mA.
1745-LP153, -LP154: 4 mA at 12VDC, 8mA at 24VDC.

Input Filter Time ON Delay:

1745-LP151, -LP152: 3 to 13 msec.
1745-LP153, -LP154: 4 to 8 msec.

Input Filter Time OFF Delay:

1745-LP151, -LP152: 9 to 18 msec.
1745-LP153, -LP154: 4 to 8 msec.

Electrical-Optical Isolation:

1500 volts between input voltage and control logic. Applies to all catalog numbers.

Output Specifications

TRIAC OUTPUTS, 1745-LP151, -LP152 (Hard contact relay outputs: Page 18)

- Output Voltage Range:**
85-265 VAC.
- Continuous Output Current per Circuit:**
1A at 30°C, linearly derated to 0.5A at 60°C.
- Continuous Output Current per Chassis:**
10A at 30°C, linearly derated to 5A at 60°C.
- Surge Current:**
10A for 25 msec. Repeat once each second at 30°C, or once each 2 seconds at 60°C.
- Minimum Load Current:**
10 mA.
- Maximum OFF State Leakage Current:**
2 mA.
- OFF to ON Response Time (non-zero cross):**
0.1 msec (max).
- Zero-Cross Turn-on Timing Accuracy:**
± 500 microseconds.
- Saturation Voltage Drop:** 1.5 volts at 1.0A.
- Electrical-Optical Isolation:**
1500 volts between output voltage and control logic.
- Recommended Output Fusing:** San-O: SOC ST4-4A or equivalent.

TRANSISTOR OUTPUTS, 1745-LP154 (Hard contact relay outputs: Page 18)

- Output Voltage Range:**
10-50 VDC.
- Continuous Output Current per Circuit:**
1A at 30°C, linearly derated to 0.5A at 60°C.
- Continuous Output Current per Chassis:**
10A at 30°C. 5A at 60°C.
- Surge Current:**
3A for 20 msec. Repeat once each second at 30°C, or once each 2 seconds at 60°C.
- Minimum Load Current:** 1.0 mA.
- Maximum OFF State Leakage Current:** 0.1 mA.
- OFF to ON Response Time:**
100 microseconds.
- Maximum ON State Voltage Drop:**
1.5 volts at 1.0A. 0.8 volts at 0.5A.
- Electrical-Optical Isolation:**
1500 volts between output voltage and control logic.
- Recommended Output Fusing:** San-O: SOC ST4-2A or equivalent.

Output Specifications (continued)

Specifications for hard contact relay outputs are shown below. We recommend that you use some type of surge suppression when switching inductive load devices with hard contact outputs. Refer to Page 13.

HARD CONTACT RELAY OUTPUTS

Wiring Terminals, Internal Arc Suppression:

Catalog Number	Hard Contact Relay Outputs
1745-LP151 1745-LP152 1745-LP154	Units have 2 hard contact relay outputs, at terminals 11 and 111. These outputs do not have internal arc suppression circuitry.
1745-LP153	Units have 12 hard contact relay outputs. Relay outputs at terminals 12 thru 16 and 112 thru 116 have internal arc suppression circuitry. Relay outputs at terminals 11 and 111 do not have internal arc suppression circuitry.

Voltage Range and Frequency:
10-250 VAC (50/60 Hz), 10-125 VDC.

Contact Ratings:

Maximum Volts	Amperes		Amperes Continuous	Voltamperes	
	Make	Break		Make	Break
240VAC 120VAC	7.5A 15A	0.75A 1.5A	2.5A	1800VA	180VA
125VDC	0.22A		1.0A	28VA	
24VDC	1.2A		2.5A	28VA	

Contact Resistance:
20 mΩ (typical).

Electrical Isolation:
2000 volts between output contacts and control logic.

OFF State Leakage Current:
Outputs at terminals 11 and 111 (all catalog numbers):
No leakage current.

Outputs at terminals 12 thru 16 and 112 thru 116 of 1745-E153:
2mA (AC voltage only). To limit leakage current, use a loading resistor across the load as shown on Page 12.

**Processor Unit
Start-Up**

When power is applied to the SLC 150 processor unit for the first time, a processor fault will occur. The fault must be canceled and the processor RAM memory must be cleared to program and operate the processor unit. To cancel the fault and clear the RAM memory, connect the pocket programmer or a personal computer with SLC Personal Computer Software to the processor unit.

When you connect the pocket programmer to the processor unit, the programmer will display some error codes which identify the fault. These codes must be canceled individually by pressing the CANCEL CMD key after each code appears. When all error codes have been canceled, clear the processor memory by pressing MODE, 1, ENTER, ENTER. The processor RAM memory will be cleared and the processor will be placed in the Program mode.

If you are using a personal computer with the SLC Personal Computer Software, you will see an error message on the display and must use the program transfer function to clear the processor unit memory.

**User Program
Back-Up**

For maximum protection against user program loss or program alteration due to capacitor back-up drain, battery back-up drain, processor malfunction, or excessive noise, we suggest you install the EEPROM memory module. The EEPROM memory module (Cat. No. 1745-M1) plugs directly into the SLC 150 processor unit.

Refer to Publication 1745-810, Pages 5-6 for details on EEPROM operation with the SLC 150 processor unit. Refer to the SLC 100 User's Manual, Publication 1745-800, Page 21-5 for details on clearing user program error codes.

THERMOSWITCH®

Temperature Controllers

INSTALLATION INSTRUCTIONS

ATTENTION: TO ASSURE SAFE AND PROPER PERFORMANCE READ THESE INSTRUCTIONS.

GENERAL INFORMATION

The shell of each THERMOSWITCH unit contains the catalog number, the current rating, the temperature range and the contact arrangement.

The fifth digit of the catalog number describes whether contacts open or close on temperature rise. If contacts open on temperature rise (regular unit), the fifth digit of the catalog number is an even number such as 17000, 17002, etc. If contacts close on temperature rise (inverse unit), the fifth digit is an odd number such as 17021, 17023, etc.

UL Component recognized units will either have a "4" as the first digit (47002, etc.) or will bear the UL logo and utilize a 17000 series catalog number (17021, etc.).

If the fourth digit is other than "2" or "7" (such as 17021, 17071, etc.) it is compression operated. Inverse compression units are recommended if overshoots are to be encountered. Low temperature units can be overshoot to 500°F and high temperature units (-100 to 600°F) overshoot to 700°F for intervals not exceeding one hour.

INSTALLATION

Fenwal THERMOSWITCH® units are supplied in five basic head configurations - Cartridge, Block Head, Hex Head, Coupling Head and Circular Flange.

To avoid restricting shell expansion when making installations in solid metal blocks, a 5/8" diameter reamed hole for 5/8" units or a 13/16" diameter reamed hole for 13/16" diameter heavy duty units, is recommended. See specific controller style listing for additional installation instructions.

Cartridge [Style 1] (Includes moisture resistant high and low temperature units, A and C.) Hole should have short spline to receive the 1/8" diameter locating pin. This prevents the unit from rotating when the adjusting sleeve is turned. It may also be used for surface control if inserted into a Fenwal surface mounting block (Cat. No. 11100-2).

Block Head [Style 2] - is mounted in a similar manner to the cartridge type. If the unit is to be inserted into a reamed hole, two short pins should be mounted on either side of the hole. The pins should rest against the sides of the block head to prevent rotation of the unit.

Hex and Coupling Head [Styles 3 and 4] - can be installed like any pipe fitting. See Table 1 for maximum torque value.

Circular Flange [Style 5] - Three holes in flange allow for easy mounting on any flat surface.

NOTE: If the threaded units are installed in a pipe tee, the tee should be large enough to allow adequate circulation of the fluid around the temperature sensitive section of the unit.

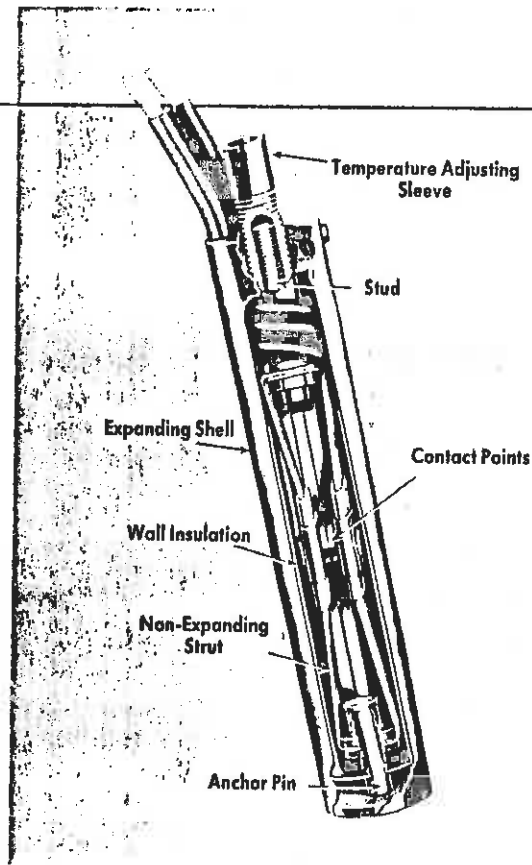

NOTE: Certain gases or liquids including water at elevated temperature could be corrosive and may also cause electrolytic action, which could severely shorten the life of the controller.

The rate of corrosion or electrolysis is influenced by a great many system parameters such as chemical makeup and temperature of the solution, stray electric currents, etc. Consult the supplier of your chemicals or the factory for suggestions.

TABLE I - Torque

Max. Torque	THERMOSWITCH® Controller Types
35 ft. lbs.	5/8" Dia. Standard with N.P.T. *
70 ft. lbs.	13/16 Dia. Heavy Duty with N.P.T. **

* 4 ft. lbs.	When Teflon tape lubricant is used.
**8 ft. lbs.	

WARNING: Excessive torque may change temperature settings.

CAUTIONS!

- DO connect THERMOSWITCH controller leads in series with the load and power supply.
- DO be certain that there is sufficient but not excessive room for the installed THERMOSWITCH unit to expand in diameter and length.
- DO use stainless steel heliarc welded thermowells, (Series 11100, 11200) or various platings which, may increase controller life where corrosion or electrolysis is suspect.
- DO insulate head of the THERMOSWITCH unit where large external temperature variation may occur. This precaution is not necessary on the junction box type. (Series 17700, 17800).
- DO prevent internal damage by mechanically presetting regular tension units (those with catalog number containing fourth digit other than 2 or 7) to approximate required elevated temperature before inserting into process. Preset by turning adjusting sleeve counterclockwise following the adjustment rate information shown on Table II, Page 2.

MOUNTING STYLES

Moisture Resistant Units

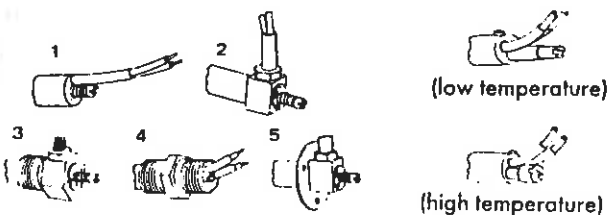

CAUTIONS (Continued)

- DON'T** immerse your unit in liquids or vapors unless it was specified for that job.
- DON'T** seal head with silicone materials.
- DON'T** exceed the ratings indicated on THERMOSWITCH unit shell.
- DON'T** thermally shield unit from medium being controlled.
- DON'T** remove adjusting screw or turn adjusting screw in farther than necessary for desired operation. This action may permanently damage the unit and may void standard Fenwal warranty!
- DON'T** oil your unit. Oil around adjusting screw will flow inside, contaminating contacts.
- DON'T** allow moisture buildup in head cavity area of 37X0X0-000 Moisture Resistant Units. Where excessive moisture is a problem, specify Special Feature 01-982039-00X when ordering.
- DON'T** try to repair unit yourself.
- DON'T** handle unit with pliers or force it into position either by hand or tools, or apply excessive torque in tightening threaded units.
- DON'T** subject shell of unit to deformation.
- DON'T** over-torque threaded units.

TESTING AND ADJUSTMENT



The arrow on the head of THERMOSWITCH unit indicates direction to turn adjusting screw to increase temperature setting. Torque in excess of 15 inch pounds on adjusting sleeve will deform slot.

Each full turn of adjusting sleeve will change temperature the approximate number of degrees as follows:

TABLE II – Adjustment Rates for Thermostat Units

TENSION OPERATED		COMPRESSION OPERATED	
Catalog Series Number	Approx. F° per full turn of adj. sleeve	Catalog Series Number	Approx. F° per full turn of adj. sleeve
—	—	13121-1	1000
15050 to 16051	165	—	—
17000 to 17503	90-115	17020 to 17523	90-100
17700 to 17701	145	17720 to 17721	85
17702 to 17703	180	17722 to 17723	100-150
17800 to 17801	125	17820 to 17821	75
17802 to 17803	160	17822 to 17823	115
18000 to 18003	80-100	18020 to 18023	70-135
01-37X0X0-000	90		

After the THERMOSWITCH unit has been installed, final adjustment can be made by allowing the unit to operate for several cycles to permit the controlled system to stabilize and then adjust to desired temperatures. The system should then be cooled to ambient temperature, reheated and stabilized to check the setting.

To adjust a high temperature moisture resistant THERMOSWITCH unit (Cat. No. 01-370020-000) it is necessary to remove the seal cap. A screwdriver adjustment is then made internally. Use caution when making adjustments at temperature extremes.

Where extremely accurate temperature control is desired several readjustments may be necessary to stabilize the THERMOSWITCH control after which the adjustment will be maintained.

CONTACT PROTECTION

Capacitors are not required under average conditions. For smoother control at small loads, on D.C. applications or to prevent contact bounce due to vibration, the following table is recommended as a guide:

TABLE III – Contact Protection

VOLTAGE	SERVICE	CAPACITANCE MFD (non-polarized)
120VAC	Resistance	Non required
240VAC	Resistance	.1
120 or 240VAC or DC	Relays, Magnetic Contactors	.001 to .01
15-25VAC or DC	Relays	.02
120 or 240VAC	Motor	Use Relay

NOTE: Capacitors should be wired in parallel with thermostat lead connections. Capacitors should be rated for a minimum of 600VDC with 120VAC circuits and a minimum of 1000VDC for 240VAC circuits.

TESTING TEMPERATURE SET POINT

The **Set Point Temperature** is the temperature at which the contacts on a THERMOSWITCH unit just "make" (close). All THERMOSWITCH units are set at room temperature (75°F ± 15°F) unless otherwise specified in which case they are factory preset at any specified temperature within listed temperature range and setting tolerance of THERMOSWITCH unit.

If customer requires testing of temperature set point, it is recommended that testing devices can be used similar to those at the factory. An ideal thermal installation may require that the THERMOSWITCH unit be located as near as possible to the heat source. Testing the temperature set point of a THERMOSWITCH unit in an application or under conditions where heat source is remotely located from THERMOSWITCH unit, or when ambient temperature conditions are far below or above 75°F, may give misleading results. In some cases, this has led to rejection of units which were actually within proper setting tolerance. Therefore we recommend the use of a Fenwal Model 80001-0 Test Kit, for testing temperature set points on Fenwal THERMOSWITCH units.

For customers who wish to build their own test equipment we recommend that you contact your nearest Fenwal Representative. He is equipped to give you further guidance in setting up a good thermal test system.

LIMITED WARRANTY STATEMENT

Fenwal Incorporated represents that this product is free from defects in material and workmanship, and it will repair or replace any product or part thereof which proves to be defective in workmanship or material for a period of twelve (12) months from the date of purchase but not to exceed eighteen (18) months after shipment by the seller. For a full description of Fenwal's LIMITED WARRANTY, which among other things, limits the duration of warranties of MERCHANTABILITY and FITNESS FOR A PARTICULAR PURPOSE and EXCLUDES liability for CONSEQUENTIAL DAMAGES, please read the entire LIMITED WARRANTY on the Fenwal Quotation, Acceptance of Order and/or Original Invoice which will become a part of your sales agreement. Defective units should be returned to the factory, Ashland, Massachusetts, shipment prepaid. Fenwal Incorporated will repair or replace and ship prepaid.

FENWAL INCORPORATED

Division of Kidde, Inc.

KIDDE

400 Main Street Ashland, Massachusetts 01720 (617) 881-2000

1.10.S 100M 11/86 Printed in U.S.A.

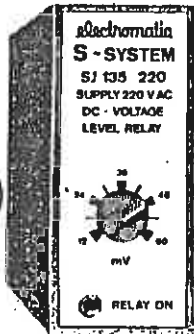

SJ 135



- * DC voltage metering relay with absolute scale.
- * Measuring range: 12 mV - 500 VDC, divided into 10 ranges.
- * Knob-adjustable set point.
- * Latching at set level possible.
- * 10 A SPDT output relay.
- * LED-indication: relay on.
- * AC or DC power supply.

SJ 135 =
11-pin circular plug

SPECIFICATIONS

The common technical data

Measuring ranges

Ranges	Internal resistance	Max. voltage	YYYYY
12 - 60 mV	100 Ω	1 V	60 mV
30 - 150 mV	150 Ω	2 V	150 mV
0.2 - 1 V	1 KΩ	10 V	1 V
1 - 5 V	3 KΩ	30 V	5 V
2 - 10 V	10 KΩ	50 V	10 V
4 - 20 V	20 KΩ	100 V	20 V
10 - 50 V	51 KΩ	150 V	50 V
30 - 150 V	150 KΩ	350 V	150 V
60 - 300 V	300 KΩ	500 V	300 V
100 - 500 V	510 KΩ	600 V	500 V

Hysteresis

Approx. 10%.
The hysteresis can be extended to approx. 75% by connecting a suitable resistor between pins 8 and 9.
Resistor limits are 470 KΩ/3 KΩ (0.25 W).
The hysteresis increases by decreasing resistance.

Latching

By interconnecting pins 8 and 9 the relay will latch at set level until either the power supply or the interconnection is interrupted.

Ordering key

11-pin circular plug.
SJ 135 XXXYYYYY -- 10 A SPDT
XXX = power supply
024 = 20-28 VAC
115 = 95-135 VAC
230 = 195-265 VAC
724 = 20-28 VDC

YYYYY: See measuring ranges.

Accessories

Bases.
Hold down spring.
Mounting rack.
Base covers.
Front mounting bezel.

WIRING DIAGRAMS

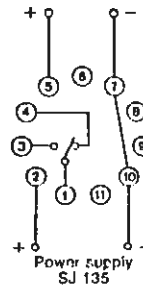
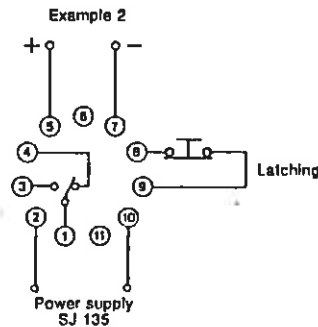
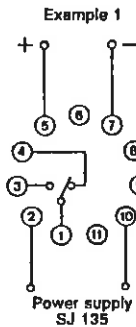

Note:
Internal connection between pins 7 and 10 at DC power supply. No current is to pass through this internal connection.

MODE OF OPERATION

Example 1

DC voltage metering. (AC power supply).

The relay will operate when the actual voltage equals the set value.
The relay releases when the voltage drops min. 10% below the set value (see hysteresis) or when the power supply is interrupted.

Example 2

DC voltage metering. Latching. (AC power supply).

The relay will operate and remain in operating position when the actual voltage equals the set value.
Provided that the voltage has dropped min. 10% below the set value (see hysteresis), the relay will release when the interconnection between pins 8 and 9 is interrupted.
The relay also releases when the power supply is interrupted.

OPERATION DIAGRAM

Example 1

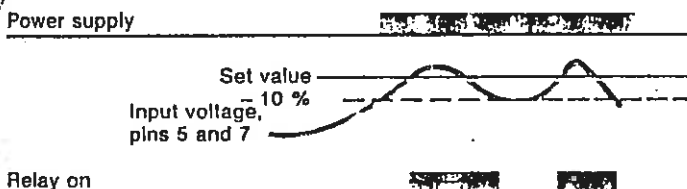

Example 2

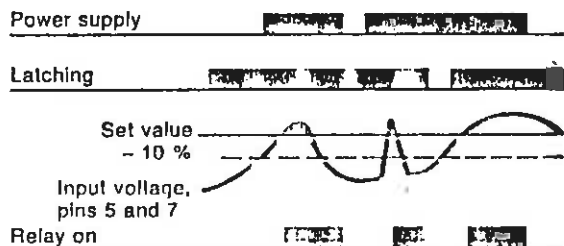



MAINTENANCE INSTRUCTIONS

STANDARD REDUCERS SERIES 133, 175, 206, 262, 325

INDEX

	Page
Introduction	1
Equipment Required	1
General Instructions	1
Housings	1
Seals	1
To Change Output Shaft Direction	1
Unit Disassembly, Parts Service, and Reassembly	1
Disassembly	1
Low Speed Shaft Removal	1
High Speed Shaft Removal	1, 2
Parts Service	2
Housing	2
Seal Cages and End Cover	2
Air Vent	2
Seals	2, 3
Bearings	3
Worm Gear and Shaft	3
Unit Reassembly	4
High Speed Shaft Assembly	4
Low Speed Shaft Assembly	4
Preventive Maintenance	6
Stored and Inactive Units	6
Parts Ordering Instructions	6
Exploded Views	7, 8, 9
Parts List	9
Warranty	Back Cover

MAINTENANCE INSTRUCTIONS FOR STANDARD REDUCERS

Series 133, 175, 206, 262 and 325

INTRODUCTION

The following instructions apply to standard Worm Gear Reducers. When ordering parts or requesting information specify all information stamped on the reducer nameplate. The nameplate will also identify the type of lubricant to be used.

EQUIPMENT REQUIRED

In addition to standard mechanic's tools, the following equipment is required: arbor press, wheel puller, torque wrench, dial indicator, seal driver, bluing, Permatex No. 2 and Permatex No. 3, snap ring pliers for internal and external rings.

GENERAL INSTRUCTIONS

Housings — Clean external surfaces of reducer before removing seal cages and end covers to prevent dirt from falling into the unit. Record mounting dimensions of accessories for reference when reassembling. If it is necessary to remove the reducer from its operating area, disconnect all connected equipment and lift reducer from its foundation.

Seals — Replacement of all seals is recommended when a unit is disassembled. However, if seals are not to be replaced, protect seal life by wrapping shaft with thin, strong paper coated with oil or grease before removing or replacing seal case assembly. Clean the shaft but do not use any abrasive material on the shaft surface polished by the seal.

CAUTION

If the reducer is painted, extreme care should be taken to mask the shaft extensions and rubber surface of the seals. Paint on the shaft adjacent to the seal or on the seal lip will cause oil leakage.

TO CHANGE OUTPUT SHAFT DIRECTION

To change the hand of a unit from left hand to right hand, or vice versa, the following instructions apply:

1. Remove drain plug and drain oil from unit.
2. Remove end cover and seal cage cap screws; then while supporting output shaft remove end cover and shims from the unit.
3. Remove output shaft and seal cage together from extension side.

NOTE: Keep shims with their respective seal cage and end cover.

4. Insert seal cage, shims and sub-assembly into the housing from the side opposite from which they were removed. Insert seal cage cap screws and tighten with light pressure.
5. Assemble end cover and shims. Insert end cover cap screws and tighten with light pressure.
6. Turn high speed shaft in both directions to see that gear train is running freely.
7. Cross tighten seal cage and end cover cap screws to torques listed in Table 1.

TABLE 1. CAPSCREW TIGHTENING TORQUE

Capscrew Diameter	1/4 - 20 UNC	5/16 - 18 UNC	3/8 - 16 UNC
Torque (in. lbs.) Dry	96	204	360

UNIT DISASSEMBLY, PARTS SERVICE, AND ASSEMBLY

Disassembly:

1. Remove drain plug and drain oil from unit.
2. Low speed shaft (gear shaft) removal:
 - A. Remove end cover and seal cage cap screws.
 - B. With a firm hold on the output extension remove end cover and shims.
 - C. Carefully slide output shaft assembly and seal cage out extension side.
 - D. Slide seal cage off low speed shaft using caution to prevent damage to seal lips.
 - E. Wire or tie the shims to their mating end cover and seal cages. They will be available for reference when assembling the unit.
3. High speed shaft (worm shaft) removal:
 - A. Position unit with input shaft down. With a small chisel make a groove in the stamped steel cover opposite the shaft extension. Pry cover off.

- B. Remove internal snap ring from housing bore.
- C. Reposition the housing with the worm shaft horizontal. Using a plastic hammer gently tap on the end of the shaft extension to feed worm shaft assembly through housing and out.

Parts Service:

- 1. **Housing** — Clean inside of housing with kerosene or solvent and then dry.
- 2. **Seal cages and end cover** — Remove dirt from joint faces, wipe clean and dry.
- 3. **Air vent** — Wash in kerosene, blow clean and dry.
- 4. **Seals** — To replace seals without dismantling reducer refer to steps C through F below. To replace seals when the entire reducer is dismantled and coupling hubs, sprockets, pulleys, pinions, keys, etc. have been removed the following instructions apply:

NOTE: Replacement of all seals is recommended when a unit is disassembled.

Caution

New seals will leak if the seal lips or if seal's rubbing surface on the shaft has been altered. Protect seal lips at all times. Clean the shaft but do not use any abrasive material on the shaft surface polished by the seal.

- A. Block up seal cages and press or drive out seal.
- B. Remove old sealing compound from seal seat in cage if it is present. If a seal with rubber coating on the outside diameter is used, no Permatex is necessary. If no rubber coating is on seal outside diameter, coat seal cage bore with Permatex No. 3 or equivalent immediately before assembly. To prevent possible damage to seal lips, do not reassemble seals until high speed and low speed shafts have been reassembled to the housing. Then see steps E and F below.
- C. See Figures 1 through 4—To replace seals without dismantling reducer, proceed as follows:

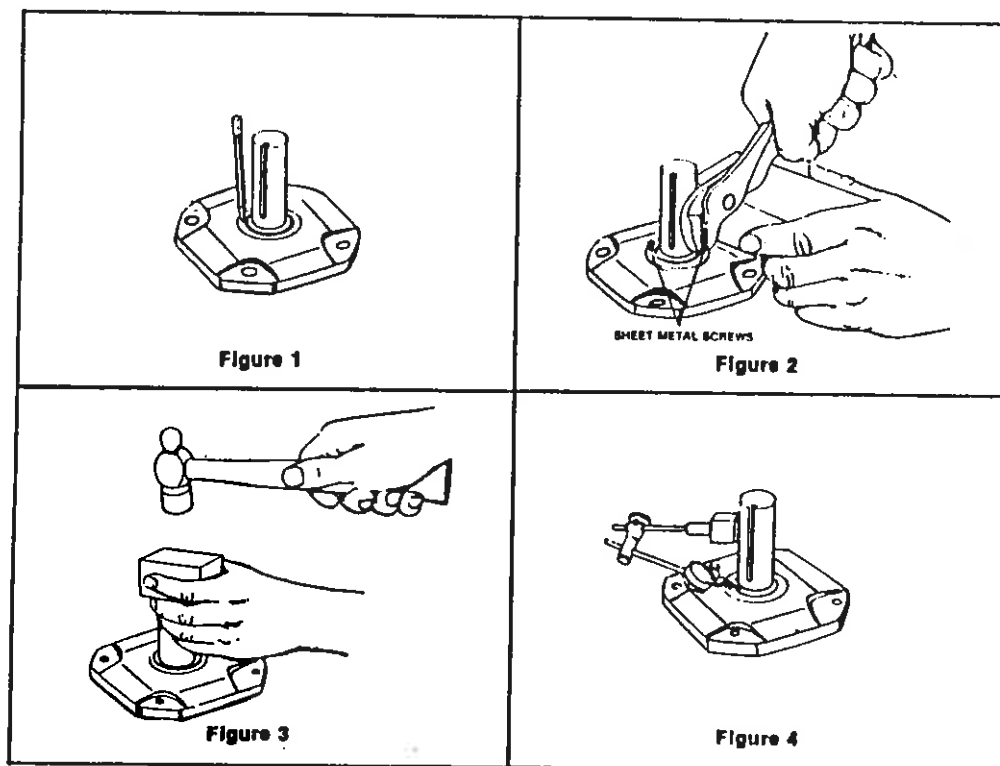

Caution

Do not damage shaft; new seals will leak if seal contacting surface is marred. Use punch and place two or more holes in steel casing of seal, Figure 1. (The steel casing may be rubber coated) Insert sheet metal screws, leaving the heads sufficiently exposed so they can be pried up or grasped with pliers, Figure 2. Do not drill holes because chips may get into the unit.

- D. Work seal loose. Be careful to keep all metal or dirt particles from entering unit. Remove old sealing compound from seal seat if it is present. Also remove burrs and sharp edges from shaft. Clean with rag moistened with solvent. Do not use abrasive material on shaft seal contacting surface.

Caution

- E. Protect seal lips when handling; seal leakage will result if these are damaged. If a seal with rubber coating on the outside diameter (O.D.) is used, no Permatex is necessary. If no rubber coating is on seal O.D., coat seal cage bore with Permatex No. 3 or equivalent. Coat seal lips with oil and carefully work seal into position. Before sliding seal into position, protect seal lips from shaft keyway edges by wrapping shaft with thin, strong paper coated with oil. Position garter spring toward the inside of the unit. Place a square faced pipe or tube against the seal O.D. and drive or press seal until fully seated as shown in Figure 3: Do not strike seal directly.

- F. For best performance, seat the seal square with shaft within .005" at 180°. Check with dial indicator as shown in Figure 4, Page 2, or with a straight edge and feelers, or square and feelers. To straighten a cocked seal, place tubing over the seal and tap the tube lightly at a point diametrically opposite the low point on the seal. DO NOT strike seal directly.

5. Bearings —

- A. Wash all bearings in clean kerosene and then dry.
B. Inspect bearings carefully and replace those that are worn or questionable.
NOTE: Replacement of all bearings is recommended.
C. Use a wheel puller or press to remove worm shaft bearings. Apply force to inner race only — not to cage or outer race.
D. Use a wheel puller or press to remove output bearing inner races.
E. New seal cages and end covers must be used when replacing output bearings. Output bearing outer races must be pressed in square and seated completely.
F. To replace output bearing inner races and all input bearings, heat bearings in an oil bath or oven to maximum of 290 degrees F (143 degrees C). Slide high speed shaft bearings onto the oiled shaft until seated against the shoulder or snap ring of the shaft. Slide low speed shaft bearings onto the oiled shaft against the gear spacer.
G. Thoroughly coat all bearings with lubricating oil.

6. Worm, gear and shafts

- A. Worm and high speed shaft—since all worms are integral with the high speed shaft, any wear or damage to the worm will necessitate replacing both.
B. Press shaft out of bronze worm gear. To reassemble gear and low speed shaft, freeze shaft or heat gear. Do not exceed 200 degrees F (93 degrees C). Insert key into shaft keyway and press shaft into oiled gear bore. The short hub of the gear must be assembled toward snap ring on the shaft.
NOTE: It is advisable to replace both the worm and worm gear should either of the assemblies require replacement.

Unit Reassembly:

1. Preliminary

- A. Check to see that all worn parts have been replaced, gear and bearings coated with oil and all parts cleaned. Remove all foreign matter from unit feet. The feet must be flat and square with each other.
- B. Before starting to reassemble reducer, add old shims or replace with new shims of equal thickness.

2. High Speed Shaft (Worm Shaft) Assembly

- A. Lubricate bearing bores of housing and insert high speed shaft sub-assembly from opposite extension end into housing until seated against shoulder in bore. Tap the end of the shaft lightly with a plastic hammer to feed bearings through bores.
- B. Lock high speed sub-assembly in housing bore with lock ring.
- C. Coat outside diameter of stamped steel end cover with Permatex No. 2 and press into high speed bore opposite extension end until flush with housing. If steel endcover is rubber coated then no Permatex is necessary.

3. Low Speed Shaft (Gear Shaft) Assembly

- A. Determine output shaft direction.
- B. Assemble low speed shaft assembly, seal cage, and end cover with shims on both seal cage and end cover. Torque cap screws to torques listed in Table 1. Rotate the input shaft to seat output bearings.
- C. Moving the shaft back and forth by hand, check axial float with dial indicator as shown in Figure 5. Axial float must be .0005-.003 with .0005 being the absolute minimum. Do not preload bearings. If the axial float is not as specified add or subtract required shims under end cover.

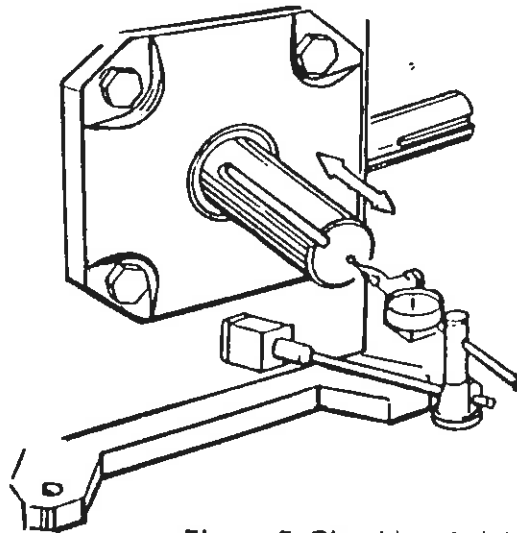

Figure 5 Checking Axial Float

- D. Remove output shaft with seal cage and apply bluing to entire worm thread. Worm thread must be clean of oil. Reassemble output shaft and seal cage with output key facing up.
- E. Use a rag to apply hand pressure to the output shaft and rotate the high speed shaft until output key is down. Return output shaft to original position by reversing rotation. Remove output shaft and seal cage to inspect contact. Compare with Figure 6. If contact is not correct move assembly in the direction shown in Figure 6 by adding shims to the side to which the arrow points after removing them from the opposite side. Repeat steps D and E until contact pattern is correct.
- F. Recheck axial float with dial indicator.
- G. When contact pattern is correct tighten seal cage and end cover cap screws to torques listed in Table 1 page 1.

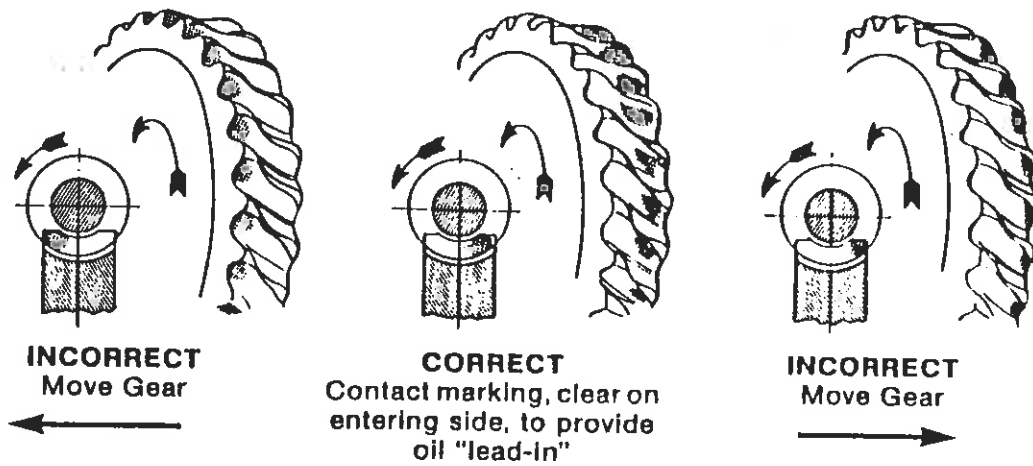

Figure 6 Gear Contact Pattern

4. **Seals** — To reassemble seals to unit, see Parts Service Steps 4E and 4F, page 3.
5. **Motorized Coupling Adapter**
 Certain mounting dimensions should be adhered to when removing motor and coupling assembly for service. When ordering replacement coupling halves (metal gear), specify correct bore diameter. See Table 2 for mounting dimensions and available bore sizes.

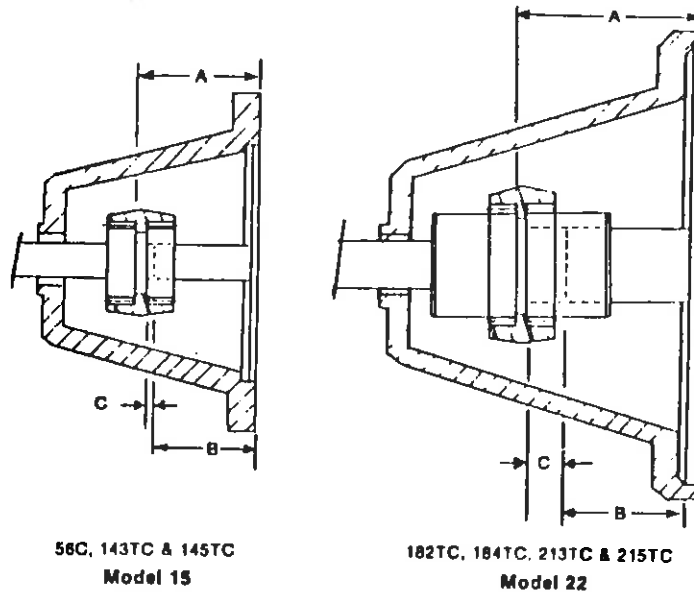

Figure 7 Motorized Coupling Adaptor

TABLE 2. COUPLING ADAPTOR DATA

"C" COUPLING MOUNTING DATA

N.E.M.A. Frame No.	Mounting Dimensions		
	Reducer A ± 1/64	Motor B ± 1/64	C
56C	2 5/16	2 1/16	1/16
143TC	2 5/16	2 1/8	—
145TC	2 5/16	2 1/8	—
182TC	3 5/16	2 5/8	1/2
184TC	3 5/16	2 5/8	1/2
213TC	3 5/16	3 1/8	—
215TC	3 5/16	3 1/8	—

BORE SIZES AVAILABLE

MODEL 15		MODEL 22	
Bore	Kwy.	Bore	Kwy.
.500	None	—	—
.500	1/8 x 1/16	—	—
.625	3/16 x 3/32	.625	3/16 x 3/32
.750	3/16 x 3/32	.750	3/16 x 3/32
.875	3/16 x 3/32	.875	3/16 x 3/32
—	—	1.125	1/4 x 1/8
—	—	1.375	5/16 x 5/32

6. Final Inspection

- A. Turn gear train over by hand as a final check.
- B. Re-install reducer and accessories.

CAUTION: Discard motor key. Use only special key provided with reducer. Failure to use special key will make assembly impossible.

- C. Fill reducer with the recommended oil to proper level. See Fig. 8 for standard oil levels. (Type of oil recommended — see nameplate).
- D. Spin test for three minutes and check for noise, leakage, and rapid temperature rise.

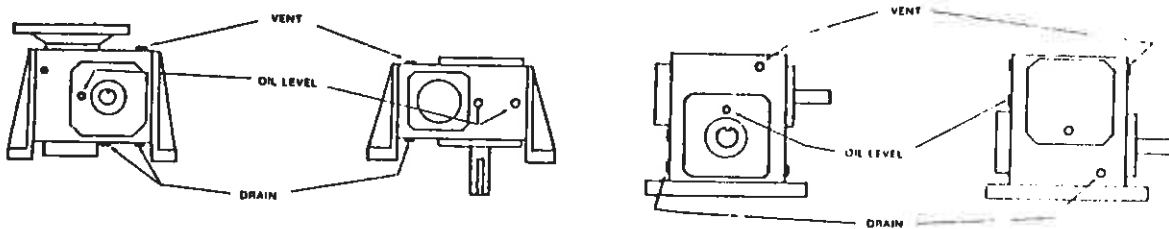

Figure 8 Standard Oil Levels

PREVENTATIVE MAINTENANCE

- A. After first week check all external cap screws and plugs for tightness.
- B. Periodically, check oil level when gears are at rest. Add oil if needed. Do not fill above mark indicated by level because leakage and overheating may occur.
- C. Oil changes — For normal operating conditions, change oil every six months or 2500 hours, whichever occurs first. Also if the unit is operated in an area where temperatures vary with the season, change the oil viscosity to suit the temperature. Most lubricant suppliers can test oil periodically and recommend economical oil change schedules.

CAUTION

See nameplate for type of lubricant to be used.

STORED AND INACTIVE UNITS

1. Each unit is shipped with oil that will protect parts against rust for a period of 4 months in an outdoor shelter or 12 months in a dry building after shipment from the factory. Indoor dry storage is recommended.
2. If a unit is to be stored or is to be inactive after installation beyond the above periods, fill the unit completely with oil.

CAUTION

Before starting a stored unit or re-starting an inactive unit, the oil level should be returned to the proper value as indicated by the oil level.

PARTS ORDERING INSTRUCTIONS

When ordering replacement parts first locate the exploded view that corresponds to your Doerr Electric gear reducer. Then determine which parts must be ordered. To order the parts, please provide the following:

1. Complete Model Number (Nameplate)
2. Item Number (Exploded view and parts list)
3. Part Description (Parts list)

Note that one parts list covers all five exploded views. Although a single Item number may refer to the same part on all five exploded views, it is incorrect to assume that these parts are interchangeable. They are not. Therefore, it is imperative that items 1 through 3 above be provided when ordering your parts.

Failure to provide this information will only slow or prevent the processing of your order.

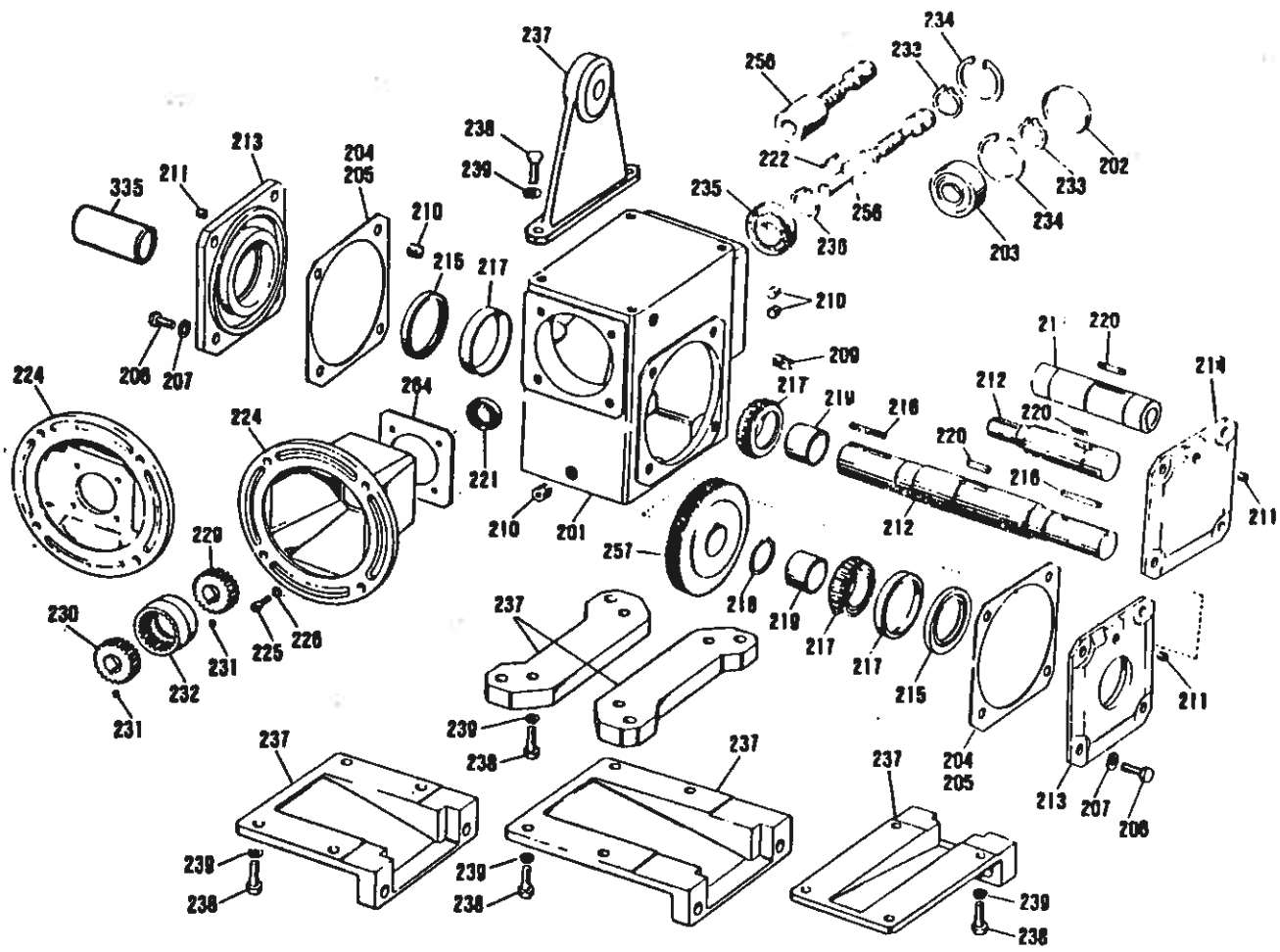

Single Reduction Unit 133, 175, 206 Series

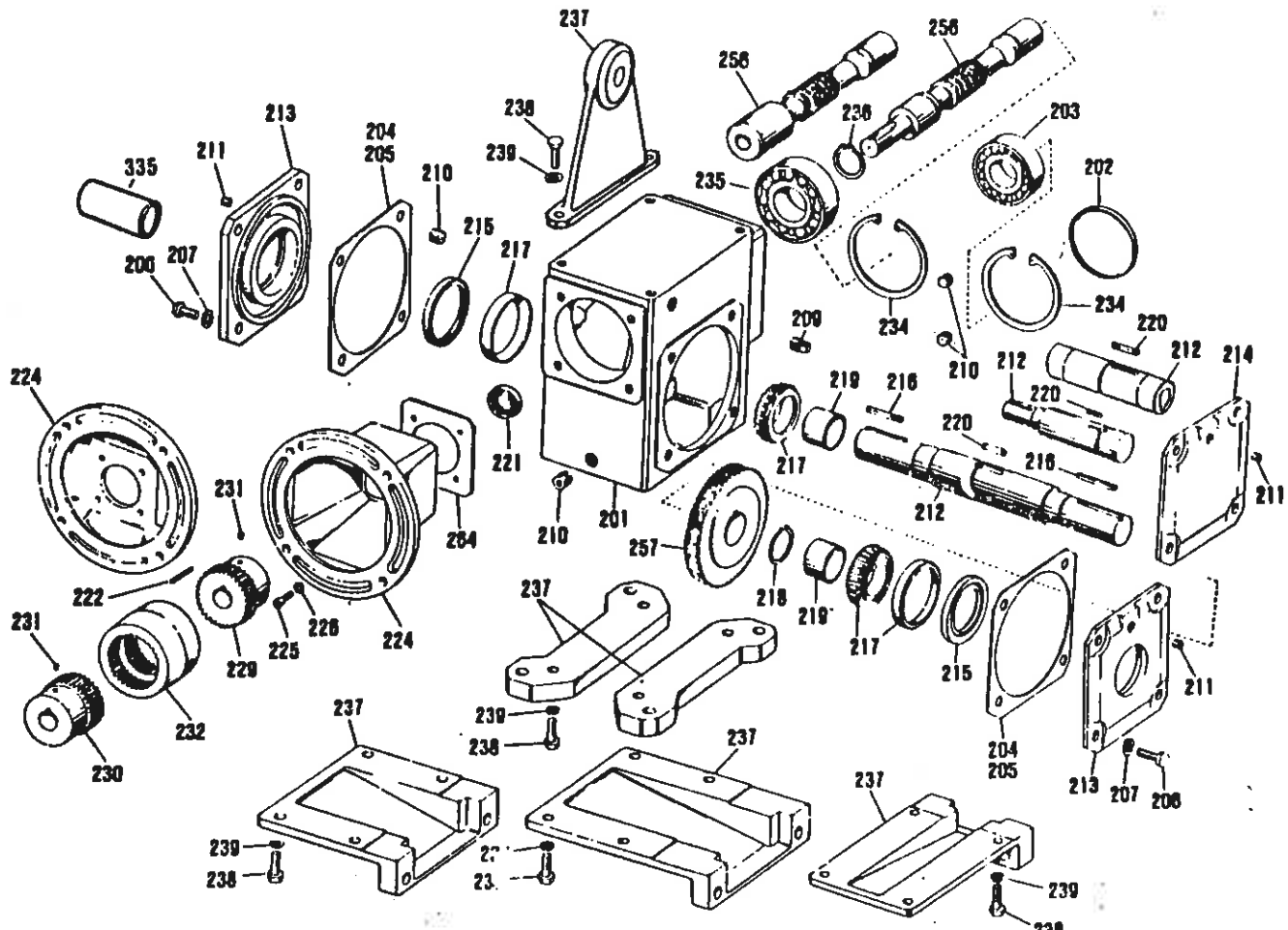

Single Reduction Unit 262, 325 Series

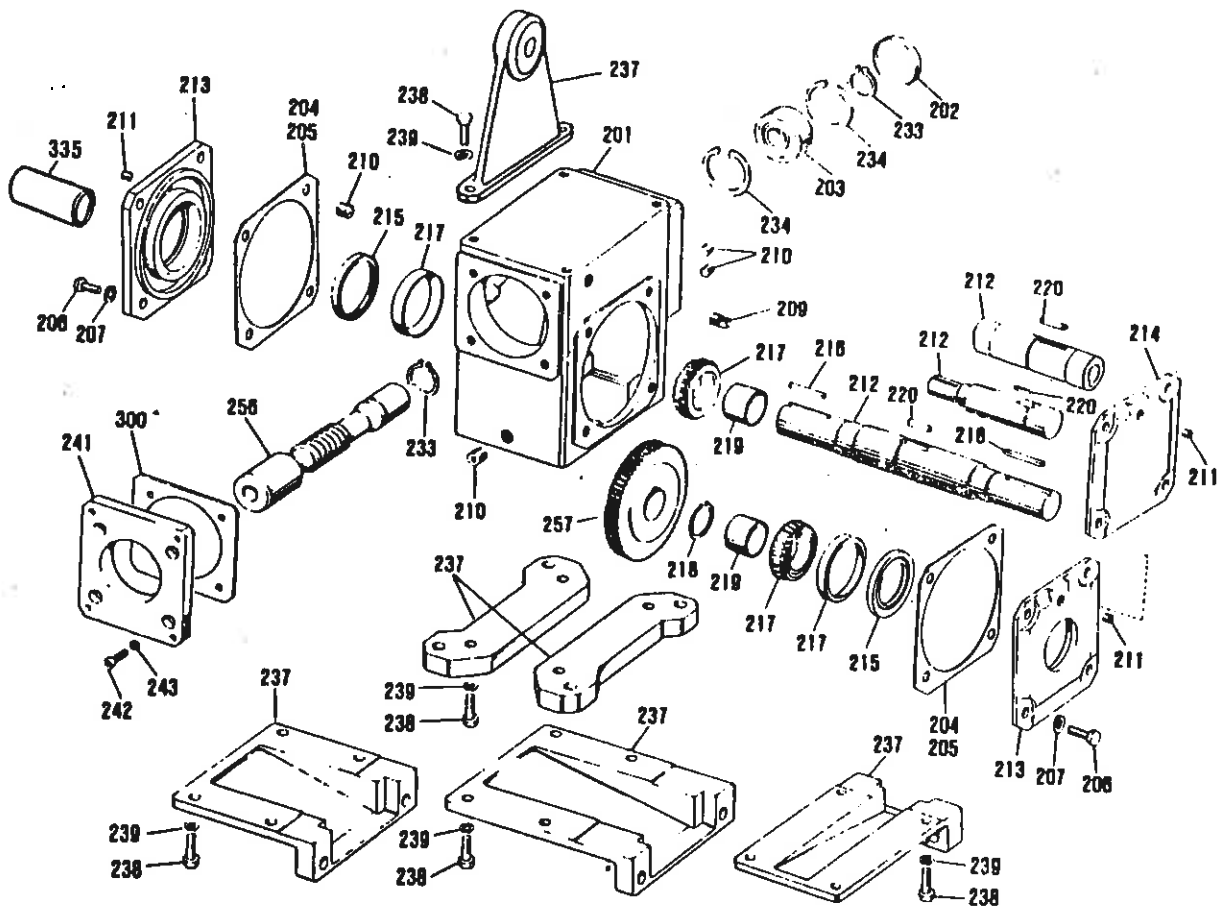

Double Reduction Secondary Unit 133, 175, 206 Series

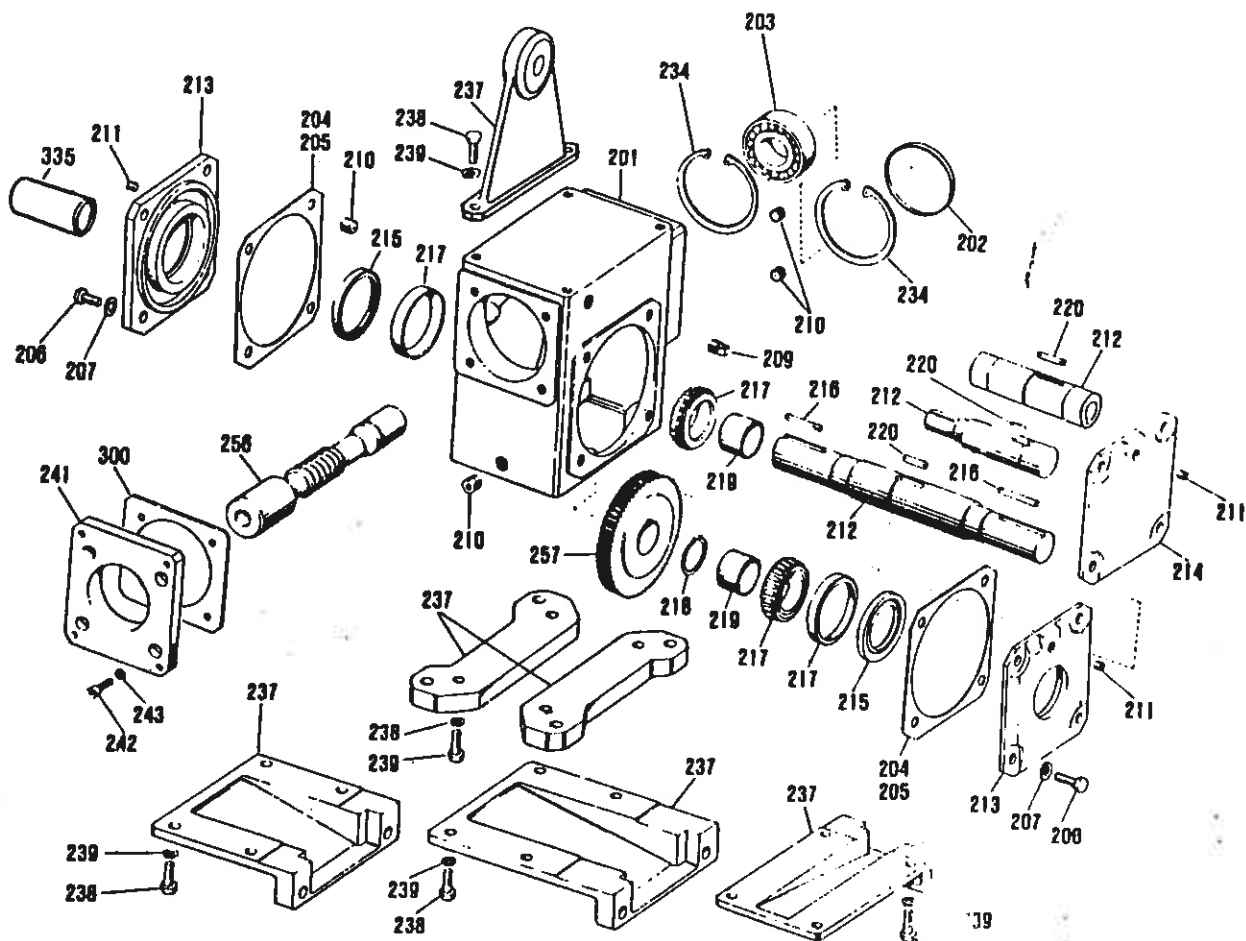

Double Reduction Secondary Unit 262, 325 Series

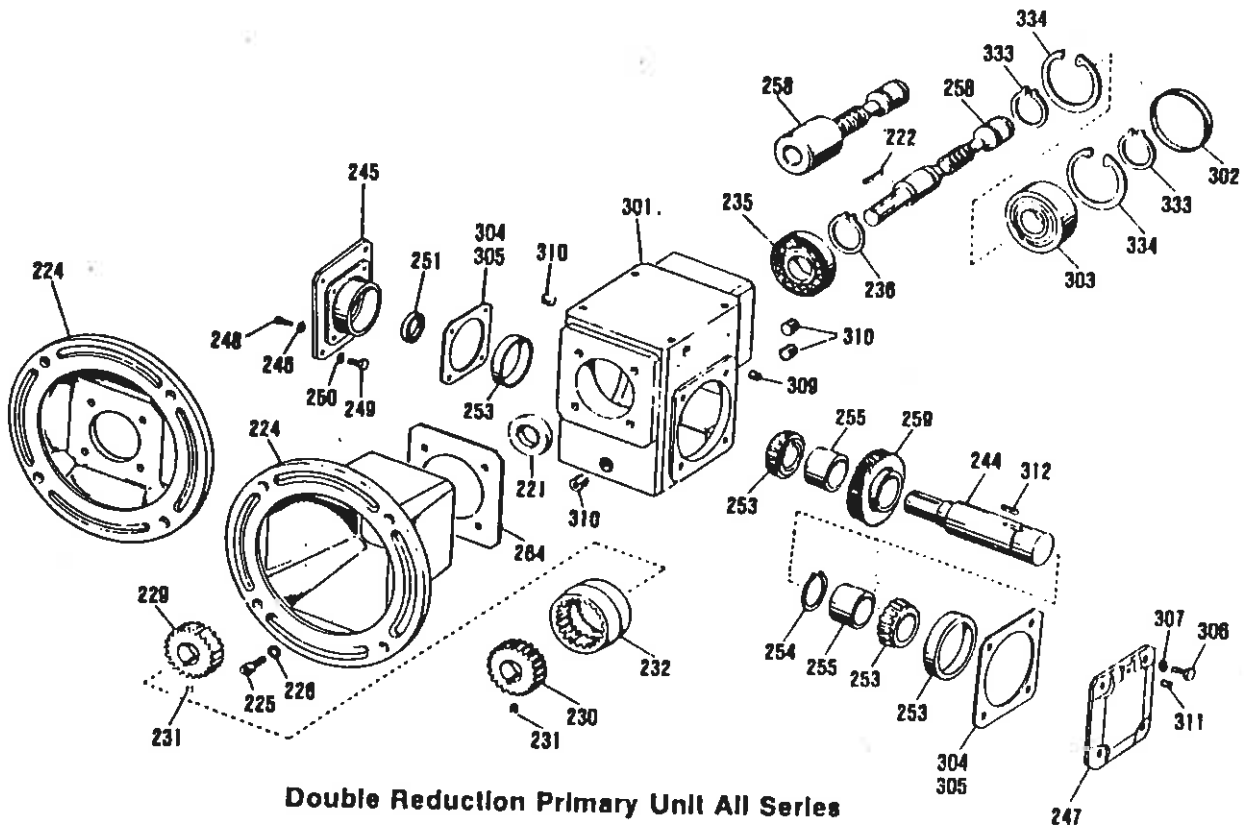

Double Reduction Primary Unit All Series

PARTS LIST
(Applies to all exploded views)

ITEM	DESCRIPTION	ITEM	DESCRIPTION	ITEM	DESCRIPTION
201	Housing	229	Coupling Hub (Unit)	255	Spacer
202	End Cover	230	Coupling Hub (Motor)	256	Worm
203	Bearing	231	Setscrew	257	Gear
204	Shim (.019 Thick)	232	Coupling Sleeve	258	Worm
205	Shim (.007 Thick)	233	Lock Ring	259	Gear
206	Capscrew	234	Lock Ring	260	Thrust Plate
207	Lock Washer	235	Bearing	261	Capscrew
209	Vent Plug	236	Lock Ring	264	Gasket
210	Pipe Plug	237	Base	300	Gasket
211	Pipe Plug	238	Capscrew	301	Housing
212	Output Shaft	239	Lock Washer	302	End Cover
213	Seal Cage	241	Secondary Adaptor	303	Bearing
214	End Cover	242	Capscrew	304	Shim (.019 Thick)
215	Oil Seal	243	Lock Washer	305	Shim (.007 Thick)
216	Key	244	Primary Output Shaft	306	Capscrew
217	Bearing	245	Primary Adaptor	307	Lock Washer
218	Lock Ring	246	Lock Washer	309	Vent Plug
219	Spacer	247	End Cover	310	Pipe Plug
220	Key	248	Capscrew	311	Pipe Plug
221	Oil Seal	249	Capscrew	312	Key
222	Key	250	Lock Washer	333	Lock Ring
224	Motor Flange	251	Oil Seal	334	Lock Ring
225	Capscrew	253	Bearing	335	Shaft Cover
226	Lock Washer	254	Lock Ring		

Note: When ordering replacement parts, specify model number, item number, and part description.

THERMOSWITCH®

Temperature Controllers

INSTALLATION INSTRUCTIONS

ATTENTION: TO ASSURE SAFE AND PROPER PERFORMANCE READ THESE INSTRUCTIONS.

GENERAL INFORMATION

The shell of each THERMOSWITCH unit contains the catalog number, the current rating, the temperature range and the contact arrangement.

The fifth digit of the catalog number describes whether contacts open or close on temperature rise. If contacts open on temperature rise (regular unit), the fifth digit of the catalog number is an even number such as 17000, 17002, etc. If contacts close on temperature rise (inverse unit), the fifth digit is an odd number such as 17021, 17023, etc.

UL Component recognized units will either have a "4" as the first digit (47002, etc.) or will bear the UL logo and utilize a 17000 series catalog number (17021, etc.).

If the fourth digit is other than "2" or "7" (such as 17021, 17071, etc.) it is compression operated. Inverse compression units are recommended if overshoots are to be encountered. Low temperature units can be overshoot to 500°F and high temperature units (-100 to 600°F) overshoot to 700°F for intervals not exceeding one hour.

INSTALLATION

Fenwal THERMOSWITCH® units are supplied in five basic head configurations - Cartridge, Block Head, Hex Head, Coupling Head and Circular Flange.

To avoid restricting shell expansion when making installations in solid metal blocks, a 5/8" diameter reamed hole for 5/8" units or a 13/16" diameter reamed hole for 13/16" diameter heavy duty units, is recommended. See specific controller style listing for additional installation instructions.

Cartridge [Style 1] (Includes moisture resistant high and low temperature units, A and C.) Hole should have short spline to receive the 1/8" diameter locating pin. This prevents the unit from rotating when the adjusting sleeve is turned. It may also be used for surface control if inserted into a Fenwal surface mounting block (Cat. No. 11100-2).

Block Head [Style 2] - is mounted in a similar manner to the cartridge type. If the unit is to be inserted into a reamed hole, two short pins should be mounted on either side of the hole. The pins should rest against the sides of the block head to prevent rotation of the unit.

Hex and Coupling Head [Styles 3 and 4] - can be installed like any pipe fitting. See Table 1 for maximum torque value.

Circular Flange [Style 5] - Three holes in flange allow for easy mounting on any flat surface.

NOTE: If the threaded units are installed in a pipe tee, the tee should be large enough to allow adequate circulation of the fluid around the temperature sensitive section of the unit.

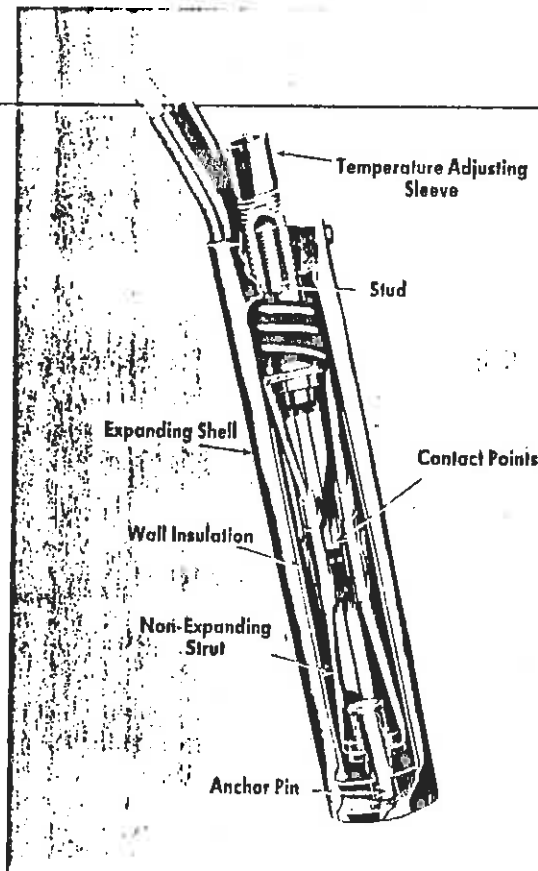

NOTE: Certain gases or liquids including water at elevated temperature could be corrosive and may also cause electrolytic action, which could severely shorten the life of the controller.

The rate of corrosion or electrolysis is influenced by a great many system parameters such as chemical makeup and temperature of the solution, stray electric currents, etc. Consult the supplier of your chemicals or the factory for suggestions.

TABLE I - Torque

Max. Torque	THERMOSWITCH® Controller Types
35 ft. lbs.	5/8" Dia. Standard with N.P.T. *
70 ft. lbs.	13/16 Dia. Heavy Duty with N.P.T. **

* 4 ft. lbs.	When Teflon tape lubricant is used.
**8 ft. lbs.	

WARNING: Excessive torque may change temperature settings.

CAUTIONS!

- DO** connect THERMOSWITCH controller leads in series with the load and power supply.
- DO** be certain that there is sufficient but not excessive room for the installed THERMOSWITCH unit to expand in diameter and length.
- DO** use stainless steel heliarc welded thermowells, (Series 11100, 11200) or various platings which may increase controller life where corrosion or electrolysis is suspect.
- DO** insulate head of the THERMOSWITCH unit where large external temperature variation may occur. This precaution is not necessary on the junction box type. (Series 17700, 17800).
- DO** prevent internal damage by mechanically presetting regular tension units (those with catalog number containing fourth digit other than 2 or 7) to approximate required elevated temperature before inserting into process. Preset by turning adjusting sleeve counterclockwise following the adjustment rate information shown on Table II, Page 2.

MOUNTING STYLES

Moisture Resistant Units

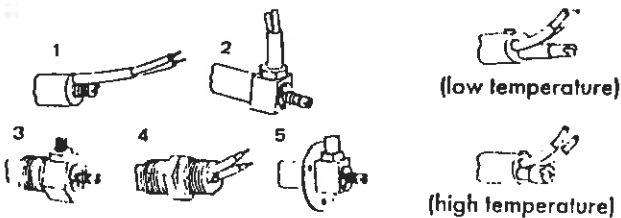

THERMOSWITCH®

Temperature Controllers

INSTALLATION INSTRUCTIONS

ATTENTION: TO ASSURE SAFE AND PROPER PERFORMANCE READ THESE INSTRUCTIONS.

GENERAL INFORMATION

The shell of each THERMOSWITCH unit contains the catalog number, the current rating, the temperature range and the contact arrangement.

The fifth digit of the catalog number describes whether contacts open or close on temperature rise. If contacts open on temperature rise (regular unit), the fifth digit of the catalog number is an even number such as 17000, 17002, etc. If contacts close on temperature rise (inverse unit), the fifth digit is an odd number such as 17021, 17023, etc.

UL Component recognized units will either have a "4" as the first digit (47002, etc.) or will bear the UL logo and utilize a 17000 series catalog number (17021, etc.).

If the fourth digit is other than "2" or "7" (such as 17021, 17071, etc.) it is compression operated. Inverse compression units are recommended if overshoots are to be encountered. Low temperature units can be overshoot to 500°F and high temperature units (-100 to 600°F) overshoot to 700°F for intervals not exceeding one hour.

INSTALLATION

Fenwal THERMOSWITCH® units are supplied in five basic head configurations - Cartridge, Block Head, Hex Head, Coupling Head and Circular Flange.

To avoid restricting shell expansion when making installations in solid metal blocks, a 5/8" diameter reamed hole for 5/8" units or a 13/16" diameter reamed hole for 13/16" diameter heavy duty units, is recommended. See specific controller style listing for additional installation instructions.

Cartridge [Style 1] (Includes moisture resistant high and low temperature units, A and C.) Hole should have short spline to receive the 1/8" diameter locating pin. This prevents the unit from rotating when the adjusting sleeve is turned. It may also be used for surface control if inserted into a Fenwal surface mounting block (Cat. No. 11100-2).

Block Head [Style 2] - is mounted in a similar manner to the cartridge type. If the unit is to be inserted into a reamed hole, two short pins should be mounted on either side of the hole. The pins should rest against the sides of the block head to prevent rotation of the unit.

Hex and Coupling Head [Styles 3 and 4] - can be installed like any pipe fitting. See Table 1 for maximum torque value.

Circular Flange [Style 5] - Three holes in flange allow for easy mounting on any flat surface.

NOTE: If the threaded units are installed in a pipe tee, the tee should be large enough to allow adequate circulation of the fluid around the temperature sensitive section of the unit.

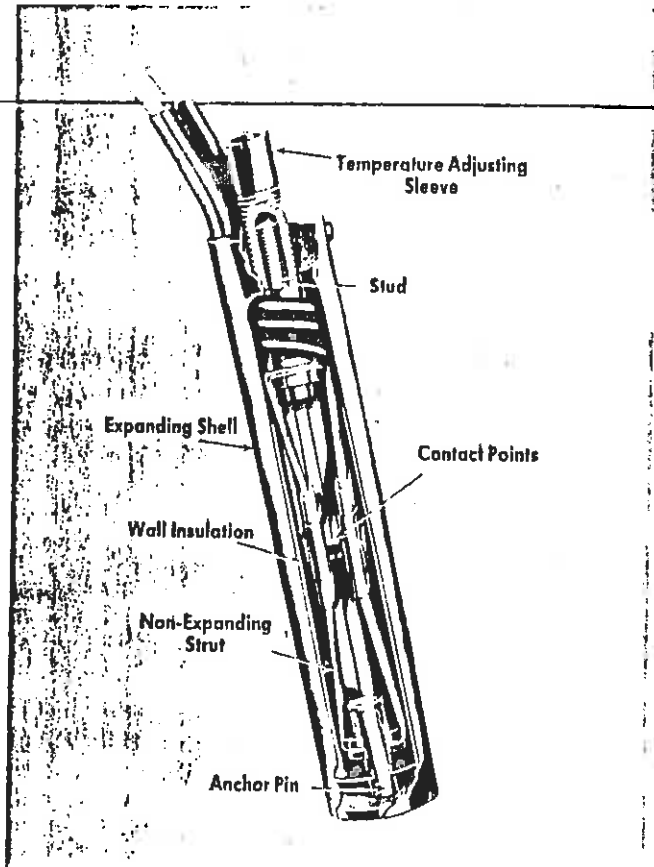

NOTE: Certain gases or liquids including water at elevated temperature could be corrosive and may also cause electrolytic action, which could severely shorten the life of the controller.

The rate of corrosion or electrolysis is influenced by a great many system parameters such as chemical makeup and temperature of the solution, stray electric currents, etc. Consult the supplier of your chemicals or the factory for suggestions.

TABLE 1 - Torque

Max. Torque	THERMOSWITCH® Controller Types
35 ft. lbs.	5/8" Dia. Standard with N.P.T. *
70 ft. lbs.	13/16 Dia. Heavy Duty with N.P.T. **

* 4 ft. lbs.	When Teflon tape lubricant is used.
**8 ft. lbs.	

WARNING: Excessive torque may change temperature settings.

CAUTIONS!

- DO connect THERMOSWITCH controller leads in series with the load and power supply.
- DO be certain that there is sufficient but not excessive room for the installed THERMOSWITCH unit to expand in diameter and length.
- DO use stainless steel heliarc welded thermowells, (Series 11100, 11200) or various platings which may increase controller life where corrosion or electrolysis is suspect.
- DO insulate head of the THERMOSWITCH unit where large external temperature variation may occur. This precaution is not necessary on the junction box type. (Series 17700, 17800).
- DO prevent internal damage by mechanically presetting regular tension units (those with catalog number containing fourth digit other than 2 or 7) to approximate required elevated temperature before inserting into process. Preset by turning adjusting sleeve counterclockwise following the adjustment rate information shown on Table II, Page 2.

MOUNTING STYLES

Moisture Resistant Units

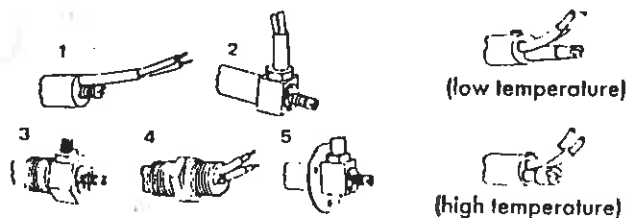

THERMOSWITCH®

Temperature Controllers

INSTALLATION INSTRUCTIONS

ATTENTION: TO ASSURE SAFE AND PROPER PERFORMANCE READ THESE INSTRUCTIONS.

GENERAL INFORMATION

The shell of each THERMOSWITCH unit contains the catalog number, the current rating, the temperature range and the contact arrangement.

The fifth digit of the catalog number describes whether contacts open or close on temperature rise. If contacts open on temperature rise (regular unit), the fifth digit of the catalog number is an even number such as 17000, 17002, etc. If contacts close on temperature rise (inverse unit), the fifth digit is an odd number such as 17021, 17023, etc.

UL Component recognized units will either have a "4" as the first digit (47002, etc.) or will bear the UL logo and utilize a 17000 series catalog number (17021, etc.).

If the fourth digit is other than "2" or "7" (such as 17021, 17071, etc.) it is compression operated. Inverse compression units are recommended if overshoots are to be encountered. Low temperature units can be overshoot to 500°F and high temperature units (-100 to 600°F) overshoot to 700°F for intervals not exceeding one hour.

INSTALLATION

Fenwal THERMOSWITCH® units are supplied in five basic head configurations - Cartridge, Block Head, Hex Head, Coupling Head and Circular Flange.

To avoid restricting shell expansion when making installations in solid metal blocks, a 5/8" diameter reamed hole for 5/8" units or a 13/16" diameter reamed hole for 13/16" diameter heavy duty units, is recommended. See specific controller style listing for additional installation instructions.

Cartridge [Style 1] (Includes moisture resistant high and low temperature units, A and C.) Hole should have short spline to receive the 1/8" diameter locating pin. This prevents the unit from rotating when the adjusting sleeve is turned. It may also be used for surface control if inserted into a Fenwal surface mounting block (Cat. No. 11100-2).

Block Head [Style 2] - is mounted in a similar manner to the cartridge type. If the unit is to be inserted into a reamed hole, two short pins should be mounted on either side of the hole. The pins should rest against the sides of the block head to prevent rotation of the unit.

Hex and Coupling Head [Styles 3 and 4] - can be installed like any pipe fitting. See Table 1 for maximum torque value.

Circular Flange [Style 5] - Three holes in flange allow for easy mounting on any flat surface.

NOTE: If the threaded units are installed in a pipe tee, the tee should be large enough to allow adequate circulation of the fluid around the temperature sensitive section of the unit.

MOUNTING STYLES

Moisture Resistant Units

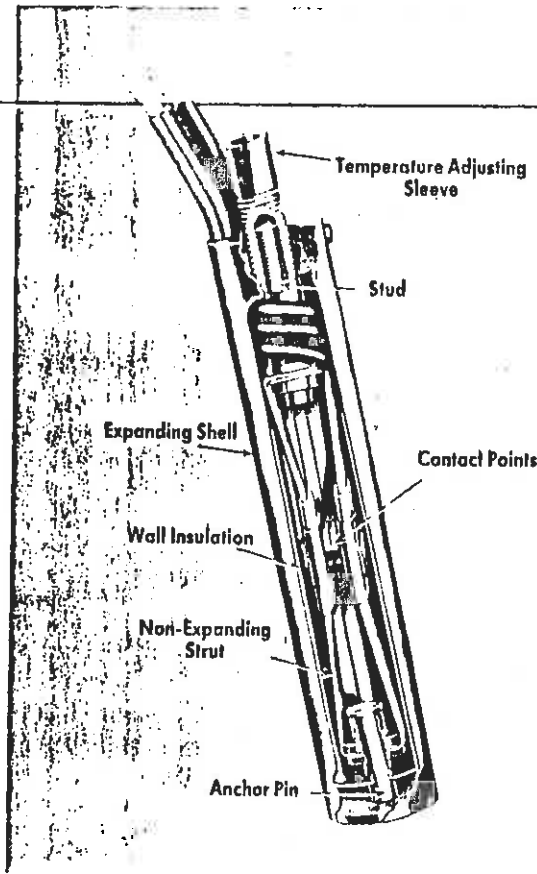
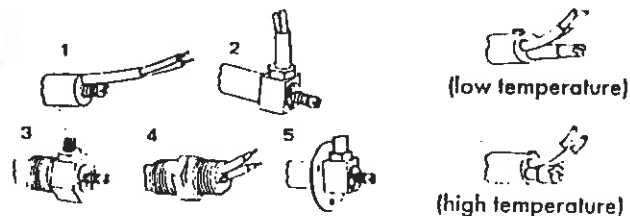

NOTE: Certain gases or liquids including water at elevated temperature could be corrosive and may also cause electrolytic action, which could severely shorten the life of the controller.

The rate of corrosion or electrolysis is influenced by a great many system parameters such as chemical makeup and temperature of the solution, stray electric currents, etc. Consult the supplier of your chemicals or the factory for suggestions.

TABLE I - Torque

Max. Torque	THERMOSWITCH® Controller Types
35 ft. lbs.	5/8" Dia. Standard with N.P.T. *
70 ft. lbs.	13/16 Dia. Heavy Duty with N.P.T. **

* 4 ft. lbs.	When Teflon tape lubricant is used.
**8 ft. lbs.	

WARNING: Excessive torque may change temperature settings.

CAUTIONS!

- DO connect THERMOSWITCH controller leads in series with the load and power supply.
- DO be certain that there is sufficient but not excessive room for the installed THERMOSWITCH unit to expand in diameter and length.
- DO use stainless steel heliarc welded thermowells, (Series 11100, 11200) or various platings which, may increase controller life where corrosion or electrolysis is suspect.
- DO insulate head of the THERMOSWITCH unit where large external temperature variation may occur. This precaution is not necessary on the junction box type. (Series 17700, 17800).
- DO prevent internal damage by mechanically presetting regular tension units (those with catalog number containing fourth digit other than 2 or 7) to approximate required elevated temperature before inserting into process. Preset by turning adjusting sleeve counterclockwise following the adjustment rate information shown on Table II, Page 2.

AUTIONS (Continued)

- DON'T** immerse your unit in liquids or vapors unless it was specified for that job.
- DON'T** seal head with silicone materials.
- DON'T** exceed the ratings indicated on THERMOSWITCH unit shell.
- DON'T** thermally shield unit from medium being controlled.
- DON'T** remove adjusting screw or turn adjusting screw in farther than necessary for desired operation. This action may permanently damage the unit and may void standard Fenwal warranty!
- DON'T** oil your unit. Oil around adjusting screw will flow inside, contaminating contacts.
- DON'T** allow moisture buildup in head cavity area of 37X0X0-000 Moisture Resistant Units. Where excessive moisture is a problem, specify Special Feature 01-982039-00X when ordering.
- DON'T** try to repair unit yourself.
- DON'T** handle unit with pliers or force it into position either by hand or tools, or apply excessive torque in tightening threaded units.
- DON'T** subject shell of unit to deformation.
- DON'T** over-torque threaded units.

TESTING AND ADJUSTMENT



The arrow on the head of THERMOSWITCH unit indicates direction to turn adjusting screw to increase temperature setting. Torque in excess of 15 inch pounds on adjusting sleeve will deform slot.

Each full turn of adjusting sleeve will change temperature the approximate number of degrees as follows:

TABLE II – Adjustment Rates for Thermoswitch Units

TENSION OPERATED		COMPRESSION OPERATED	
Catalog Series Number	Approx. F° per full turn of adj. sleeve	Catalog Series Number	Approx. F° per full turn of adj. sleeve
15050 to 16051	165	13121-1	1000
17000 to 17503	90-115	17020 to 17523	90-100
17700 to 17701	145	17720 to 17721	85
17702 to 17703	180	17722 to 17723	100-150
17800 to 17801	125	17820 to 17821	75
17802 to 17803	160	17822 to 17823	115
18000 to 18003	80-100	18020 to 18023	70-135
01-37X0X0-000	90		

After the THERMOSWITCH unit has been installed, final adjustment can be made by allowing the unit to operate for several cycles to permit the controlled system to stabilize and then adjust to desired temperatures. The system should then be cooled to ambient temperature, reheated and stabilized to check the setting.

To adjust a high temperature moisture resistant THERMOSWITCH unit (Cat. No. 01-370020-000) it is necessary to remove the seal cap. A screwdriver adjustment is then made internally. Use caution when making adjustments at temperature extremes.

Where extremely accurate temperature control is desired several readjustments may be necessary to stabilize the THERMOSWITCH control after which the adjustment will be maintained.

CONTACT PROTECTION

Capacitors are not required under average conditions. For smoother control at small loads, on D.C. applications or to prevent contact bounce due to vibration, the following table is recommended as a guide:

TABLE III – Contact Protection

VOLTAGE	SERVICE	CAPACITANCE MFD (non-polarized)
120VAC	Resistance	Non required
240VAC	Resistance	.1
120 or 240VAC or DC	Relays, Magnetic Contactors	.001 to .01
15–25VAC or DC	Relays	.02
120 or 240VAC	Motor	Use Relay

NOTE: Capacitors should be wired in parallel with thermostat lead connections. Capacitors should be rated for a minimum of 600VDC with 120VAC circuits and a minimum of 1000VDC for 240VAC circuits.

TESTING TEMPERATURE SET POINT

The *Set Point Temperature* is the temperature at which the contacts on a THERMOSWITCH unit just "make" (close). All THERMOSWITCH units are set at room temperature (75°F ± 15°F) unless otherwise specified in which case they are factory preset at any specified temperature within listed temperature range and selling tolerance of THERMOSWITCH unit.

If customer requires testing of temperature set point, it is recommended that testing devices can be used similar to those at the factory. An ideal thermal installation may require that the THERMOSWITCH unit be located as near as possible to the heat source. Testing the temperature set point of a THERMOSWITCH unit in an application or under conditions where heat source is remotely located from THERMOSWITCH unit, or when ambient temperature conditions are far below or above 75°F, may give misleading results. In some cases, this has led to rejection of units which were actually within proper selling tolerance. Therefore we recommend the use of a Fenwal Model 80001-0 Test Kit, for testing temperature set points on Fenwal THERMOSWITCH units.

For customers who wish to build their own test equipment we recommend that you contact your nearest Fenwal Representative. He is equipped to give you further guidance in setting up a good thermal test system.

LIMITED WARRANTY STATEMENT

Fenwal Incorporated represents that this product is free from defects in material and workmanship, and it will repair or replace any product or part thereof which proves to be defective in workmanship or material for a period of twelve (12) months from the date of purchase but not to exceed eighteen (18) months after shipment by the seller. For a full description of Fenwal's LIMITED WARRANTY, which among other things, limits the duration of warranties of MERCHANTABILITY and FITNESS FOR A PARTICULAR PURPOSE and EXCLUDES liability for CONSEQUENTIAL DAMAGES, please read the entire LIMITED WARRANTY on the Fenwal Quotation, Acceptance of Order and/or Original Invoice which will become a part of your sales agreement. Defective units should be returned to the factory, Ashland, Massachusetts, shipment prepaid. Fenwal Incorporated will repair or replace and ship prepaid.

FENWAL INCORPORATED

Division of Kidde, Inc.

KIDDE

400 Main Street Ashland, Massachusetts 01720 (617) 881-2000

1.10 S 100M 11/86 Printed in U.S.A.

CAUTIONS (Continued)

- DON'T** immerse your unit in liquids or vapors unless it was specified for that job.
- DON'T** seal head with silicone materials.
- DON'T** exceed the ratings indicated on THERMOSWITCH unit shell.
- DON'T** thermally shield unit from medium being controlled.
- DON'T** remove adjusting screw or turn adjusting screw in farther than necessary for desired operation. This action may permanently damage the unit and may void standard Fenwal warranty!
- DON'T** oil your unit. Oil around adjusting screw will flow inside, contaminating contacts.
- DON'T** allow moisture buildup in head cavity area of 37X0X0-000 Moisture Resistant Units. Where excessive moisture is a problem, specify Special Feature 01-982039-00X when ordering.
- DON'T** try to repair unit yourself.
- DON'T** handle unit with pliers or force it into position either by hand or tools, or apply excessive torque in tightening threaded units.
- DON'T** subject shell of unit to deformation.
- DON'T** over-torque threaded units.

TESTING AND ADJUSTMENT



The arrow on the head of THERMOSWITCH unit indicates direction to turn adjusting screw to increase temperature setting. Torque in excess of 15 inch pounds on adjusting sleeve will deform slot.

Each full turn of adjusting sleeve will change temperature the approximate number of degrees as follows:

TABLE II – Adjustment Rates for Thermoswitch Units

TENSION OPERATED		COMPRESSION OPERATED	
Catalog Series Number	Approx. F° per full turn of adj. sleeve	Catalog Series Number	Approx. F° per full turn of adj. sleeve
15050 to 16051	165	13121-1	1000
17000 to 17503	90-115	17020 to 17523	90-100
17700 to 17701	145	17720 to 17721	85
17702 to 17703	180	17722 to 17723	100-150
17800 to 17801	125	17820 to 17821	75
17802 to 17803	160	17822 to 17823	115
18000 to 18003	80-100	18020 to 18023	70-135
01-37X0X0-000	90-		

After the THERMOSWITCH unit has been installed, final adjustment can be made by allowing the unit to operate for several cycles to permit the controlled system to stabilize and then adjust to desired temperatures. The system should then be cooled to ambient temperature, reheated and stabilized to check the setting.

To adjust a high temperature moisture resistant THERMOSWITCH unit (Cat. No. 01-370020-000) it is necessary to remove the seal cap. A screwdriver adjustment is then made internally. Use caution when making adjustments at temperature extremes.

Where extremely accurate temperature control is desired several readjustments may be necessary to stabilize the THERMOSWITCH control after which the adjustment will be maintained.

CONTACT PROTECTION

Capacitors are not required under average conditions. For smoother control at small loads, on D.C. applications or to prevent contact bounce due to vibration, the following table is recommended as a guide:

TABLE III – Contact Protection

VOLTAGE	SERVICE	CAPACITANCE MFD (non-polarized)
120VAC	Resistance	Non required
240VAC	Resistance	.1
120 or 240VAC or DC	Relays, Magnetic Contactors	.001 to .01
15-25VAC or DC	Relays	.02
120 or 240VAC	Motor	Use Relay

NOTE: Capacitors should be wired in parallel with thermostat lead connections. Capacitors should be rated for a minimum of 600VDC with 120VAC circuits and a minimum of 1000VDC for 240VAC circuits.

TESTING TEMPERATURE SET POINT

The Set Point Temperature is the temperature at which the contacts on a THERMOSWITCH unit just "make" (close). All THERMOSWITCH units are set at room temperature (75°F ± 15°F) unless otherwise specified in which case they are factory preset at any specified temperature within listed temperature range and setting tolerance of THERMOSWITCH unit.

If customer requires testing of temperature set point, it is recommended that testing devices can be used similar to those of the factory. An ideal thermal installation may require that the THERMOSWITCH unit be located as near as possible to the heat source. Testing the temperature set point of a THERMOSWITCH unit in an application or under conditions where heat source is remotely located from THERMOSWITCH unit, or when ambient temperature conditions are far below or above 75°F, may give misleading results. In some cases, this has led to rejection of units which were actually within proper setting tolerance. Therefore we recommend the use of a Fenwal Model 80001-0 Test Kit, for testing temperature set points on Fenwal THERMOSWITCH units.

For customers who wish to build their own test equipment we recommend that you contact your nearest Fenwal Representative. He is equipped to give you further guidance in setting up a good thermal test system.

LIMITED WARRANTY STATEMENT

Fenwal Incorporated represents that this product is free from defects in material and workmanship, and it will repair or replace any product or part thereof which proves to be defective in workmanship or material for a period of twelve (12) months from the date of purchase but not to exceed eighteen (18) months after shipment by the seller. For a full description of Fenwal's LIMITED WARRANTY, which among other things, limits the duration of warranties of MERCHANTABILITY and FITNESS FOR A PARTICULAR PURPOSE and EXCLUDES liability for CONSEQUENTIAL DAMAGES, please read the entire LIMITED WARRANTY on the Fenwal Quotation, Acceptance of Order and/or Original Invoice which will become a part of your sales agreement. Defective units should be returned to the factory, Ashland, Massachusetts, shipment prepaid. Fenwal Incorporated will repair or replace and ship prepaid.

FENWAL INCORPORATED

Division of Kidde, Inc.

KIDDE

400 Main Street Ashland, Massachusetts 01720 (617) 881-2000

1.10S 100M 11/86 Printed in U.S.A.

CAUTIONS (Continued)

- DON'T** immerse your unit in liquids or vapors unless it was specified for that job.
- DON'T** seal head with silicone materials.
- DON'T** exceed the ratings indicated on THERMOSWITCH unit shell.
- DON'T** thermally shield unit from medium being controlled.
- DON'T** remove adjusting screw or turn adjusting screw in farther than necessary for desired operation. This action may permanently damage the unit and may void standard Fenwal warranty!
- DON'T** oil your unit. Oil around adjusting screw will flow inside, contaminating contacts.
- DON'T** allow moisture buildup in head cavity area of 37X0X0-000 Moisture Resistant Units. Where excessive moisture is a problem, specify Special Feature 01-982039-00X when ordering.
- DON'T** try to repair unit yourself.
- DON'T** handle unit with pliers or force it into position either by hand or tools, or apply excessive torque in tightening threaded units.
- DON'T** subject shell of unit to deformation.
- DON'T** over-torque threaded units.

TESTING AND ADJUSTMENT



The arrow on the head of THERMOSWITCH unit indicates direction to turn adjusting screw to increase temperature setting. Torque in excess of 15 inch pounds on adjusting sleeve will deform slot.

Each full turn of adjusting sleeve will change temperature the approximate number of degrees as follows:

TABLE II - Adjustment Rates for Thermoswitch Units

TENSION OPERATED		COMPRESSION OPERATED	
Catalog Series Number	Approx. F° per full turn of adj. sleeve	Catalog Series Number	Approx. F° per full turn of adj. sleeve
15050 to 16051	165	13121-1	1000
17000 to 17503	90-115	17020 to 17523	90-100
17700 to 17701	145	17720 to 17721	85
17702 to 17703	180	17722 to 17723	100-150
17800 to 17801	125	17820 to 17821	75
17802 to 17803	160	17822 to 17823	115
18000 to 18003	80-100	18020 to 18023	70-135
01-37X0X0-000	90		

After the THERMOSWITCH unit has been installed, final adjustment can be made by allowing the unit to operate for several cycles to permit the controlled system to stabilize and then adjust to desired temperatures. The system should then be cooled to ambient temperature, reheated and stabilized to check the setting.

To adjust a high temperature moisture resistant THERMOSWITCH unit (Cat. No. 01-370020-000) it is necessary to remove the seal cap. A screwdriver adjustment is then made internally. Use caution when making adjustments at temperature extremes.

Where extremely accurate temperature control is desired several readjustments may be necessary to stabilize the THERMOSWITCH control after which the adjustment will be maintained.

CONTACT PROTECTION

Capacitors are not required under average conditions. For smoother control at small loads, on D.C. applications or to prevent contact bounce due to vibration, the following table is recommended as a guide:

TABLE III - Contact Protection

VOLTAGE	SERVICE	CAPACITANCE MFD (non-polarized)
120VAC	Resistance	Non required
240VAC	Resistance	.1
120 or 240VAC or DC	Relays, Magnetic Contactors	.001 to .01
15-25VAC or DC	Relays	.02
120 or 240VAC	Motor	Use Relay

NOTE: Capacitors should be wired in parallel with thermostat load connections. Capacitors should be rated for a minimum of 600VDC with 120VAC circuits and a minimum of 1000VDC for 240VAC circuits.

TESTING TEMPERATURE SET POINT

The *Set Point Temperature* is the temperature at which the contacts on a THERMOSWITCH unit just "make" (close). All THERMOSWITCH units are set at room temperature (75°F ± 15°F) unless otherwise specified in which case they are factory preset at any specified temperature within listed temperature range and setting tolerance of THERMOSWITCH unit.

If customer requires testing of temperature set point, it is recommended that testing devices can be used similar to those at the factory. An ideal thermal installation may require that the THERMOSWITCH unit be located as near as possible to the heat source. Testing the temperature set point of a THERMOSWITCH unit in an application or under conditions where heat source is remotely located from THERMOSWITCH unit, or when ambient temperature conditions are far below or above 75°F, may give misleading results. In some cases, this has led to rejection of units which were actually within proper setting tolerance. Therefore we recommend the use of a Fenwal Model 80001-0 Test Kit, for testing temperature set points on Fenwal THERMOSWITCH units.

For customers who wish to build their own test equipment we recommend that you contact your nearest Fenwal Representative. He is equipped to give you further guidance in setting up a good thermal test system.

LIMITED WARRANTY STATEMENT

Fenwal Incorporated represents that this product is free from defects in material and workmanship, and it will repair or replace any product or part thereof which proves to be defective in workmanship or material for a period of twelve (12) months from the date of purchase but not to exceed eighteen (18) months after shipment by the seller. For a full description of Fenwal's LIMITED WARRANTY, which among other things, limits the duration of warranties of MERCHANTABILITY and FITNESS FOR A PARTICULAR PURPOSE and EXCLUDES liability for CONSEQUENTIAL DAMAGES, please read the entire LIMITED WARRANTY on the Fenwal Quotation, Acceptance of Order and/or Original Invoice which will become a part of your sales agreement. Defective units should be returned to the factory, Ashland, Massachusetts, shipment prepaid. Fenwal Incorporated will repair or replace and ship prepaid.