

B Y T E X

FILM SUPPLYING SYSTEM

MODEL BY-10A

INSTRUCTION MANUAL



YAMAKAWA ENGINEERING

# TO OUR CUSTOMERS:

Thank you for purchasing "BYTEX" (Film Supplying Module). This Instruction Manual has been provided to help you fully understand the correct operation of this wrapping film supplying system. Please read this Instruction Manual carefully to ensure the safe, efficient, and economical operation of "BYTEX". Before beginning operation, please pay special attention to the following points:

- \* Make sure that the routine checks, maintenance and lubrication are performed regularly and correctly.
- \* Be sure to use the lubricants specified in this manual.
- \* It had better to use the specified film roll with BYTEX.
- \* Make sure that pre-inputed Data in Inverter is correct or suitable for your arrangement. please refer 10 page.

# Contents

## Chapter 1: General

1-1	Names of Parts and Dimensions	1
1-2	Outline	2
1-3	Specifications	3
1-4	Fitting procedure of BYTEX	4

## Chapter 2: Operations

2-1	Preparation and Starting Check	5
2-2	Film Loading Procedure	6
2-3	Release Procedure from Film Block	7

## Chapter 3: Maintenance

3-1	Maintenance List	8
3-2	Oils and Lubrication Schedule	8

## Chapter 4: Electric Connection

4-1	BYTEX BY-10A Wiring	9
4-2	Inverter (Data Check Sheet)	10

## Chapter 5: Parts List

D1 ~ D6

# Chapter 1: General

## 1-1 Names of Parts ,and Dimensions (mm)

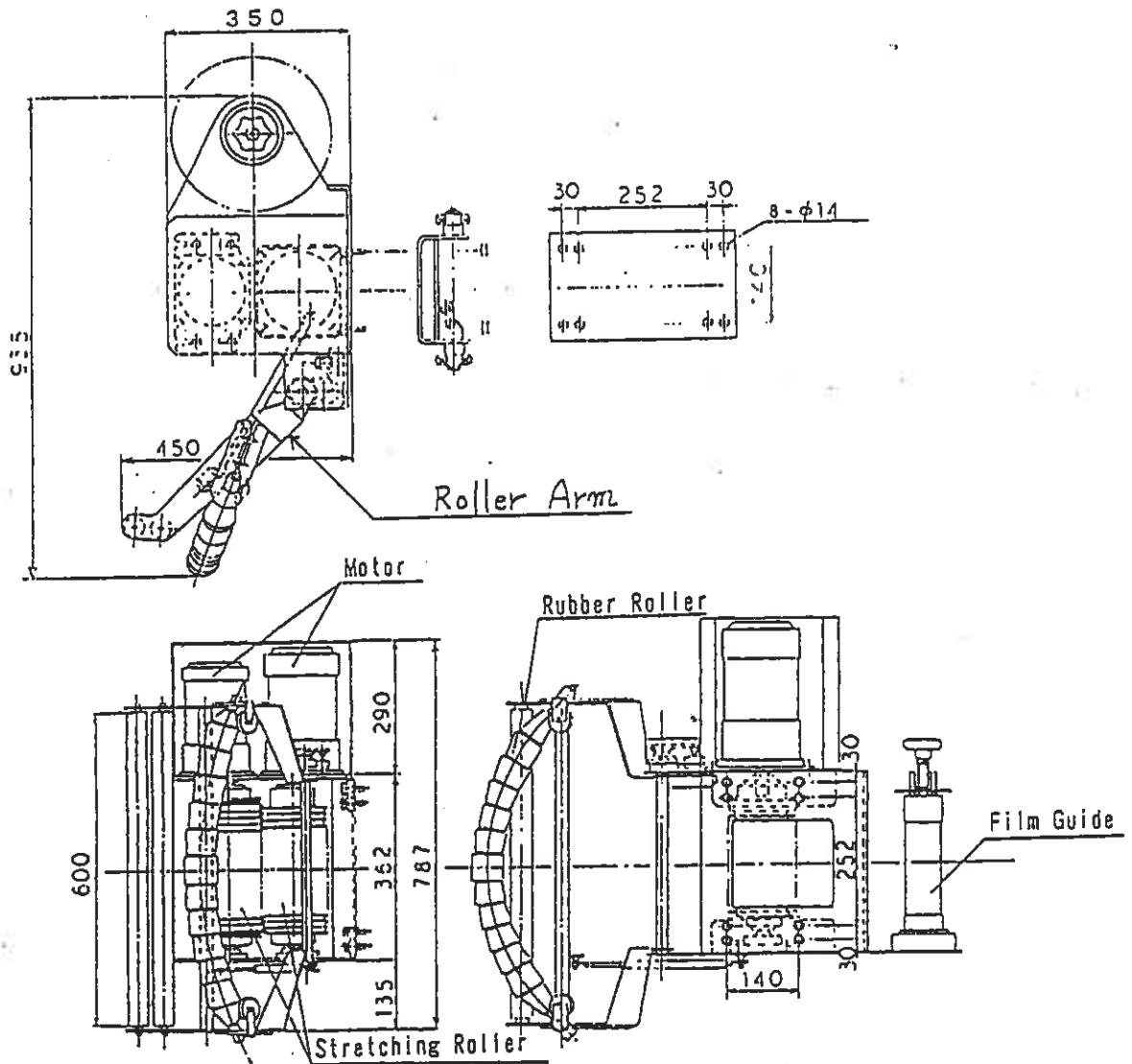

1-2 OUTLINE

This module (BYTEX BY-10A) can make the wrapping film stretched & widen simultaneously to longitudinally & transversely directions with combination of two corrugated design rollers.

- \* Stretching ratio (film width) is alternative by adjustment of clearance between rollers.
- \* Film tension is also adjustable by equipping with frequency setter (optional parts).
- \* In order to film set through rollers safely, please set up your electric sequential connection as follows.
  - ◆ At manual mode: Make output from inverter "ON" to be motor for roller functioned.
  - ◆ At automatic mode: Make output "OFF" as to stop the turn table and rollers synchronously.
- \* Film roll is available with both side (the film surface is adhesive or not is not a question). Refer 6 Page.

► Move No.1 roller to change the clearance, then you can change the width of stretched film.

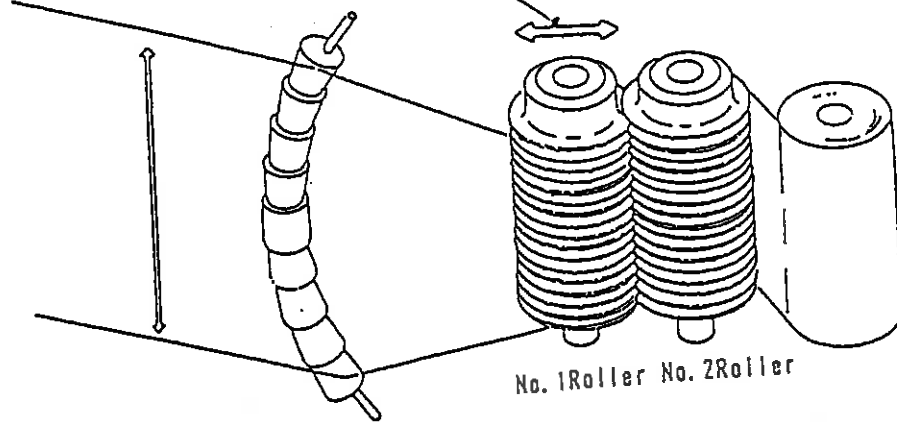

Specifications	BY-10A
Film Elevation Speed	60m/min (STD)
Film Width	250mm (10") (~ 270mm)
Film Roll Diameter	Max. 300mm
Film Thickness	Max. 35 $\mu$
Film Extension (Width)	Max: 560 mm (20")
Stretching Method	Simultaneous 2way Stretching
Stretching Ratio (Vertical)	$\times 2.5$
Stretching Ratio (Horizontal)	$\times 2$ (1.1~2.2)
Enlargement Ratio	$\times 5$ AREA
Facility Power 50, 60 H z	AC 210 $\pm$ 20V (3-phase or 1-phase)
» (U P - Transformer )	AC 110 $\pm$ 10V (1-phase)
Equipment Weight	80kg

1-4 FITTING PROCEDURE OF BYTEX  
 (Fit Film Supplying Module to Your Machine)

- ◆ Use eight bolts of M12/P-1.75 attached on the Back Panel to join this module.
- ◆ In case of welding fit, set the brackets with bolts and then weld brackets to your carriage mast.
- ◆ Power Unit (Inverter) and transformer should be set into your machine. Refer page 9 as for the electric connection diagram.

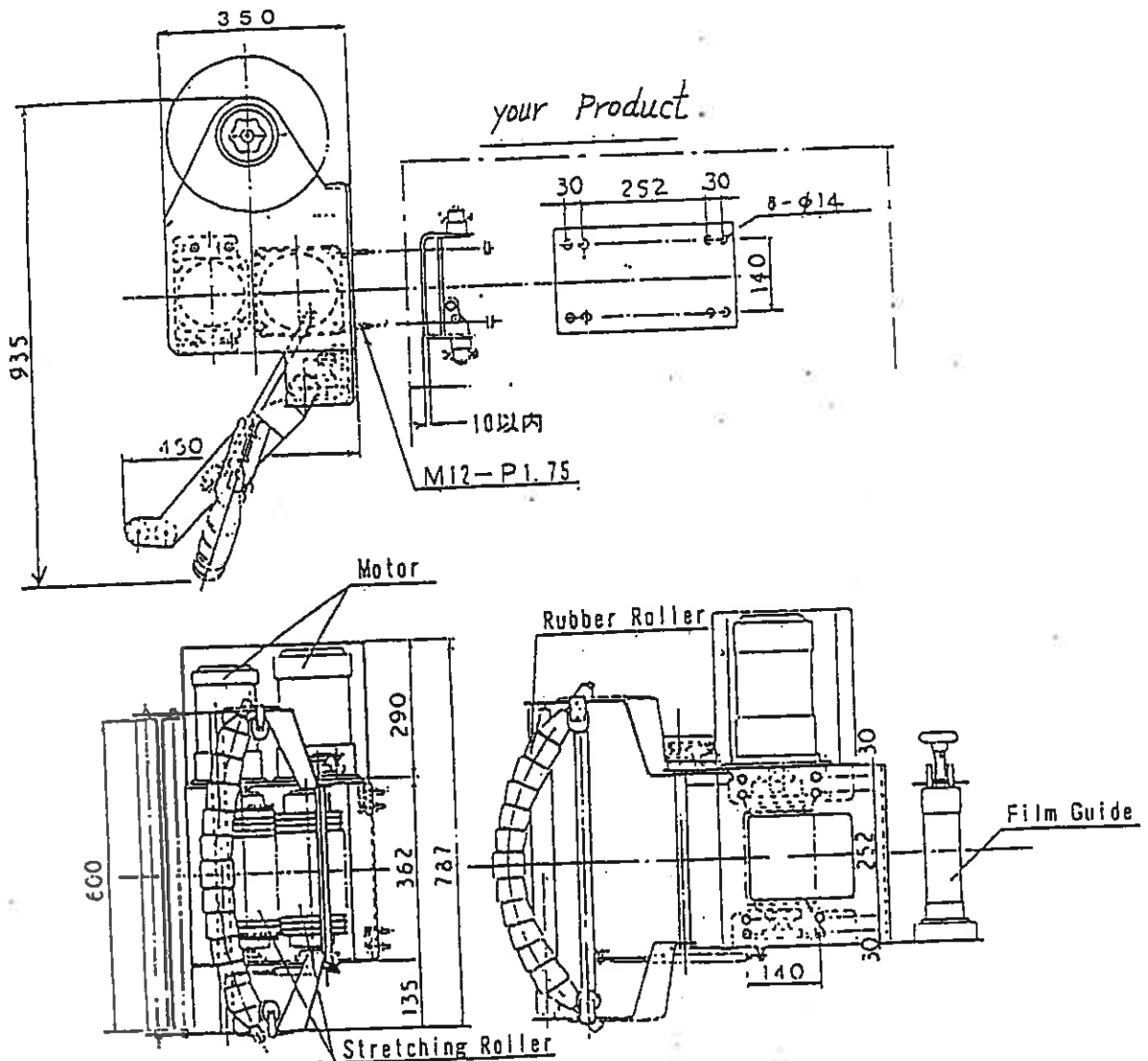

## Chapter 2 :OPERATIONS

### 2-1 Preparation and Starting Check

Check the connections from the power supply to the system.  
Check to see the follows before switch ON.

- 1) Any faults or malfunction on corrugated rollers.  
(VISUALLY)
- 2) Check the smoothness of rotation and suspension of  
corrugated rollers by shifting the roller arm.  
(MANUAL)
- 3) Check the wrapping film is set rightly.refer page 6.  
(VISUALLY)
- 4) Check film roll is set properly with surface or  
reverse.(as you needed)  
Make sure the center axes of film roll and corrugated  
roller come fitting together. (VISUALLY)



## 2-2 Film Loading Procedure

- (1) Switch the mode to manual mode.
- (2) Pull out about 1.5 meters of the film and thread it like a belt as show below:

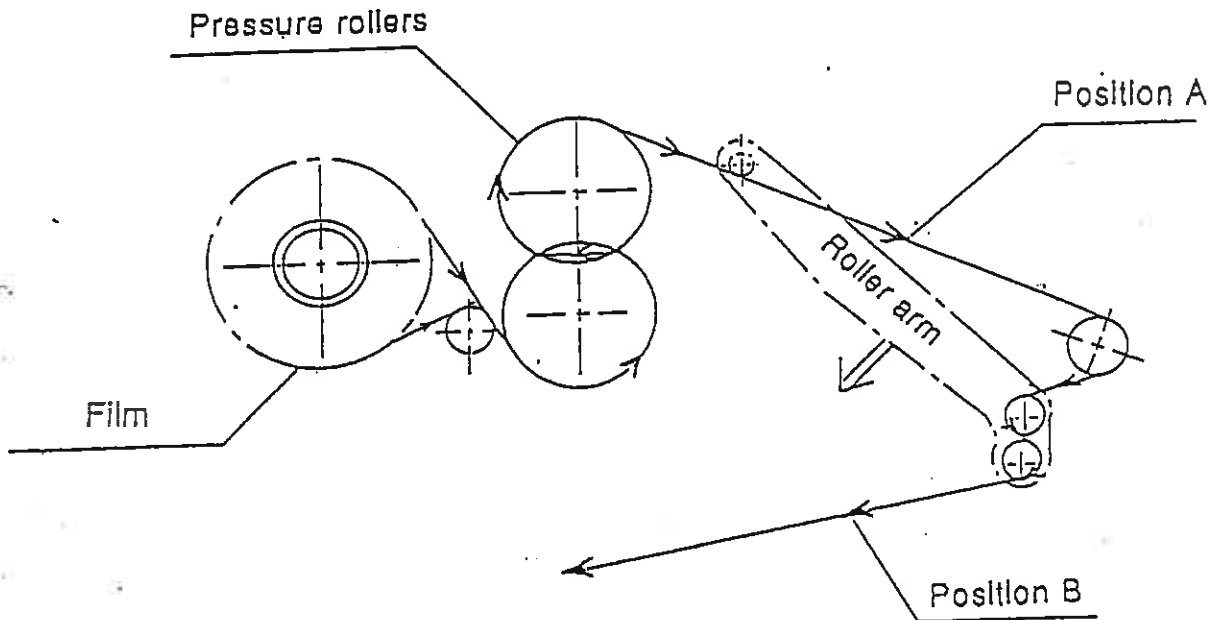

- (3) After having passed the film through to position A, move the roller arm in the direction of the arrow while pulling the film strongly behind the roller arm; the film will come out. Then, thread the film between the runner roller and idle rollers (two sites), pull it out gently from position B and lead it under the product.

Note: When passing the film over the upper surface of the stretch roller; please take care not to touch the bolt.

- Never use cutting knives or edges on stretching roller.
- On setting the film through rollers by hands, if, accidentally, Roller Arm would be moved, corrugated rollers turn automatically. Be careful not to be pinched.

2-3 RELEASE PROCEDURE FROM FILM BLOCK  
(How to wind off film from the rollers)

◇ Procedure

1. First, power OFF.
2. Check how the film was winded up.
3. By hands, turn stretching rollers and wind off the blocking film. (If this is not available, you may try No.4 below.)
4. Cut the film one layer by one at the side of dent of stretching roller.
5. When film was cut off with all dent of rollers, turn the rollers by hands.

◇ Warning

1. Only one person should be engaged in this work. (Many persons on working might cause another trouble such as pinching.)
2. Never use cutting tool on rollers.
3. Use soften or roundish tool made of bamboo, plastic or so. In case the roller got a few flaws, polish with fine sand paper.

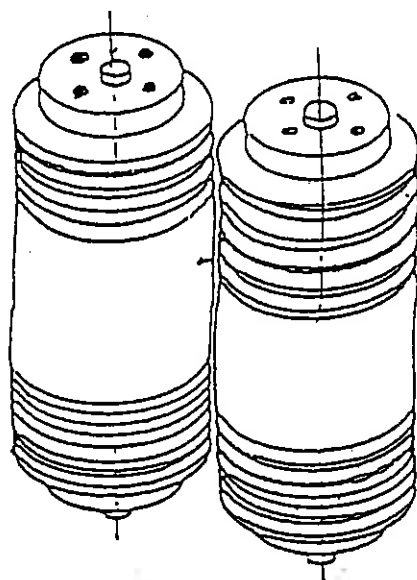

*Cut the film from the side of roller along one dent by one with bamboo or plastic tool as above.*

# Chapter 3: MAINTENANCE

## 3-1 Maintenance List

(Film Supplying Section)

Frequency			Check Point	Items	Method	Measures	Parts Catalog Pg. No.
Daily	3 months	6 months					
	○		General	Modification, damage, corrosion, paint peeling	Visual, "Tapping", Tactile	Re-painting	D 1 ~ D 6
				Loose bolts and pins	Visual, "Tapping"	Tightening	
○			Rubber Roller	Scratch, damage	Visual, Tactile	Removal of damaged section and replacement	D 5
○			Potentiometer	Loose screws	Visual check	Tightening	D 5 ⑨
○			Stretching Roller	Scratch, damage	Visual	Replacement	D 3 ①②

## 3-2 Oils and Lubrication Interval

(Film Supplying System)

Lubrication Point	Parts List Page No.	Method	Amount	Lubricant (Oil)	Lubrication Schedule
Gear Motor	D 3 ⑧⑨	Disassembly, replacement	400g	G r e a s e (Nisseki "Epi-knock" EPO)	5,000 hours
Pillow BLock	D 3 ④ D 5 ⑤	Sealing	1g	G r e a s e (Nisseki "Epi-knock" EPO)	6 months

# Chapter 4: Electric Connection

## 4-1 Standard Wiring Diagram

BYTE X MODEL "BY-10A"

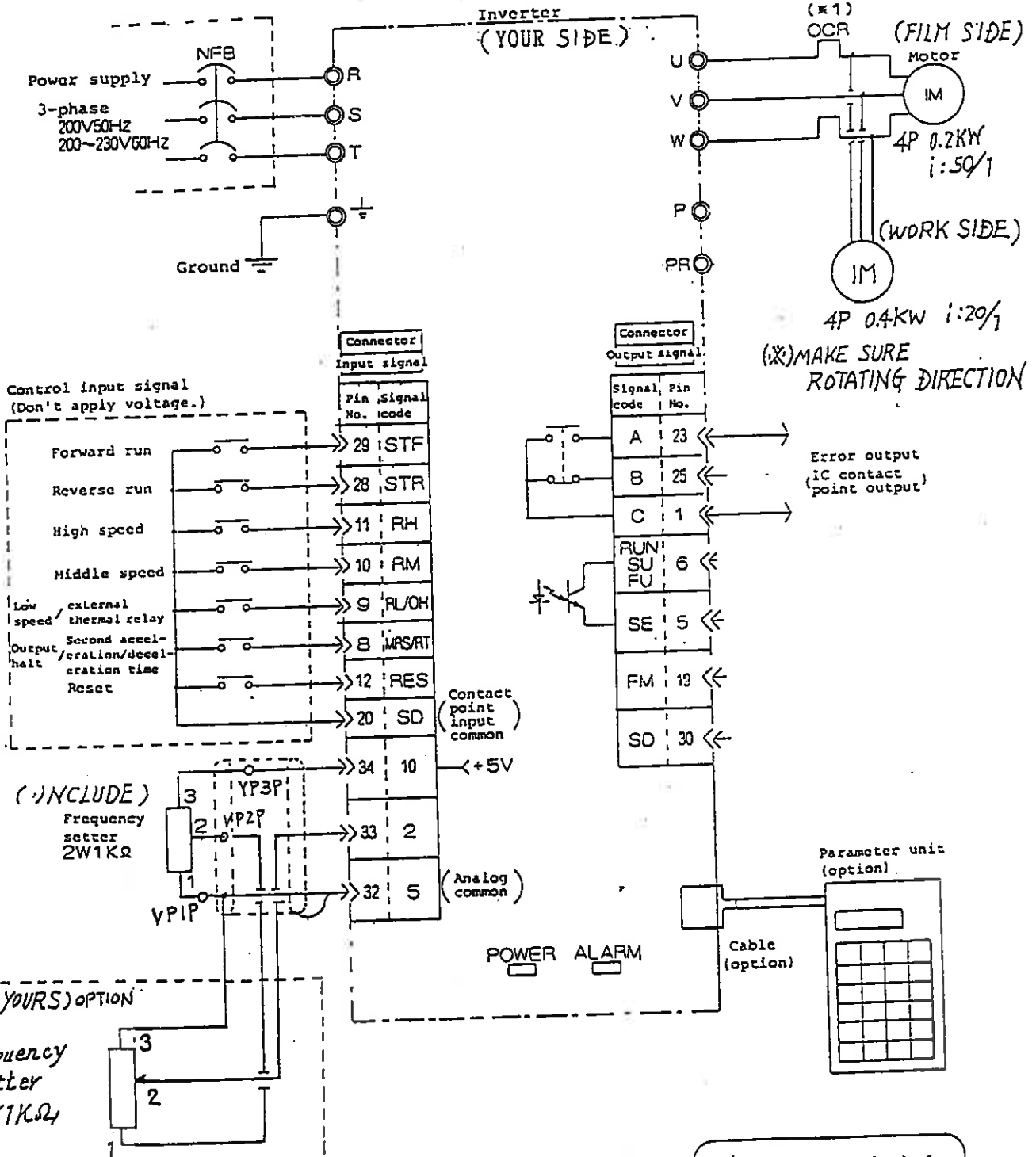
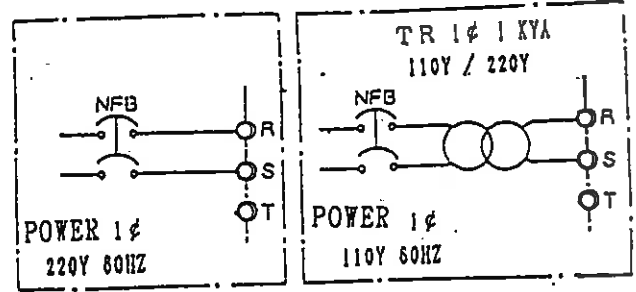

- Note: \*1. Since the electronic thermal function is not provided, the thermal relay shall be externally installed to protect motor from overheat.
- \*2. It is unnecessary when scale is calibrated with parameter unit.

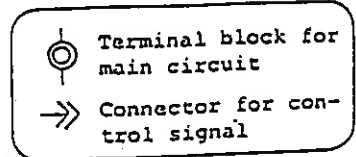

The Inverter with BY-10A has the data which had been inputted factory-set value at delivery as below. Before using this module, please change the values of No.7 & 8 & 20 with Parameter Unit (option).

Input new values

Function No. (parameter)	Function name	Setting range	Factory-set value at delivery from Mitsubishi Electric	BYTEX	
1st function	0	Torque boost (manual)	0~30%	6%	
	1	Max. frequency limit	0~120Hz	120Hz	
	2	Min. frequency limit	0~60Hz	0Hz	
	3	V/F (base frequency)	50~360Hz	60Hz	
	4	3-speed setting (high speed)	0~360Hz	60Hz	
	5	3-speed setting (middle speed)	0~360Hz	30Hz	
	6	3-speed setting (low speed)	0~360Hz	10Hz	
	7	Acceleration time	0.1 ~ 3600 sec.	5 sec.	0.1
8	Deceleration time	0.1 ~ 3600 sec.	5 sec.	0.1	
2nd function	10	PWM mode	0~6	3	
	11	DC dynamic brake time	0~10 sec.	0.5 sec.	
	13	Starting frequency	0.5~10Hz	0.5Hz	
	14	Load pattern selection	0, 1, 2	0	
	17	2nd acceleration/deceleration time	0.1 ~ 3600 sec.	0	
	18	High-speed max. frequency limit	120~360Hz	120Hz	
	20	Frequency at 5V input	1~360Hz	60Hz	250
	24	Multi-speed setting (4 speeds)	0~360Hz, 9999	9999	
	25	Multi-speed setting (5 speeds)	0~360Hz, 9999	9999	
	26	Multi-speed setting (6 speeds)	0~360Hz, 9999	9999	
	27	Multi-speed setting (7 speeds)	0~360Hz, 9999	9999	
	30	Regenerative brake duty	0~30%	3%	
	43	Output frequency detection	0.5 ~ 360Hz	10Hz	
	75	External thermal relay input selection	0, 1	0	
	76	Output signal selection	0, 1, 2	0	
77	Parameter write prohibition selection	0, 1	0		
78	Reversing prevention selection	0, 1, 2	0		
79	Operation mode selection	0, 1, 2	0		
3rd function	C-1	Frequency meter calibration	0~360Hz	60Hz	
	C-2	Frequency setting voltage bias	0~120Hz	0Hz	
	C-3	Frequency setting voltage gain	1~360Hz	60Hz	

Minimum setting unit    Frequency ... 0.01Hz  
                                   Time ..... 0.1 second  
                                   % ..... 1% (however, 0.1% for torque boost)

# PARTS LIST

MODEL BY-10A

N.B.

Film Supplying System "BY-10A" is the assembly module of Film Wrapping Machine "BYTEX". This list is, so, a part of complete machine "YA313H-10A".

YA313H-10A Parts List  
( Film Supplying System )

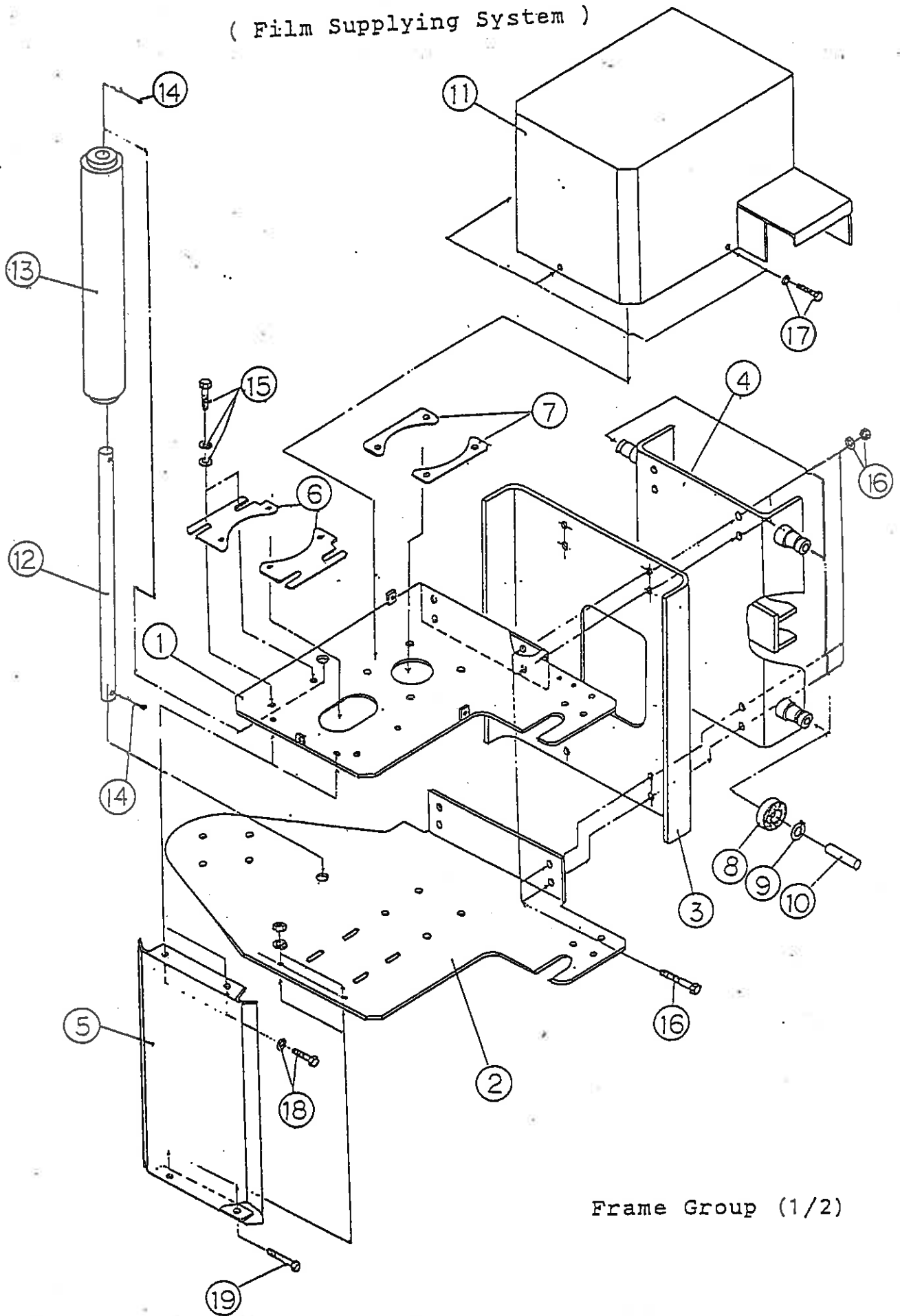

Frame Group (1/2)

## Frame Group (2/2)

CODE	Q'TY	PART No.	PART NAME	REMARKS
1	1	094-073-1050	Upper Board	
2	1	↑ -1040	Lower Board	
3	1	-1070	Side Frame	
4	1	" -1060	Guide Frame	
5	1	-1320	Cover Plate	
6	2	-1160	Slide Plate	
7	2	094-073-1150	Motor Fitting	
8	4	11602-06306	Bearing	
9	4	04064-03015	Snap Ring	
10	4	094-073-1110	Shaft	
11	1	↑ -1330	Head Cover	
12	1	↓ -1120	Roller Shaft	
13	1	094-073-1350	Roller Conveyer (no shaft)	
14	2	04050-00430	Split Pin	
15	4	01010-51020	Bolt	(with flat, spring washer)
16	8	01010-51240	Bolt	(with nut & spring washer)
17	3	01220-00608	Screw	
18	2	01010-50810	Bolt (with spring washer)	
19	2	01010-50820	Bolt (with nut & washer)	



Film Supplier Drive System Group

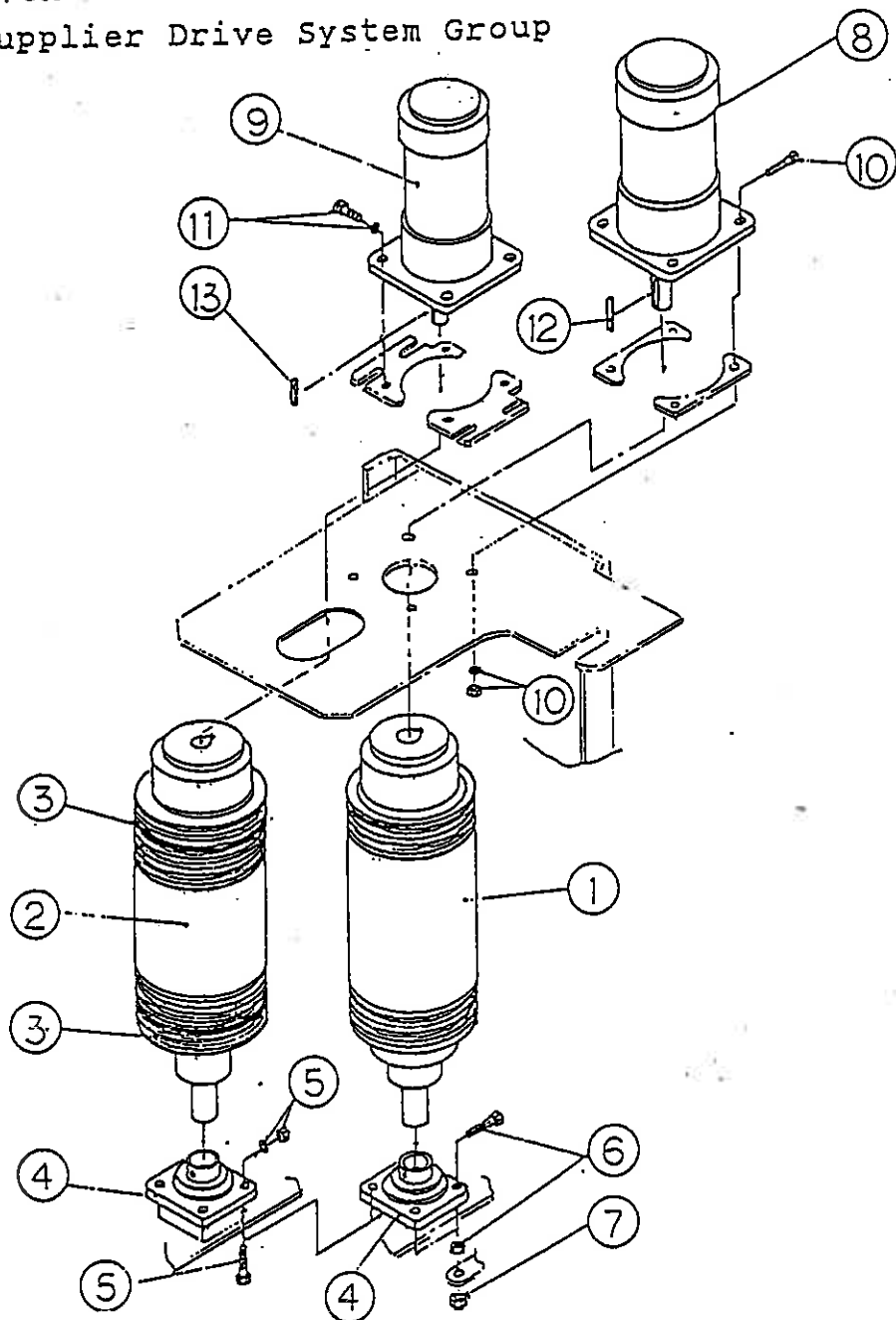

CODE	Q'TY	PART No.	PART NAME	REMARKS
1	1	094-073-1010	Stretching Roller	
2	1	↑ -1020	Stretching Roller	
3	2	↑ -1030	Rubber Belt	
4	2	094-073-1480	Square-Flange Type Ball Bearing	
5	6	01010-51035	Bolt (with nut&washer)	
6	2	01010-51045	Bolt (with nut)	
7	2	094-073-1740	Tough-lock Nut	
8	1	↑ -1450	Motor	
9	1	094-073-1420	Motor	
10	4	01252-41040	Cap Screw (with nut & washer)	
11	4	01252-40815	Cap Screw (with washer)	
12	1	094-073-1460	Key	
13	1	094-073-1430	Key	

フィルムガイドグループ

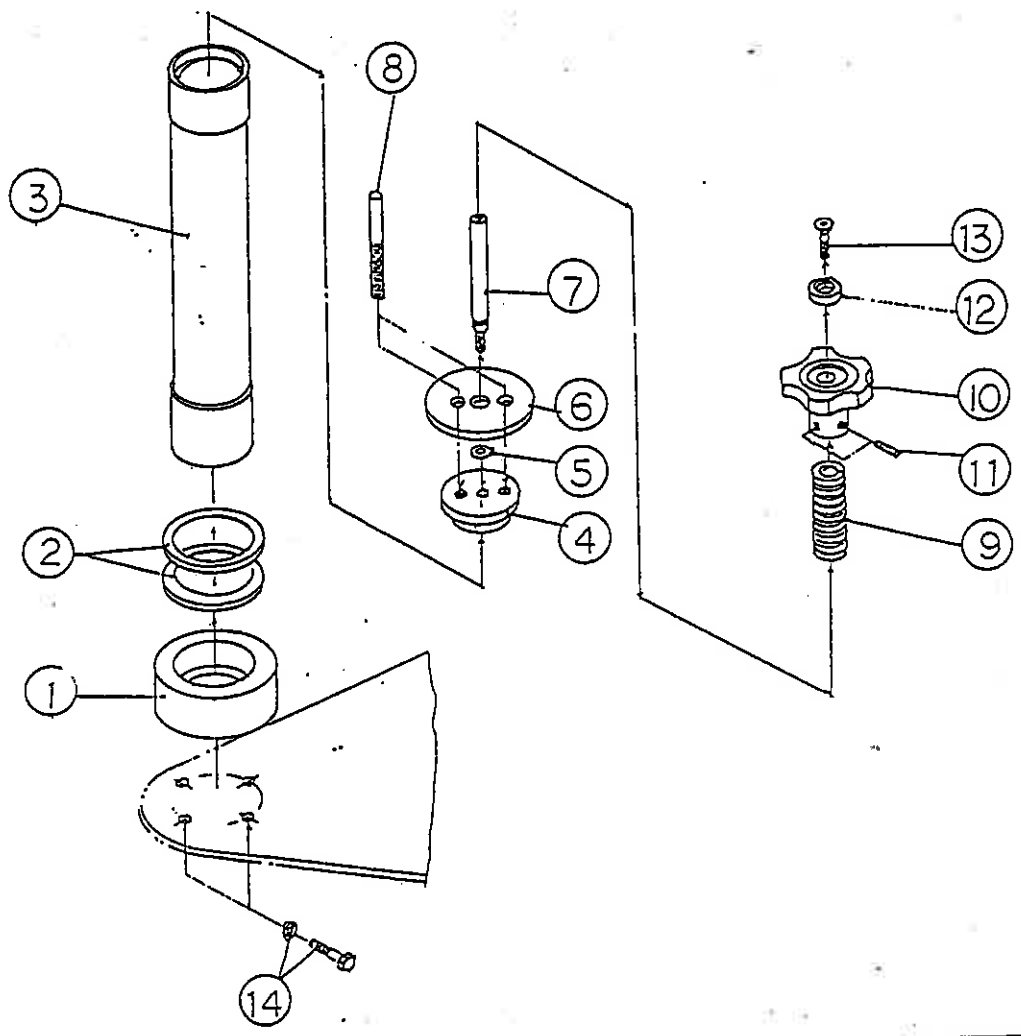

CODE	Q'TY	PART No.	PART NAME	REMARKS
1	1	094-073-1090	Guide Fitting	
2	2	↑ -1100	Slide Plate	
3	1	↓ -1080	Film Guide	
4	1	094-073-1750	Guide Cap	
5	1	04064-01610	Snap Ring	
6	1	094-073-1790	Film Roll Cover	
7	1	↑ -1800	Shaft	
8	2	↓ -1780	Shaft	
9	1	↓ -1820	Spring	
10	1	094-073-1770	Knob	
11	2	01320-40508	Enameled Bolt	
12	1	094-073-1760	Washer	
13	1	01217-50630	Bolt	
14	4	01010-50830	Bolt	(with washer)

Tension Guide System Group (1/2)

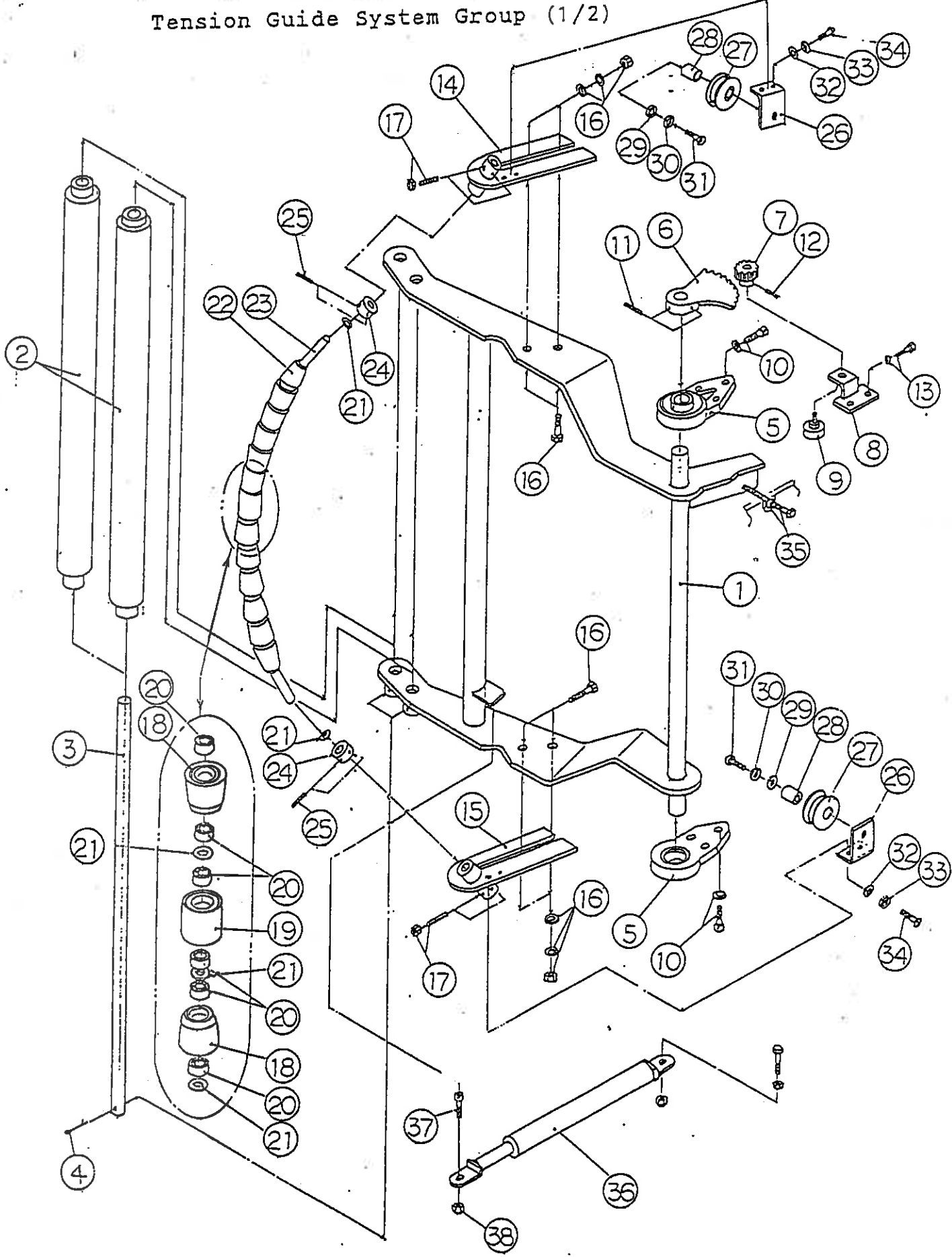

## Tension Guide System Group (2/2)

CODE	Q'TY	PART No.	PART NAME	REMARKS
1	1	094-073-1130	Tension Guide	
2	2	1140	Roller Conveyey	(no shaft)
3	2	094-073-1170	Shaft	
4	2	04050-00430	Split Pin	
5	2	094-073-1550	Flange Type Unit	
6	1	-1260	Sector Gear	
7	1	-1270	Flat Gear	
8	1	-1310	Potentiometer Mount Bracket	
9	1	094-073-1710	Potentiometer	
10	6	01252-20825	Cap Screw	(with washer)
11	2	01320-30418	Enameled Bolt	
12	1	01320-30408	Enameled Bolt	
13	2	01010-50610	Bolt	(with washer)
14	1	094-073-1210	Roller Bracket	
15	1	094-073-1320	Roller Bracket	
16	4	01010-51030	Bolt (with washer&nut)	
17	4	01320-30615	Enameled Bolt	(with nut)
18	10	094-073-1250	Rubber Roller	
19	1	094-073-1240	Rubber Roller	
20	22	11602-06002	Bearing	
21	20	094-073-1220	Washer	
22	2	-1180	Spacer	
23	1	-1200	Shaft	
24	2	-1950	Collar	
25	4	-1960	Enameled Bolt	
26	2	-1870	Bracket	
27	2	-1860	Roll	
28	2	-1880	Collar	
29	2	-1910	Washer	
30	2	-1900	Spring washer	
31	2	-1890	Screw	
32	4	-1940	Washer	
33	4	-1930	Spring Washer	
34	4	094-073-1920	Screw	
35	1	01016-51045	Bolt(whole screwed)	
36	1	094-073-1530	Damper	
37	1	01252-40820	Cap screw	
38	1	094-073-1740	Tough-lock Nut	