



ATTENTION: ♦♦

VERY IMPORTANT

Before unloading and unpacking the machine, read section 5 of this manual for unloading and unpacking instructions.

Failure to do so may result in the forfeiture of the warranty.

L444

OWNER'S
MANUAL

Orion Packaging Inc.
4263 Richelieu
Montreal H4C 1A1
Tel.: 514-937-6642

TABLE OF CONTENTS

1. L44 SPECIFICATIONS	1
2. STANDARD FEATURES	2
3. OPTIONS	3
4. PARTS LISTS	
4.1 Tower Parts List	4
4.2 Carriage Parts List	6
4.3 Base And Turntable Parts List	9
4.4 Electrical Boards	11
5. MACHINE INSPECTION AND INSTALLATION	
5.1 Inspection Upon arrival	12
5.2 Installation	12
6. MACHINE CONTROLS	13
6.1 Power Switch	14
6.2 Start And Stop Switches	14
6.3 Top Cover Switch	14
6.4 Spiral Wrap Switch	15
6.5 Reinforce Wrap/Table Jog Switch	15
6.6 Carriage control switch	15
6.7 Table Speed Control Switch	16
6.8 Photocell Switch	16
7. CYCLE CONTROL SWITCHES	
7.1 Film Tension	17
7.2 Top And Bottom Wraps	17
7.3 Carriage Speed	18

7.4 Turntable Speed Adjustment	18
8. MACHINE MAINTENANCE	
8.1 Speed Reducer Maintenance	20
8.2 Motor Maintenance	20
8.3 Chain Maintenance	21
8.4 Cam Follower Maintenance	21
8.5 Ring Gear Maintenance	22
APPENDIX	23

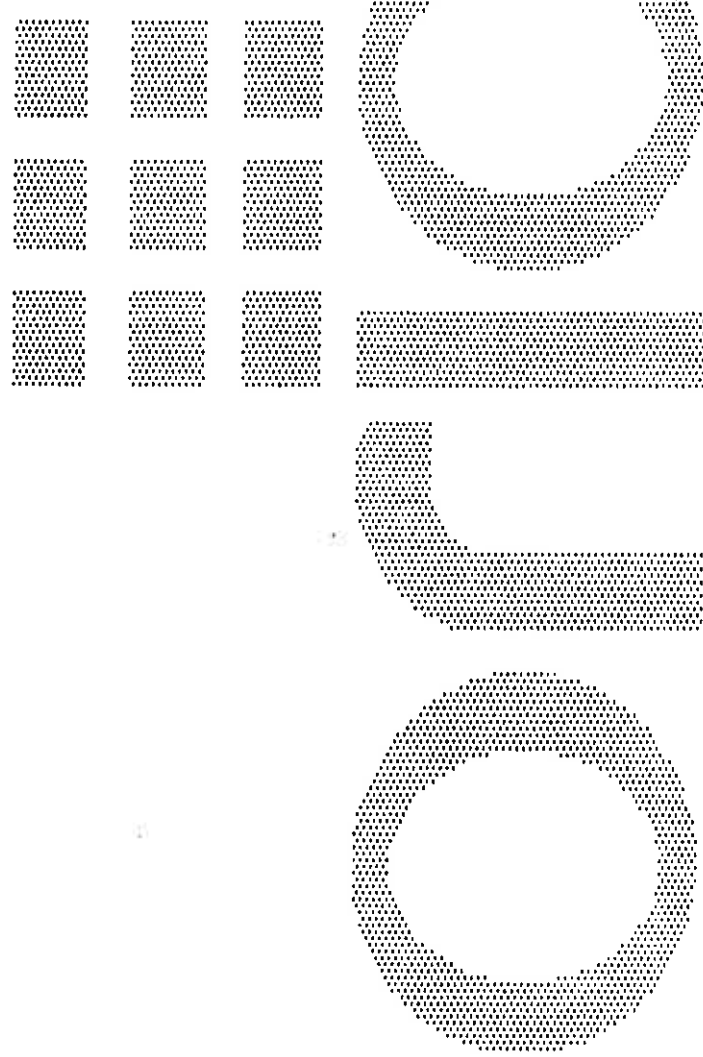

1. L44 SPECIFICATIONS

Power requirements: 110 VAC, single phase, 60 Hz, 15 A

Machine floor space requirements: 60" x 115"

Distance from floor to top of table: 3 7/8 inches.

Turntable diameter: 60" (72" for model S)

Turntable drive: 3/4 hp, 90 VDC, TEFC, SCR controlled soft start and stop, ANSI #50 chain.

Carriage elevator drive: 1/2 hp, 90 VDC, TEFC, SCR controlled variable speed, 35 fpm max, ANSI #50 chain.

Multistretch delivery system: 1/2 hp, 90 VDC, TEFC, SCR controlled force to load compensation by a dancer bar.

Maximum static load: 30 000 lbs.

Maximum dynamic load: 6 000 lbs.

Minimum load: 350 lbs.

Maximum pallet and load dimensions: 80" x 80" x 96" (height with 30" film)

Machine dimensions: 60" x 115" x 92" (h)

Machine weight: 2450 lbs.

STANDARD FEATURES

The standard L44 stretchwrapper comes with Multistretch powered prestretch film delivery system accomodating up to 30" film without changing the film mandrel. It works with an active dancer system with quick response that regulates the prestretch feed in order to keep a constant film tension.

The master control panel features are,

- Film tension control,
- Individual count selectors for top and botom wraps,
- Individual controls for elevator up and down speed control,
- Electric eye OFF/ON,
- Top cover pause selector,
- Spiral up - up/down wrap pattern selector,
- Reinforce wrap, Turntable jog,
- Raise/Lower elevator control,
- High/Low turntable speed selector,
- Power OFF/ON
- Start,
- Stop,
- Circuit breaker protection.

The turntable has positive alignment and an adjustable speed of up to 16 rpm with an adjustable acceleration and deceleration independent of a high or low speed selection.

The turntable is supported by twelve cam followers, mounted in 1/2 inch steel, each having a maximum static load capacity of 2500 lbs.

3.

OPTIONS

The options available for the Standard, Low Profile stretchwrapper are,

- Ring gear turntable drive and support system
- 72" diameter turntable,
- Turntable surrounding
- Extended mast,
- Dual turntable,
- Programmable logic controller,
- Heater option for cold environment application,
- Custom design features

Custom design features may be in the form of special brackets or tracks that hold loads that don't require pallets, or additional features such as scales to measure the load's weight as it is being wrapped.

4. PARTS LISTS

4.1 Tower Parts List

The exploded assembly drawing of the Standard Tower is shown on drawing number 200 99. Table 1 has the parts listed in order of part number. Note: the names given to the parts are generic.

TABLE 1

Tower Parts List

Part Number	Description	Quantity
10008	Idler sprocket	1
10009	#50 chain	1
10010	Cam follower (1 3/8 inch O.D.)	6
10018	Left carriage holder	1
10019	Right carriage holder	1
10063	Tower	1
10067	Cam follower (1/2 inch O.D.)	4
10069	Chain tensioner	1
10070	Chain tensioning screw	2
10071	Limit switch actuator	1
10074	Drive sprocket	1
10076	Limit switch channel	1
10081	Chain cover	1
10087	Limit switch bracket	3
10091	Channel guide	3

10092	Knob	3
10093	Reducer	1
10095	Elevator motor (1/2 hp, 1750 rpm)	1
10123	Limit switch	3
10288	1/4-20 UNC x 1/2 SHCS	2
10289	Limit switch screw	6
10290	Channel screw (1/4-20 UNC x 1/2 SHCS)	2
10291	Transmission screw (3/8-16 UNC x 1 Hex bolt)	4
10292	Chain tensioner pin	2
10293	3/8-16 UNC x 3/4 Hex bolt	2
10294	Cover screw (1/4-20 UNC x 1/2 SHCS)	3
10295	3/16 inch square key	1

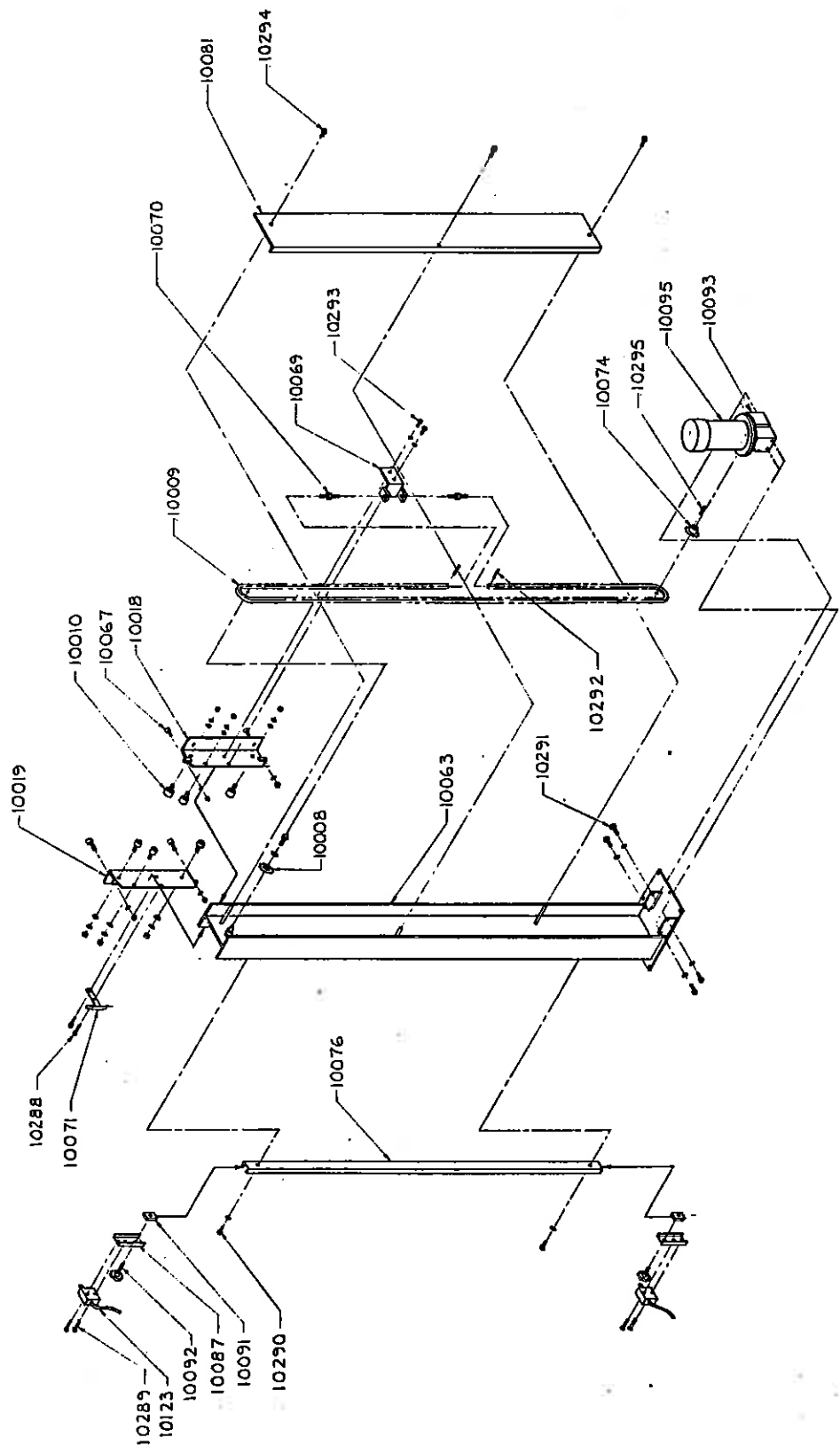

ORION PACEMAKER MONTREAL	
REV.	DATE
1	10/1/83
STD. TOWER ASSY	
LEE 444 LES 455 9433 100-83	

4.2 Carriage Parts List





The exploded assembly drawing of the Standard carriage is shown on drawing number 200 100.

Table 2 has the parts listed in order of part number. Note: the names given to the parts are generic.

TABLE 2

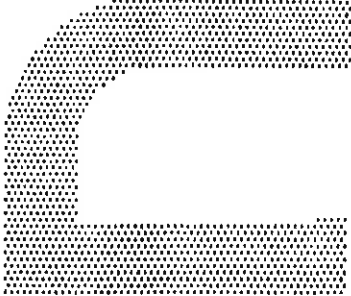
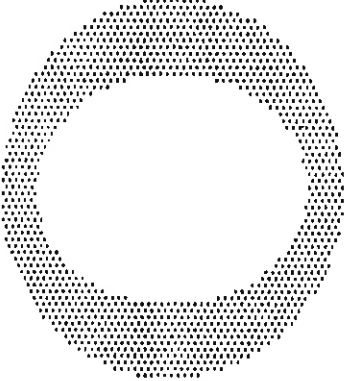
Carriage Parts List

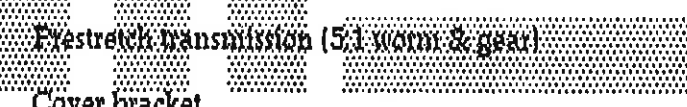
Part Number	Description	Quantity
10010	Cam follower (1 3/8 inch O.D.)	1
10015	20" Carriage frame	1
10016	30" Carriage frame	1
10017	Roller bracket	1
10020	Multistretch mechanism cover	1
10021	Spacer	1
10022	Belt tensioner	1
10023	30" Pressure roller	1
10024	20" Pressure roller	1
10026	30" Center dancer roller	1
10027	30" Roller	1
10030	Top dancer lever	1
10031	Bottom dancer lever	1
10033	20" Center dancer roller	1
10034	20" Roller	1
10037	30" x 3" dia. rubber roller	1
10038	30" x 4" dia. rubber roller	1
10039	20" x 3" dia. rubber roller	1

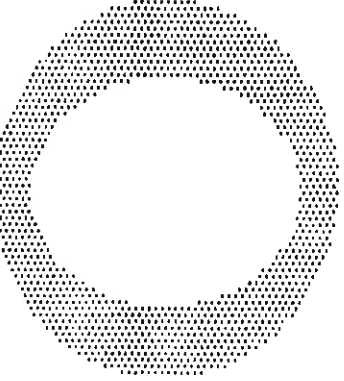
10040	20" x 4" dia. rubber roller		1
10042	3/4" flanged bearing unit		2
10043	1" Pillow block		1
10044	Prestretch driver pulley		1
10045	Potentiometer coupling		1
10046	Potentiometer bracket		1
10047	Film tension spring		2
10048	Spring adjustment screw		2
10049	Brake pad		2
10050	Film spool mandrel		1
10051	Top mandrel		1
10052	1" Collar		6
10054	Bottom mandrel		1
10058	Bronze bushing		2
10061	Prestretch transmission (5:1 worm & gear)		1
10068	Cover bracket		2
10091	Channel guide		1
10092	Knob		1
10118	Photoswitch		1
10121	Channel bracket		1
10122	30" Channel		1
10133	Prestretch driven pulley		1
10146	Timing belt		1
10155	20" Channel		1
10156	Photoswitch bracket		1
10157	3/4 inch pillow block		1
10227	3/16 inch square key		1

10296	Channel screw	2
10297	3/16 inch square key	1
10298	3/8-16 UNC x 1 long hex bolt	2
10299	Multistretch cover screw	3
10300	3/8-16 UNC x 2 long SHCS	1
10301	5/16-18 UNC x 2 1/2 long Hex bolt	4
10302	8-32 UNC x 1/2 long BHCS	8
10303	Bumper	2
10304	10-24 UNC x 3/4 long SHCS	2
10305	5/16-18 UNC x 3/4 long SHCS	2
10306	1/4-20 UNC x 3/4 long CHCS	2
10307	Feedback potentiometer	1
10308	10-24 UNC x 1/2 long SHCS	2
10309	1/4" square key	1
10310	10-24 UNC x 1 long SHCS	2
10368	3/8-16 UNC x 1 long hex bolt	4
10425	3/4" collar	1
30095	Prestretch motor (1/2 hp, 1750 rpm)	1

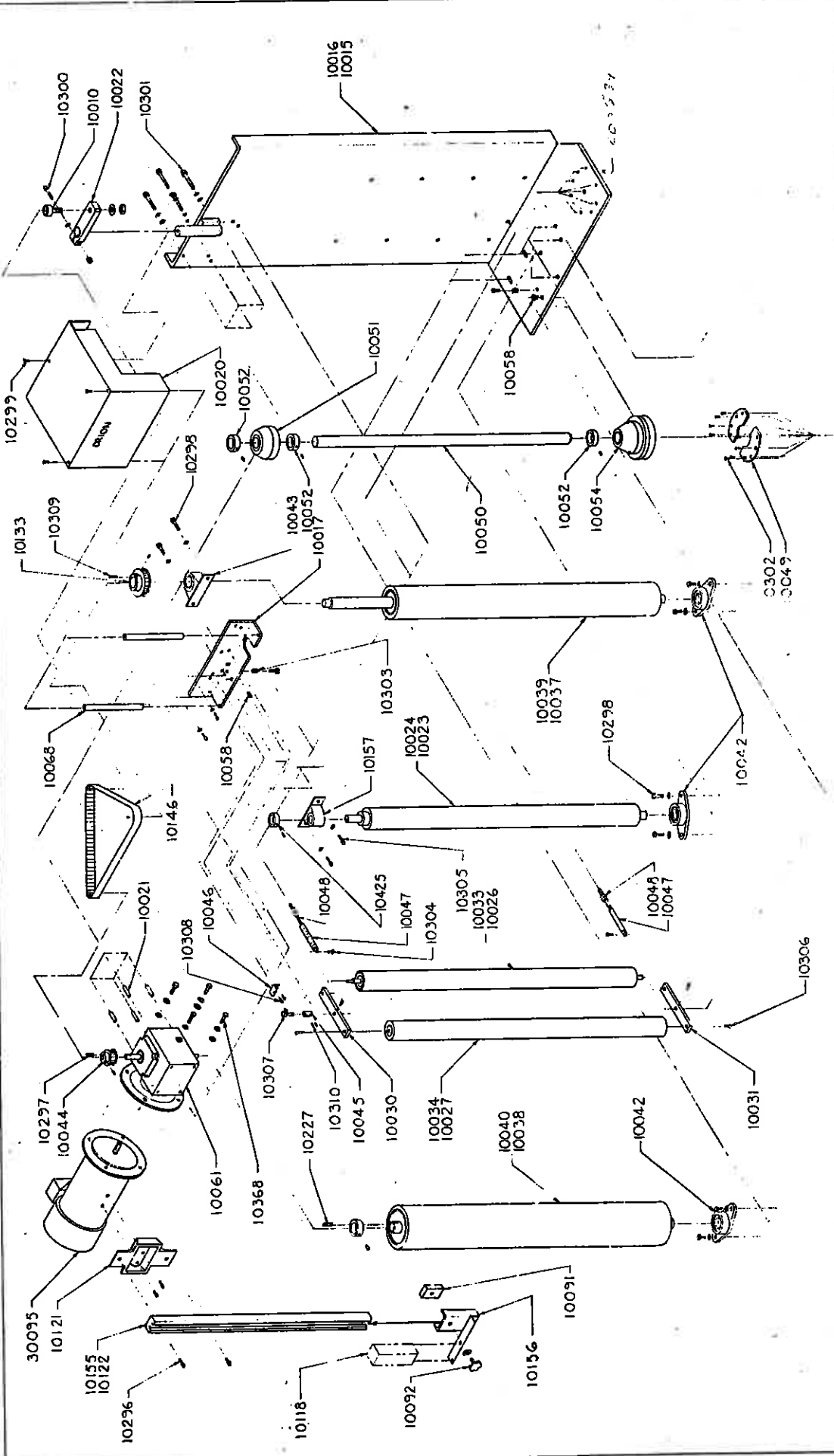

OFFICE: BRIDGEVILLE, MONTREAL	
DATE: 10/1/53	BY: J. G. B.
REV. CARRIAGE: 4331V	
44 55 56 PA33 PA33 1750	

4.3 Base And Turntable Parts List

The exploded assembly drawing of the Standard, Low Profile base is shown on drawing number 200

98. Table 3 has the parts listed in order of part number. Note the names given to the parts are generic.

TABLE 3

Base And Turntable Parts List

Part Number	Description	Quantity
10001	Base	1
10002	Chain tensioner	1
10003	Tensioning screw	1
10004	Chain cover	1
10006	Turntable sprocket	1
10007	Center bearing unit	1
10008	Idler sprocket	2
10009	#50 chain	1
10010	Cam follower	12
10012	Turntable	1
10032	3/4 hp motor (44)	1
10035	Reducer	1
10036	1/2 hp motor (55)	1
10088	Proximity switch bracket	1
10124	Proximity switch	1
10094	Driver sprocket (44)	1
10119	Driver sprocket (55)	1
10321	3/8-16 UNC x 1 1/2 long SHCS	4

10322	3/8-16 UNC x 1 1/2 long hex bolts	4
10323	Proximity switch screw	2
10324	3/8-16 UNC x 1 1/2 long hex bolt	1
10325	3/8-16 UNC x 1 1/2 long hex bolt	1
10326	3/8-16 UNC x 1 long CHCS	3
10327	Roping bar	1
10328	Roping bar stand	2
10329	5/8-11 UNC x 1 1/2 long hex bolt	2
10368	3/8-16 UNC x 1 long hex bolt	4
10455	5/16-18 UNC x 1 long hex bolt	4
10456	10-24 UNC x 1 long CHCS	3

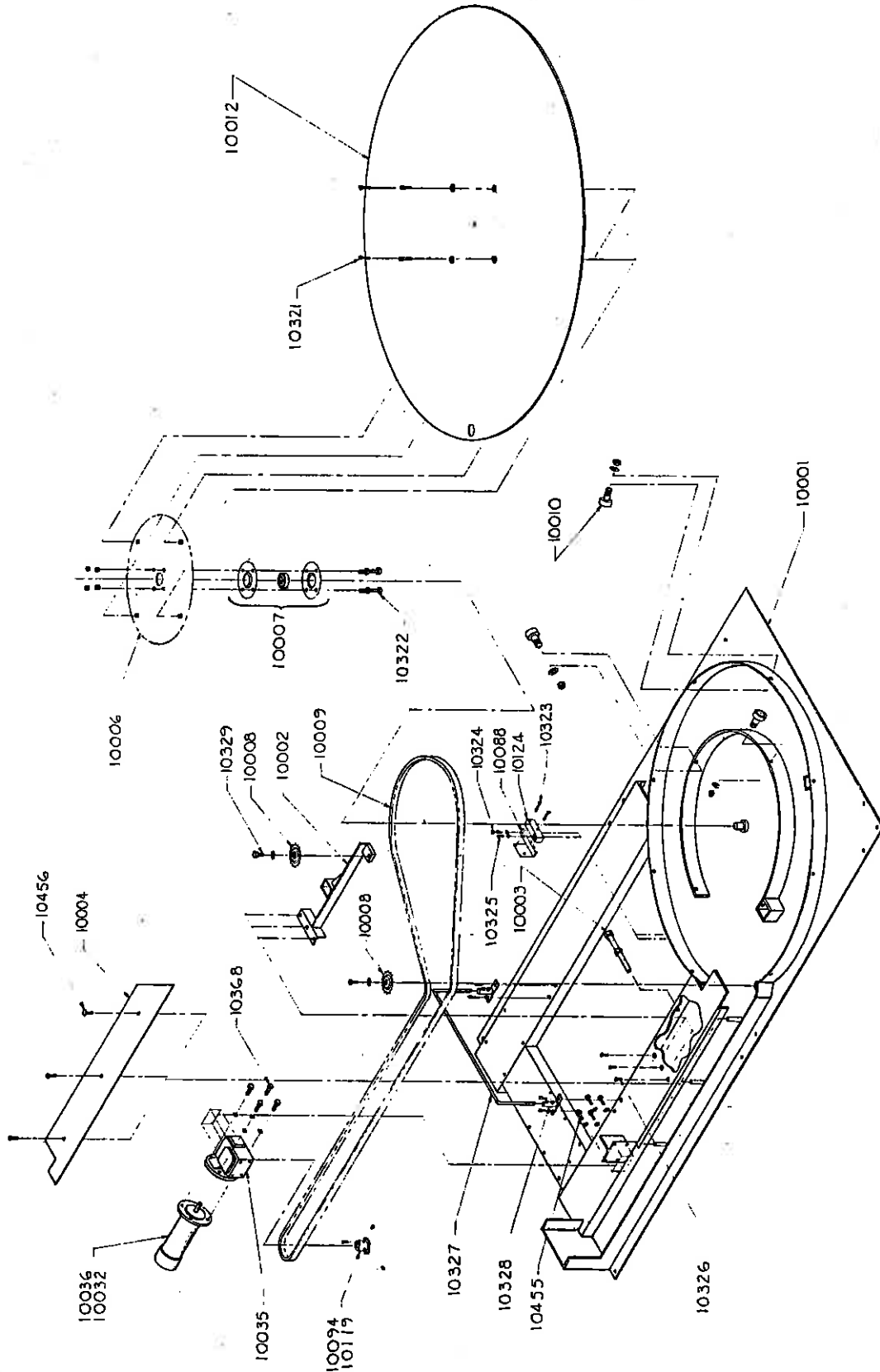

ORIGIN	RECORDING	MONTREAL
DATE	10-17-80	
BY	10-17-80	
3TD	LOWE	ANGELLE
BASE	ASST	
L44	L35	200-78

4.4 Electrical Boards

The standard L44 stretchwrapper panel box contains the following electrical control boards:

750+233
236
155-3A
168-4 (168-3)

The drawings of the face of these boards with the relevant output and input terminals and adjustment potentiometer locations are shown in the appendix.

A more detailed account of the adjustments possible on the 750+233 board is given in section 7.4 of this manual.

If the stretchwrapper is controlled with a PLC (Programmable Logic Controller) the boards used are:

750+233
236
168-4

The drawings of the faces of these boards will be placed in the appendix for a PLC controlled stretchwrapper.

5. MACHINE INSPECTION AND INSTALLATION

5.1 Inspection Upon Arrival

CAUTION: When unloading the stretchwrapper, care must be taken not to lift it by the turntable. The forks of the forklift should be inserted in the 10 inch slots behind the tower to lift the machine.

Before inspection, all packing and restraining blocks must be removed; these may include the blocks under the carriage and the bolts holding the ramp on the table.

CAUTION: When cutting the stretchwrap material covering the machine, care must be taken not to cut any of the electrical lines.

A visual inspection of all the electrical connections should be performed after unpacking the machine to check for loosened joints or broken connections. Any suspected shipping damage must be reported immediately to the freight carrier.

Items that are vulnerable to damage and must be inspected are the motor and transmission housings and connections at the base of the tower, and on the carriage, the photoswitch on the carriage, and the roping bar and stands.

5.2 Machine Installation

After the visual inspection has been performed, the customer is required to provide the electrical power requirements as outlined in the specifications (sections 1, 2, and 3 of this manual).

An electrical diagram is provided in the panel box. Only a qualified electrical technician or an Orion representative should effect any repairs on the machine.

Before operating the machine the oil pockets underneath the table should be checked and filled if any oil is missing (see section 8.4).

6.1 Power Switch

The Power Switch has two settings,

ON - Connects a 110 VAC power source to the machine.

OFF - Disconnects the power source.

Turning the power switch ON causes the POWER light to turn on.

6.2 Start And Stop Switches

The Start switch is used to start the cycle once the load is on the turntable. The cycle may be stopped at any time by pressing the Stop button.

NOTE: if the Stop button is pressed in the middle of the cycle, the carriage and turntable must be returned back to their home positions by using the jog buttons before restarting the cycle.

6.3 Top Cover Switch

The Top Cover switch has two positions,

WITH - In the WITH position the cycle will stop after one top wrap is completed, allowing the placement of a top sheet on the load, after which the start button may be pressed to resume wrapping.

WITHOUT - In the WITHOUT position the cycle will not pause for the placement of a top cover.

6.4 Spiral Wrap Switch

The Spiral Wrap switch has two positions,

UP - In the UP position the cycle will end after completing the specified number of top wraps, therefore, the machine will only wrap the load once, going up.

UP/DOWN - In the UP/DOWN position the cycle is complete after the load is wrapped in both the up and down directions.

6.5 Reinf. Wrap/Table Jog Switch

This switch has three positions,

middle position - in this position the switch is inactive and the machine will operate normally.

Reinf. Wrap - when the switch is held in this position during operation the carriage will stop rising or descending in order to increase the number of wraps around the chosen section.

Table Jog - when the switch is held in this position the turntable will turn in a clockwise direction as viewed from the top. The table jog is inoperative during the wrap cycle.

6.6 Carriage Control Switch

The Carriage Control switch is a monostable three position switch with the following settings,

RAISE - Raises the carriage until the top limit switch on the tower is activated or until the photoswitch

senses that the top of the load has been reached.

LOWER - Lowers the carriage until the bottom limit switch on the tower is activated.

The switch is normally in the middle position where the carriage remains stationary. Turning the switch to the RAISE or LOWER position will activate the carriage to move in its respective direction.

6.7 Table Speed Control Switch

The Table Speed Control switch has two settings.

LOW - The LOW setting may be used for wrapping unstable or very heavy loads that tend to fall apart when wrapped at higher speeds.

HIGH - The HIGH setting may be used for wrapping more stable loads. Once the up wrap has been wrapped on the low speed setting, unstable loads may also be wrapped on the high speed setting by switching from LOW to HIGH after the top wraps are done.

6.8 Photocell Switch

The Photocell switch has two settings,

ON - When turned ON, the photocell senses whether or not the carriage has reached the top of the load. The carriage will stop and begin the top wraps sequence once the top of the load is reached. The carriage will always stop at the top of the load regardless of its height. The photoswitch's position on the track can be adjusted in order to make the carriage pass the top of the load and overlap the top.

OFF - When turned OFF, the photocell is inoperative and the carriage will stop only once the top limit switch has been activated.

7.

CYCLE CONTROLS

7.1 Film Tension

The film tension may be adjusted through the film tension control potentiometer. The pot has a range of tension from 0 to 10, 10 being the highest tension rating. This pot may be adjusted during the cycle.

CAUTION: Light loads may require lower tension settings than heavier loads.

The film tension is controlled through the dancer bar system. Occasionally the feedback potentiometer may need some adjustment. The adjustment of the feedback potentiometer can be performed while there is no film on the carriage. The bottom screw on the potentiometer coupling must first be loosened. Once the screw is loosened the potentiometer shaft must be turned until the pressure motor just begins to hum but does not rotate, at which point the screw can be tightened. NOTE: the condition in which the motor hums but doesn't turn must be maintained even after the screw is tightened, if not the adjustment procedure must be repeated.

7.2 Carriage Speed

There are two carriage speed controls on the panel,

CARRIAGE SPEED UP,
CARRIAGE SPEED DOWN.

The carriage speed controls can be used to control the amount of overlap the film will have on itself during a wrap. It is recommended to start with a RAPID upward wrap in order to stabilize the load early in the cycle.

The control potentiometers have settings from 0 to 10, the higher settings being the fastest. High settings will mean less film overlap because of faster carriage speed, and low settings will mean more film overlap because of lower carriage speeds.

7.3 Top And Bottom Wraps

There are two multi-position switches which control the number of wraps that may be put at the top and bottom of the load. Each switch has positions going from 1 to 10 corresponding to the number of wraps which may be applied at the top or bottom of the load.

These switches may be set before the cycle begins.

7.4 Turntable Speed Adjustments

The turntable speed may be changed by adjusting the controls on the 750+233 board inside the panel. The controls on the board regulate the steady-state speed, the jog speed, and the acceleration and deceleration of the turntable. The controls are labeled on the board and listed below:

ZERO - The zero adjustment controls the deadband voltage for the turntable motor; it should be adjusted so that the motor just begins to hum but does not turn.

PRESET 1 - The preset 1 controls the HIGH speed of the turntable.

PRESET 2 - The preset 2 controls the jog speed of the turntable.

PRESET 3 - The preset 3 controls the LOW speed of the turntable.

DN 1 - The DN 1 adjustment regulates the rate of deceleration of the turntable for when it reaches the end of the cycle at the HIGH speed.

DN 3 - The DN 3 adjustment regulates the rate of deceleration of the turntable for when it reaches the end of the cycle at the LOW speed.

UP - The UP adjustment regulates the rate of acceleration of the turntable for the beginning of the cycle.

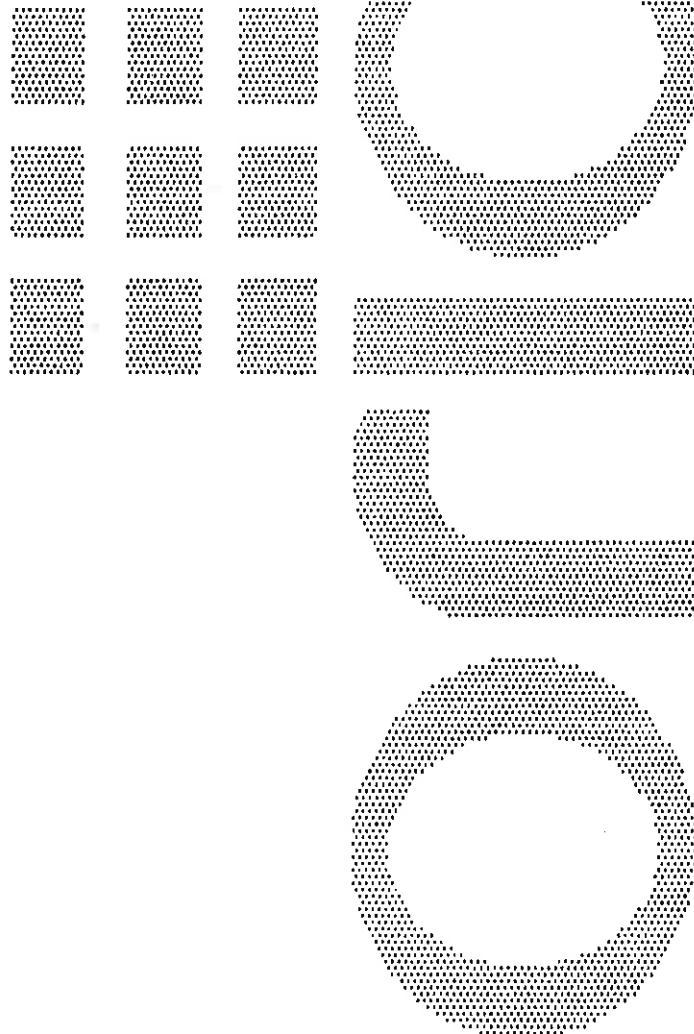

8. MACHINE MAINTENANCE

8.1 Speed Reducer Maintenance

On the reducing transmission, after the first week all external cap screws and plugs should be checked for tightness. It is recommended to change the oil every six months or every 2500 hours of operation, whichever comes first. When adding oil the transmission should never be filled above the oil level mark indicated because leakage and overheating may occur. Below is a list of the type of lubricant that should be used.

Manufacturer	Lubricant
American Oil Co.	American Cyl. Oil No. 196-L
Cities Service Oil Co.	Citgo Cyl. Oil 180-S
Gulf Oil Corp.	Gulf Senate 135
Mobile Oil Corp.	Mobil 600 W Super Cyl. Oil
Phillips Oil Co.	Andes S180
Texaco Inc.	624-650T Cyl. Oil
Shell Oil Co.	Velvata Oil J82
Union Oil Of Cal.	Red Line Worm Gear Lube 140

Reducing transmissions are found on the carriage, and at the base of the tower.

8.2 Motor Maintenance

An occasional inspection of the brushes should be made in order to establish a wear rate. Replacement brushes should be installed before old brushes wear to 9/16" long, measured on the long side. After

replacing brushes run the motor near rated speed for at least 1/2 hour with no load to seat the new brushes. Failure to properly seat the new brushes may cause commutator damage and rapid wear of the new brushes. If the commutator becomes rough, scored, or out of round, a competent motor shop should disassemble the motor and resurface the commutator. With every third brush change, have a competent motor shop resurface the commutator and blow the carbon dust out of the motor.

8.3 Chain Maintenance

To clean and relubricate chains, wipe them with an oily cloth every month. If the environment is very dusty or damp, it may be necessary to clean and relubricate the chains more often.

With time the chains will tend to stretch. A loose elevator chain should be tightened at the chain tensioner as shown on drawing number 200-192. A loose turntable drive chain should be tightened by tightening the 1" dia. screw on the base, next to the turntable.

8.4 Cam Follower Maintenance

The cam followers behind the carriage have deep grease pockets and do not need frequent relubrication.

The portion of the tower on which the cam followers roll should be cleaned and regreased every 300 hours of operation. If the machine operates in a dusty or corrosive environment the tower should be relubricated more often.

The cam followers under the turntable are wet with oil in order to keep the track properly lubricated. The oil pockets should be refilled every 200 hours of operation. The two oil pockets are found on the base, underneath the table.

8.5 Ring Gear Maintenance

If the stretchwrapper has the optional ring gear turntable drive and support system, this maintenance routine must be performed.

The ring gear is located under the turntable and should be lubricated at fixed intervals. This should be carried out by injecting grease into all the lubrication nipples in succession until a collar of fresh grease appears around the perimeter of both sealing rings. The bearing could be rotated slowly during lubrication.

The relubrication interval depends on the operating conditions. For bearings exposed to an aggressive environment, relubrication should occur every 50 operating hours. Normally, relubrication should occur every 100 to 200 hours of operation. The gear teeth should also be relubricated. Lubricants of different manufacture recommended for the ring gear are shown below.

Manufacturer	Raceway Grease	Gear Teeth Oil
BP	Energreat LS 2	Energol WRL
Castrol	Spherol AP 2	Grippa 33 S
ESSO	Eacon 2	Surret Fluid 30
Gulf	Crown Grease No.2	Lubcote No.2
Mobil	Mobilux 2	Mobiltac E
SHELL	Alvania Grease R 2	Cardium Compound C/Fluid C
Texaco	Glissando FT 2	Crater 2 X Fluid
Valvoline	LB-2	FGC

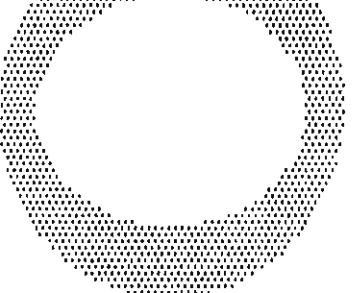
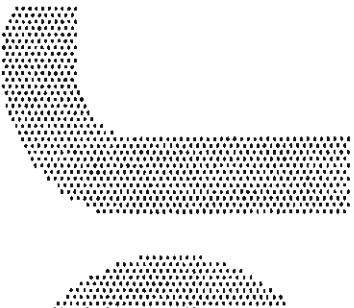
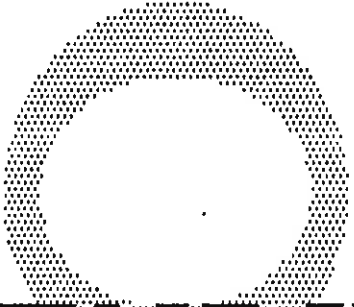
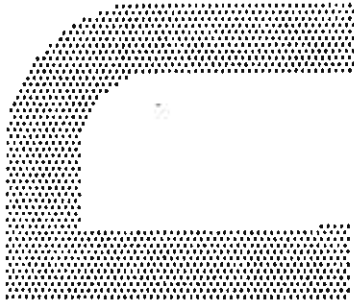

APPENDIX

ORION MULTISTRETCH

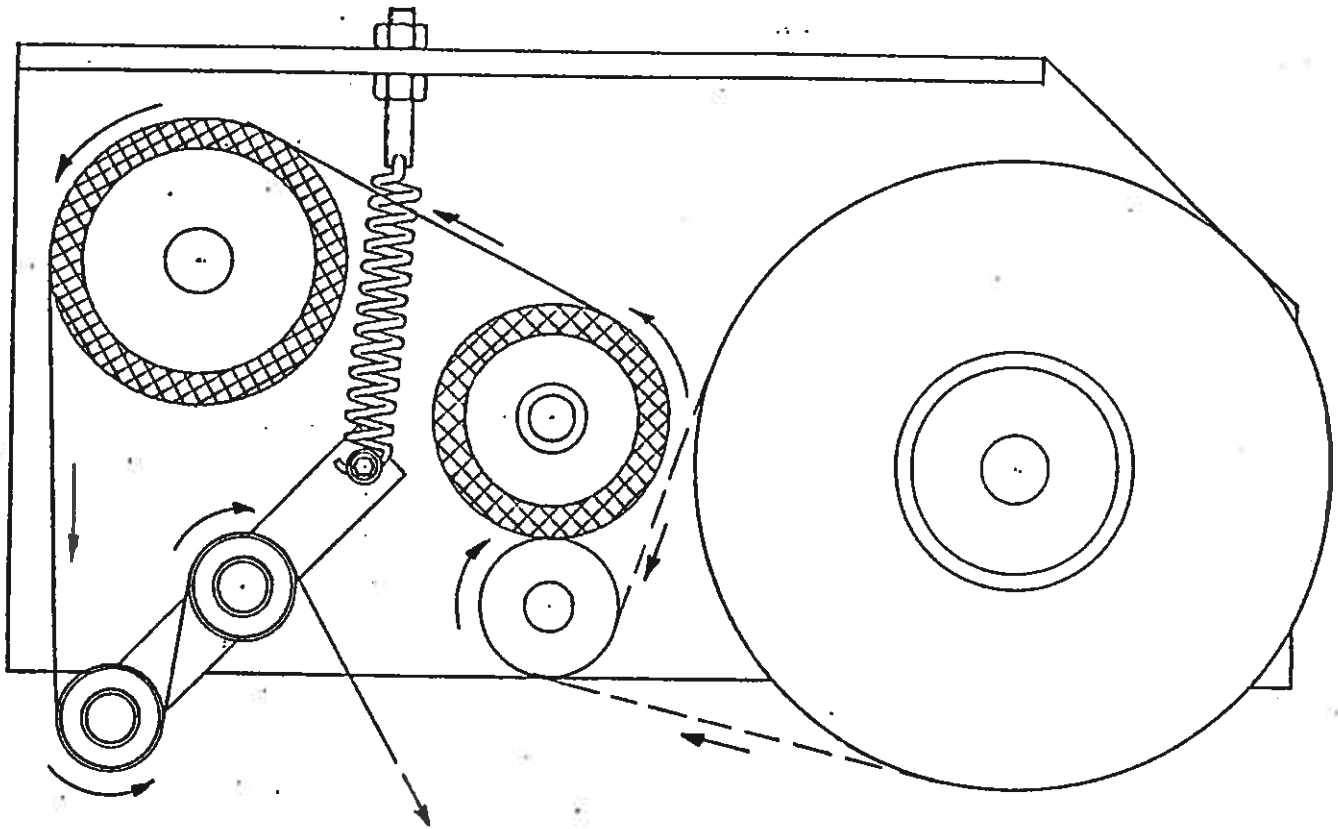

DISCONNECT POWER BEFORE FEEDING

This diagram shows the pattern the film must take around the rollers for the proper operation of the stretchwrapper.

WARNING: The machine must be disconnected from the power source before the film is fed through the rollers. Failure to do this may result in serious injury to the operator and damage to the machine.

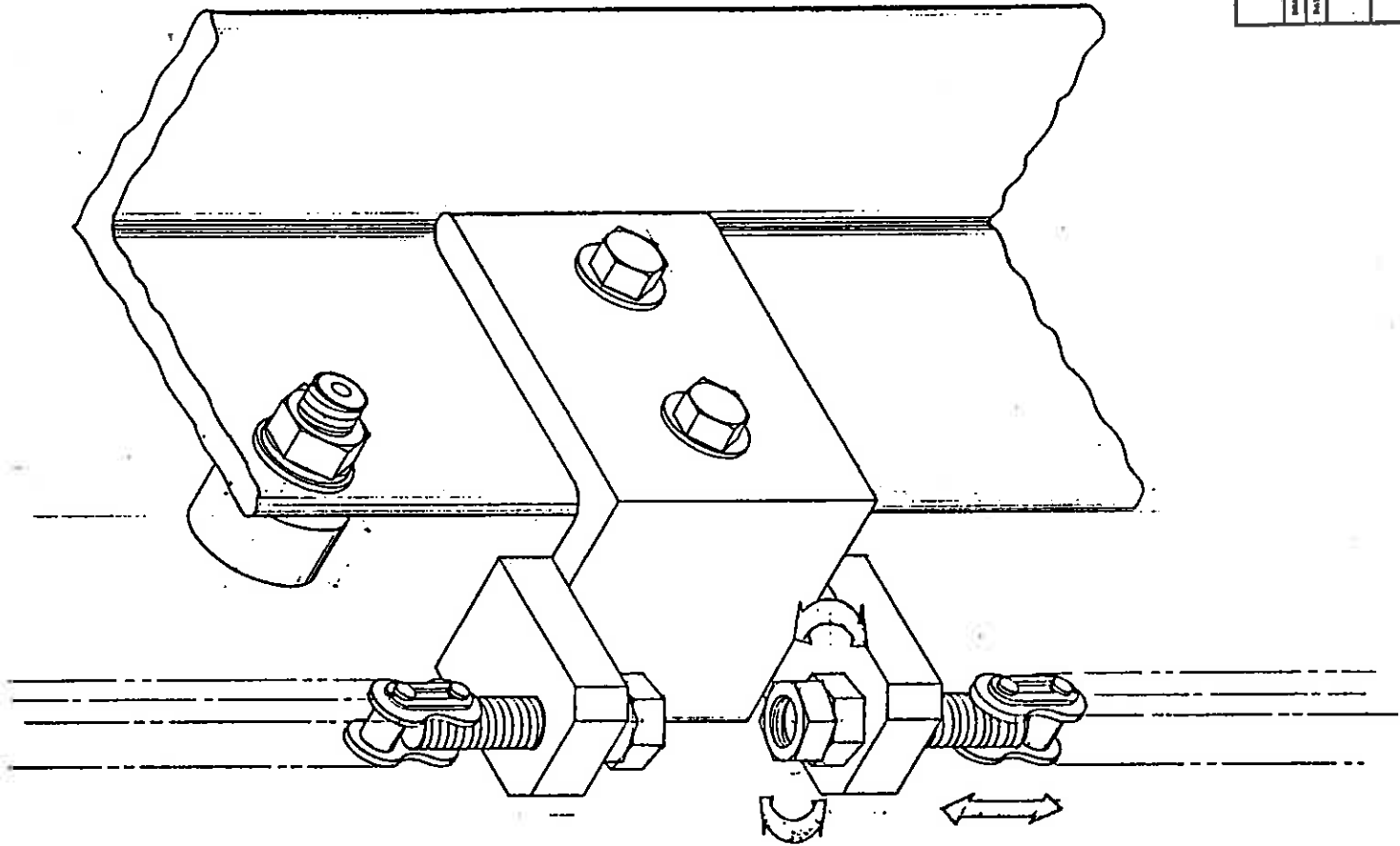

CHAIN TENSION
ADJUSTMENT

ORION PACKAGING		DESIGNED BY W.A.L.E.A./J.M.
REVISED N.T.S.	APPROVED BY	DATE
10-7-55		
CHAIN TENSIONER ASS'Y		PRODUCTION NUMBER
		200-192

Motor dimensions

TEFC P/M motor

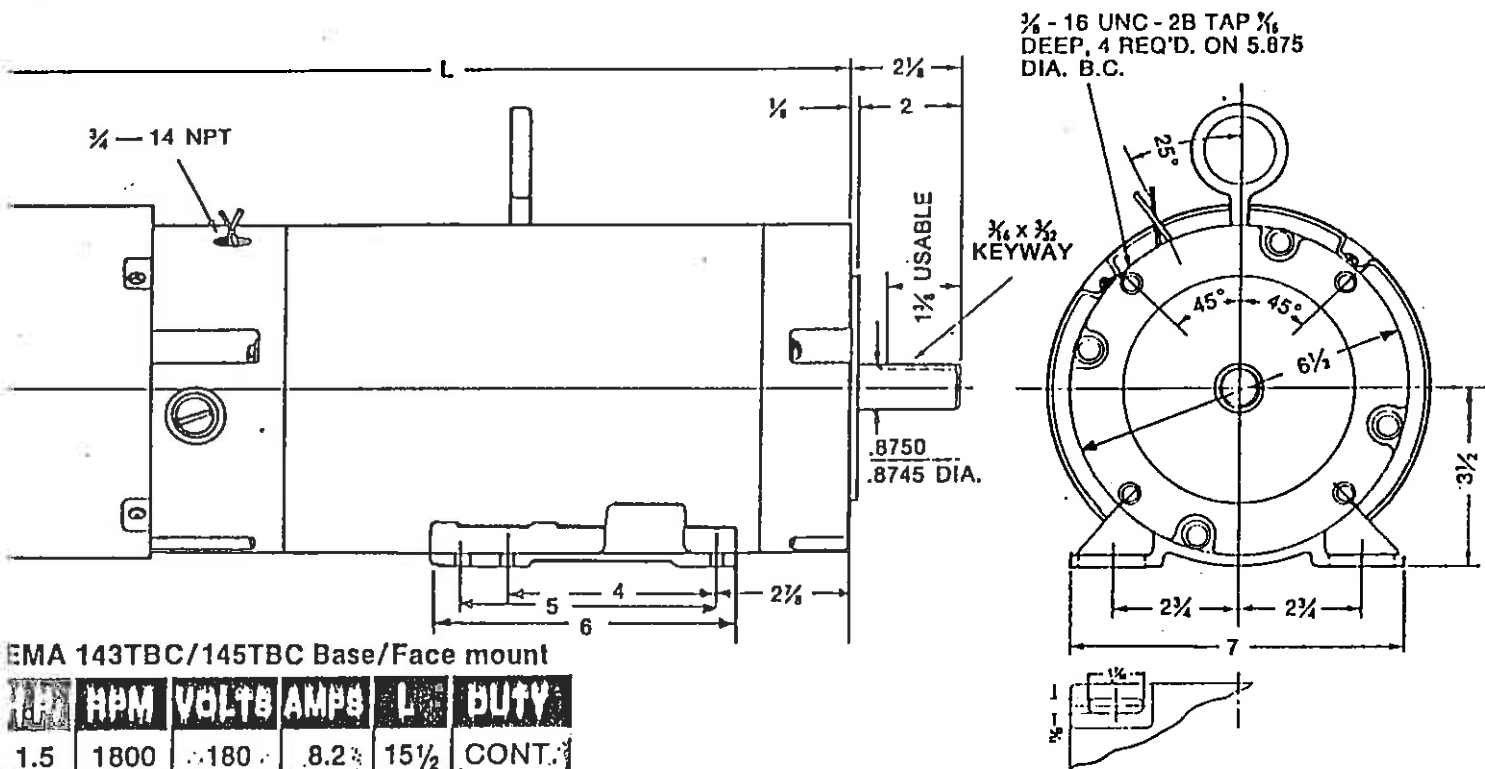

EMA 143TBC/145TBC Base/Face mount

H.P.	RPM	VOLTS	AMPS	L	DUTY
1.5	1800	180	8.2	$15\frac{1}{2}$	CONT.
	1800	180	11.6	$16\frac{1}{2}$	CONT.

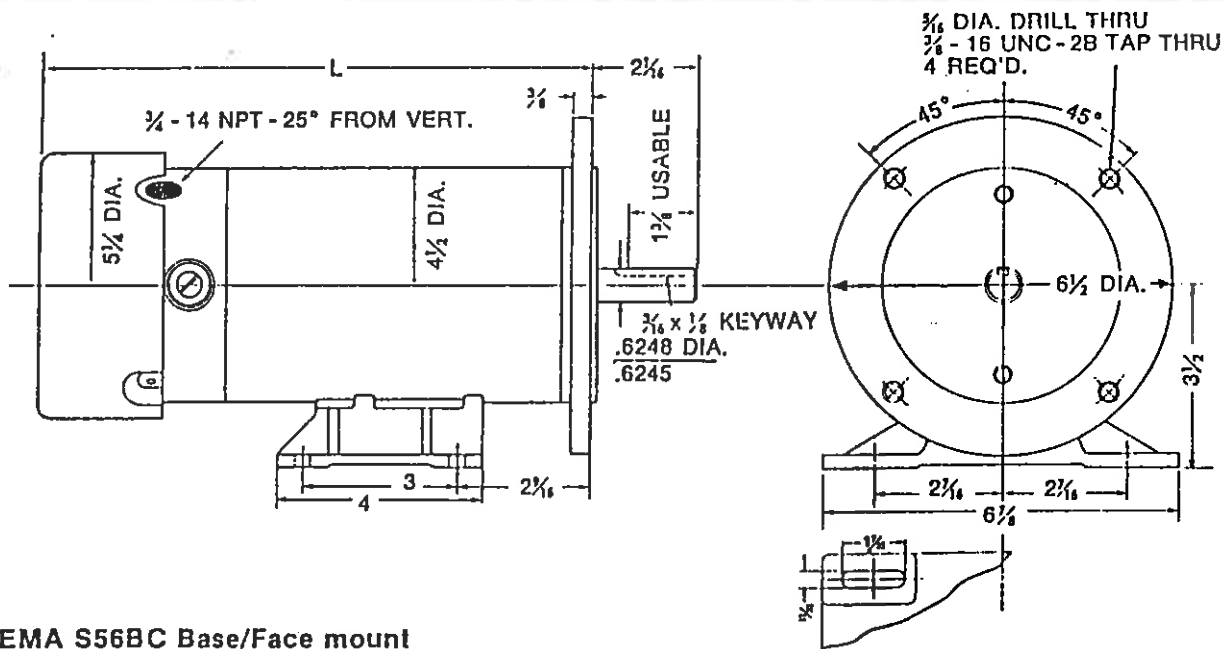

NEMA S56BC Base/Face mount

180 V.

H.P.	RPM	VOLTS	AMPS	L	DUTY
$\frac{1}{2}$	1725	180	2.8	$10\frac{3}{4}$	CONT.
$\frac{3}{4}$	1725	180	3.5	$12\frac{3}{4}$	CONT.
1	1725	180	5.35	$14\frac{3}{4}$	CONT.

90 V.

H.P.	RPM	VOLTS	AMPS	L	DUTY
$\frac{1}{2}$	1725	90	5.35	$10\frac{3}{4}$	CONT.
$\frac{3}{4}$	1725	90	8.1	$12\frac{3}{4}$	CONT.
1	1725	90	10.6	$14\frac{3}{4}$	CONT.

Lubrication

REDUCERS MAY BE FILLED TO THE PROPER OIL LEVEL AT THE FACTORY WITH AGMA No. 8 compounded oil. AFTER INSTALLATION OF THE WEATHER PLUG, UNIT IS READY FOR USE. Before installing breather plug, refer to instruction tag and determine proper position according to reducer mounting.

We recommend an initial oil change after 250 hours of operation, then every six months or every 500 hours of service under Class I Service. If actual operating temperatures, humid, dirty or corrosive environment, oil changes should be made more frequently. Frequency can be established by oil sample analysis.

KEEP YOUR OIL CLEAN

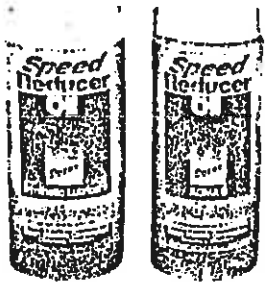

Loerr Electric replacement oil

To order oil, request:

Loerr part no. 00019001 — synthetic AGMA #7EP (-40°F to 150°F)

Loerr part no. 00019101 — AGMA #8 (50°F to 125°F)

Oil is packed 12 one quart bottles per carton, minimum ship one carton.

Contact DEC Service Dept. for order information.

OIL CAPACITIES*

UNIT TYPE	UNIT SERIES				
	133	175	208	282	325
Worm Over	14	20	27	49	84
Worm Under	17	22	28	49	73
Vertical Output	10	15	20	37	63
"J" Mount	13	18	23	38	63

*Capacities in approximate ounces. On double reduction units determine capacity of both primary and secondary reducers.

OIL LEVELS*

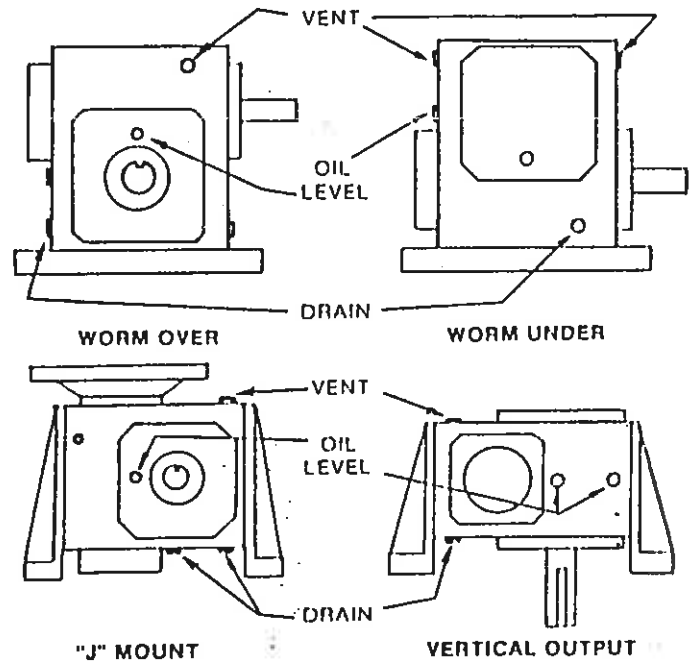

*On double reduction units fill and vent each unit to levels shown.

Electrical Boards' Chart for ORION Stretchwrappers

	168-4	168-A	236	336	750+	750M-240y	850M	850C	155-3A
MLH 44 Processor	X		X		X				
MLH 44	X		X		X				X
MLH 55		X		X			X		X
MLH 66		X		X			X		X
MLH 77		X							X
PA 33	X			X	X				
FA 33	X			X		X		X	
MA 33	X			X		X		X	
MA 44	X			X	X			X	
MA 55	X			X			X	X	

INB

COM

INA

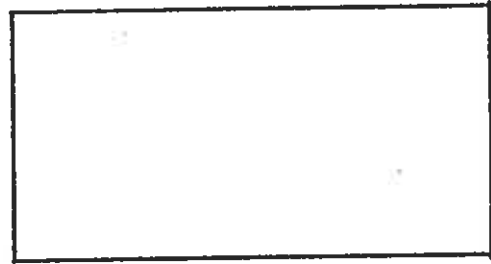
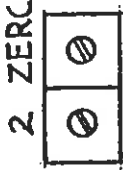
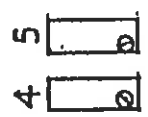
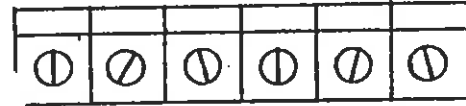

F1
AC2
AC1
F2
AZ
AI

ZERO: TURNTABLE DEADBAND ADJ.

1: HIGH SPEED ADJ.

2: JOG SPEED ADJ.

3: LOW SPEED ADJ.

4: HIGH SPEED DECELERATION ADJ.

5: LOW SPEED DECELERATION ADJ.

6: ACCELERATION ADJ.

7: LOAD RANGE ADJ.

8: CURRENT LIMITER

ORION PACKAGING INC.

ÉCHELLE: N.T.S. -
SCALE:

APPROUVÉ PAR:
APPROVED BY:

DESSINÉ PAR: VALENTINI
DRAWN BY:

DATE: 16 - 09 - 87

REVISE PAR:
REVISED BY:

750M + 233

NUMERO DE DESSIN
DRAWING NUMBER

200 888

- 168-4

DC -

DC +

AC 2

AC 1

1

ORION PACKAGING INC.

ÉCHELLE:
SCALE:

N.T.S.

APPROUVE PAR:
APPROVED BY:

DESSINE PAR: VALENTINI
DRAWN BY:

DATE: 16-9-87

REVISE PAR:
REVISED BY:

168-4

NUMERO DE DESSIN
DRAWING NUMBER

200 892



MAINTENANCE INSTRUCTIONS

STANDARD REDUCERS SERIES 133, 175, 206, 262, 325

INDEX

	Page
Introduction	1
Equipment Required	1
General Instructions	1
Housings	1
Seals	1
To Change Output Shaft Direction	1
Unit Disassembly, Parts Service, and Reassembly	1
Disassembly	1
Low Speed Shaft Removal	1
High Speed Shaft Removal	1, 2
Parts Service	2
Housing	2
Seal Cages and End Cover	2
Air Vent	2
Seals	2, 3
Bearings	3
Worm Gear and Shaft	3
Unit Reassembly	4
High Speed Shaft Assembly	4
Low Speed Shaft Assembly	4
Preventive Maintenance	6
Stored and Inactive Units	6
Parts Ordering Instructions	6
Exploded Views	7, 8, 9
Parts List	9
Warranty	Back Cover

- B. Remove internal snap ring from housing bore.
- C. Reposition the housing with the worm shaft horizontal. Using a plastic hammer gently tap on the end of the shaft extension to feed worm shaft assembly through housing and out.

Parts Service:

1. **Housing** — Clean inside of housing with kerosene or solvent and then dry.
2. **Seal cages and end cover** — Remove dirt from joint faces, wipe clean and dry.
3. **Air vent** — Wash in kerosene, blow clean and dry.
4. **Seals** — To replace seals without dismantling reducer refer to steps C through F below. To replace seals when the entire reducer is dismantled and coupling hubs, sprockets, pulleys, pinions, keys, etc. have been removed the following instructions apply:

NOTE: Replacement of all seals is recommended when a unit is disassembled.

Caution

New seals will leak if the seal lips or if seal's rubbing surface on the shaft has been altered. Protect seal lips at all times. Clean the shaft but do not use any abrasive material on the shaft surface polished by the seal.

- A. Block up seal cages and press or drive out seal.
- B. Remove old sealing compound from seal seat in cage if it is present. If a seal with rubber coating on the outside diameter is used, no Permatex is necessary. If no rubber coating is on seal outside diameter, coat seal cage bore with Permatex No. 3 or equivalent immediately before assembly. To prevent possible damage to seal lips, do not reassemble seals until high speed and low speed shafts have been reassembled to the housing. Then see steps E and F below.
- C. See Figures 1 through 4—To replace seals without dismantling reducer, proceed as follows:

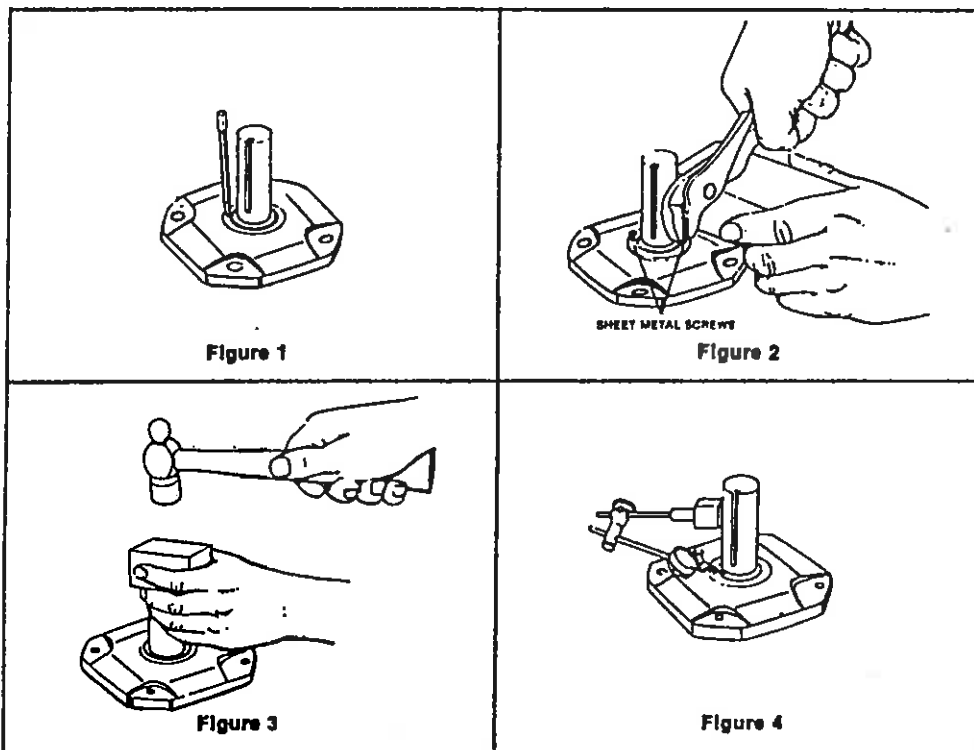

Caution

Do not damage shaft; new seals will leak if seal contacting surface is marred. Use punch and place two or more holes in steel casing of seal, Figure 1. (The steel casing may be rubber coated) Insert sheet metal screws, leaving the heads sufficiently exposed so they can be pried up or grasped with pliers, Figure 2. Do not drill holes because chips may get into the unit.

- D. Work seal loose. Be careful to keep all metal or dirt particles from entering unit. Remove old sealing compound from seal seat if it is present. Also remove burrs and sharp edges from shaft. Clean with rag moistened with solvent. Do not use abrasive material on shaft seal contacting surface.

Caution

E. Protect seal lips when handling; seal leakage will result if these are damaged. If a seal with rubber coating on the outside diameter (O.D.) is used, no Permatex is necessary. If no rubber coating is on seal O.D., coat seal cage bore with Permatex No. 3 or equivalent. Coat seal lips with oil and carefully work seal into position. Before sliding seal into position, protect seal lips from shaft keyway edges by wrapping shaft with thin, strong paper coated with oil. Position garter spring toward the inside of the unit. Place a square faced pipe or tube against the seal O.D. and drive or press seal until fully seated as shown in Figure 3. Do not strike seal directly.

- F. For best performance, seat the seal square with shaft within .005" at 180°. Check with dial indicator as shown in Figure 4, Page 2, or with a straight edge and feelers, or square and feelers. To straighten a cocked seal, place tubing over the seal and tap the tube lightly at a point diametrically opposite the low point on the seal. DO NOT strike seal directly.

5. Bearings —

- A. Wash all bearings in clean kerosene and then dry.
B. Inspect bearings carefully and replace those that are worn or questionable.
NOTE: Replacement of all bearings is recommended.
C. Use a wheel puller or press to remove worm shaft bearings. Apply force to inner race only — not to cage or outer race.
D. Use a wheel puller or press to remove output bearing inner races.
E. New seal cages and end covers must be used when replacing output bearings. Output bearing outer races must be pressed in square and seated completely.
F. To replace output bearing inner races and all input bearings, heat bearings in an oil bath or oven to maximum of 290 degrees F (143 degrees C). Slide high speed shaft bearings onto the oiled shaft until seated against the shoulder or snap ring of the shaft. Slide low speed shaft bearings onto the oiled shaft against the gear spacer.
G. Thoroughly coat all bearings with lubricating oil.

6. Worm, gear and shafts

- A. Worm and high speed shaft—since all worms are integral with the high speed shaft, any wear or damage to the worm will necessitate replacing both.
B. Press shaft out of bronze worm gear. To reassemble gear and low speed shaft, freeze shaft or heat gear. Do not exceed 200 degrees F (93 degrees C). Insert key into shaft keyway and press shaft into oiled gear bore. The short hub of the gear must be assembled toward snap ring on the shaft.
NOTE: It is advisable to replace both the worm and worm gear should either of the assemblies require replacement.

Unit Reassembly:

1. Preliminary

- A. Check to see that all worn parts have been replaced, gear and bearings coated with oil and all parts cleaned. Remove all foreign matter from unit feet. The feet must be flat and square with each other.
- B. Before starting to reassemble reducer, add old shims or replace with new shims of equal thickness.

2. High Speed Shaft (Worm Shaft) Assembly

- A. Lubricate bearing bores of housing and insert high speed shaft sub-assembly from opposite extension end into housing until seated against shoulder in bore. Tap the end of the shaft lightly with a plastic hammer to feed bearings through bores.
- B. Lock high speed sub-assembly in housing bore with lock ring.
- C. Coat outside diameter of stamped steel end cover with Permatex No. 2 and press into high speed bore opposite extension end until flush with housing. If steel endcover is rubber coated then no Permatex is necessary.

3. Low Speed Shaft (Gear Shaft) Assembly

- A. Determine output shaft direction.
- B. Assemble low speed shaft assembly, seal cage, and end cover with shims on both seal cage and end cover. Torque cap screws to torques listed in Table 1. Rotate the input shaft to seat output bearings.
- C. Moving the shaft back and forth by hand, check axial float with dial indicator as shown in Figure 5. Axial float must be .0005-.003 with .0005 being the absolute minimum. Do not preload bearings. If the axial float is not as specified add or subtract required shims under end cover.

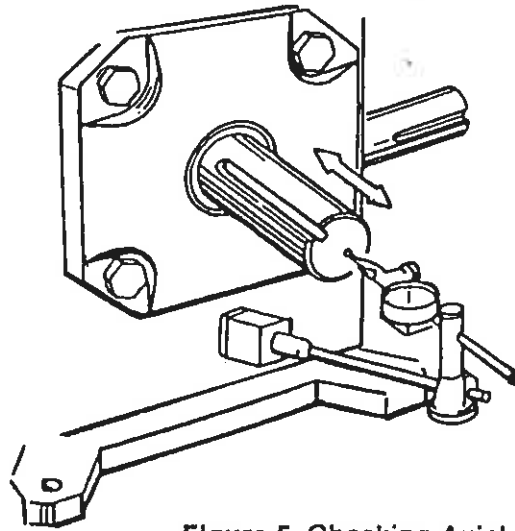

Figure 5 Checking Axial Float

- D. Remove output shaft with seal cage and apply bluing to entire worm thread. Worm thread must be clean of oil. Reassemble output shaft and seal cage with output key facing up.
- E. Use a rag to apply hand pressure to the output shaft and rotate the high speed shaft until output key is down. Return output shaft to original position by reversing rotation. Remove output shaft and seal cage to inspect contact. Compare with Figure 6. If contact is not correct move assembly in the direction shown in Figure 6 by adding shims to the side to which the arrow points after removing them from the opposite side. Repeat steps D and E until contact pattern is correct.
- F. Recheck axial float with dial indicator.
- G. When contact pattern is correct tighten seal cage and end cover cap screws to torques listed in Table 1 page 1.

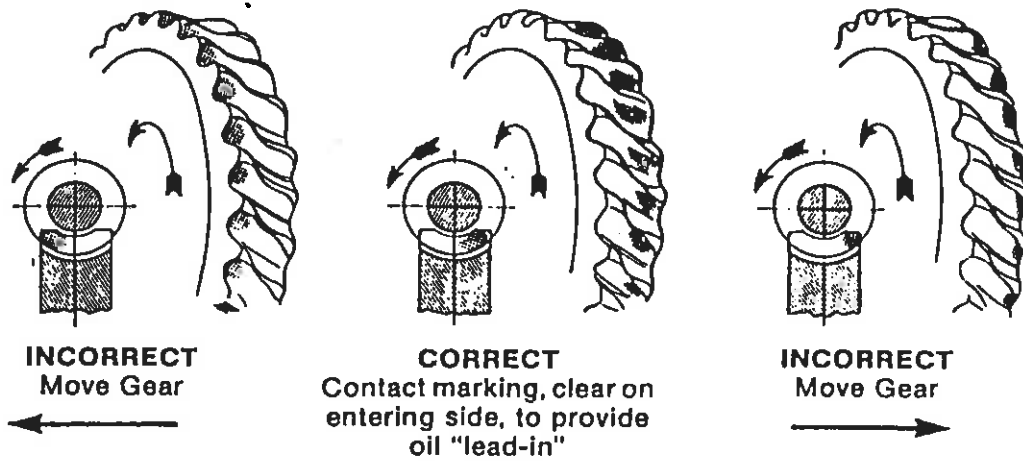

Figure 6 Gear Contact Pattern

4. **Seals** — To reassemble seals to unit, see Parts Service Steps 4E and 4F, page 3.

5. **Motorized Coupling Adaptor**

Certain mounting dimensions should be adhered to when removing motor and coupling assembly for service. When ordering replacement coupling halves (metal gear), specify correct bore diameter. See Table 2 for mounting dimensions and available bore sizes.

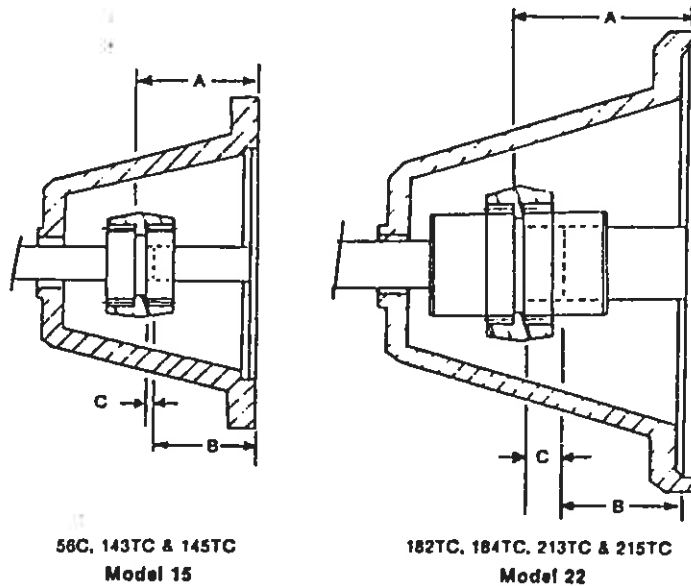

Figure 7 Motorized Coupling Adaptor

TABLE 2. COUPLING ADAPTOR DATA

"C" COUPLING MOUNTING DATA

N.E.M.A. Frame No.	Mounting Dimensions		
	Reducer A ± 1/64	Motor B ± 1/64	C
56C	2 5/16	2 1/16	1/16
143TC	2 5/16	2 1/8	—
145TC	2 5/16	2 1/8	—
182TC	3 5/16	2 5/8	1/2
184TC	3 5/16	2 5/8	1/2
213TC	3 5/16	3 1/8	—
215TC	3 5/16	3 1/8	—

BORE SIZES AVAILABLE

MODEL 15		MODEL 22	
Bore	Kwy.	Bore	Kwy.
.500	None	—	—
.500	1/8 x 1/16	—	—
.625	3/16 x 3/32	.625	3/16 x 3/32
.750	3/16 x 3/32	.750	3/16 x 3/32
.875	3/16 x 3/32	.875	3/16 x 3/32
—	—	1.125	1/4 x 1/8
—	—	1.375	3/16 x 3/32

6. Final Inspection

- A. Turn gear train over by hand as a final check.
- B. Re-install reducer and accessories.

CAUTION: Discard motor key. Use only special key provided with reducer. Failure to use special key will make assembly impossible.

- C. Fill reducer with the recommended oil to proper level. See Fig. 8 for standard oil levels. (Type of oil recommended — see nameplate).
- D. Spin test for three minutes and check for noise, leakage, and rapid temperature rise.

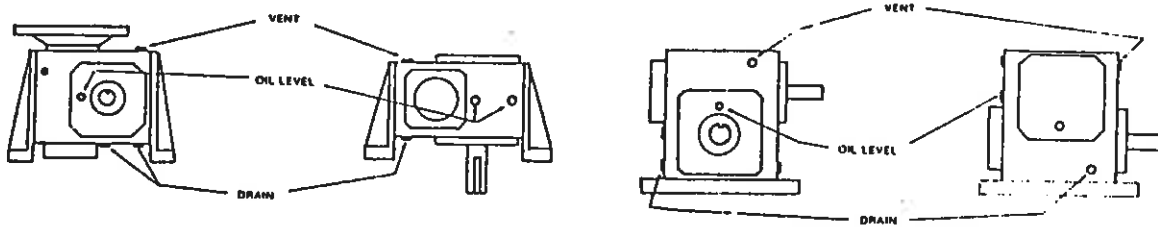

Figure 8 Standard Oil Levels

PREVENTATIVE MAINTENANCE

- A. After first week check all external cap screws and plugs for tightness.
- B. Periodically, check oil level when gears are at rest. Add oil if needed. Do not fill above mark indicated by level because leakage and overheating may occur.
- C. Oil changes — For normal operating conditions, change oil every six months or 2500 hours, whichever occurs first. Also if the unit is operated in an area where temperatures vary with the season, change the oil viscosity to suit the temperature. Most lubricant suppliers can test oil periodically and recommend economical oil change schedules.

CAUTION

See nameplate for type of lubricant to be used.

STORED AND INACTIVE UNITS

1. Each unit is shipped with oil that will protect parts against rust for a period of 4 months in an outdoor shelter or 12 months in a dry building after shipment from the factory. Indoor dry storage is recommended.
2. If a unit is to be stored or is to be inactive after installation beyond the above periods, fill the unit completely with oil.

CAUTION

Before starting a stored unit or re-starting an inactive unit, the oil level should be returned to the proper value as indicated by the oil level.

PARTS ORDERING INSTRUCTIONS

When ordering replacement parts first locate the exploded view that corresponds to your Doerr Electric gear reducer. Then determine which parts must be ordered. To order the parts, please provide the following:

1. Complete Model Number (Nameplate)
2. Item Number (Exploded view and parts list)
3. Part Description (Parts list)

Note that one parts list covers all five exploded views. Although a single item number may refer to the same part on all five exploded views, it is incorrect to assume that these parts are interchangeable. They are not. Therefore, it is imperative that items 1 through 3 above be provided when ordering your parts.

Failure to provide this information will only slow or prevent the processing of your order.

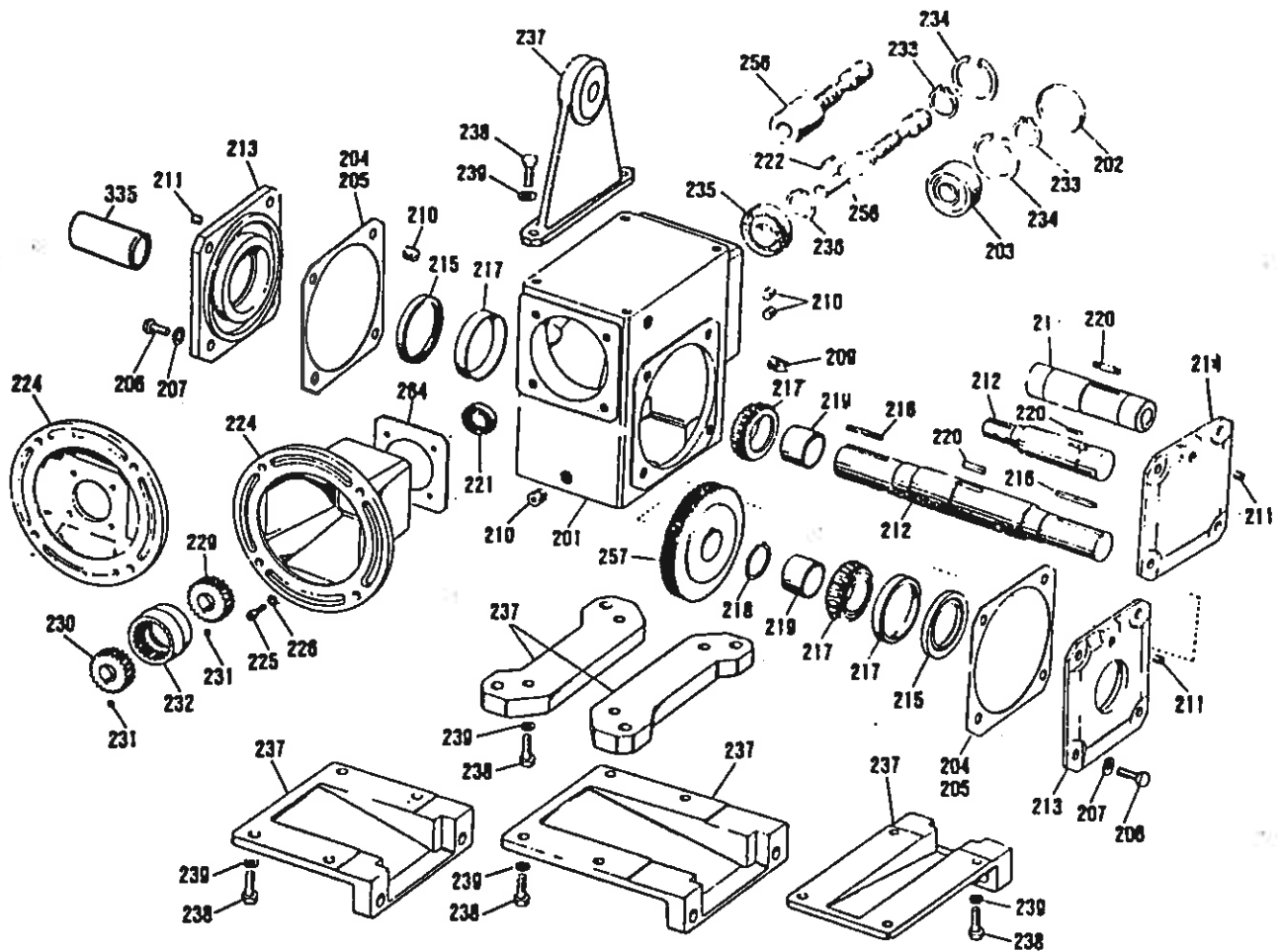

Single Reduction Unit 133, 175, 206 Series

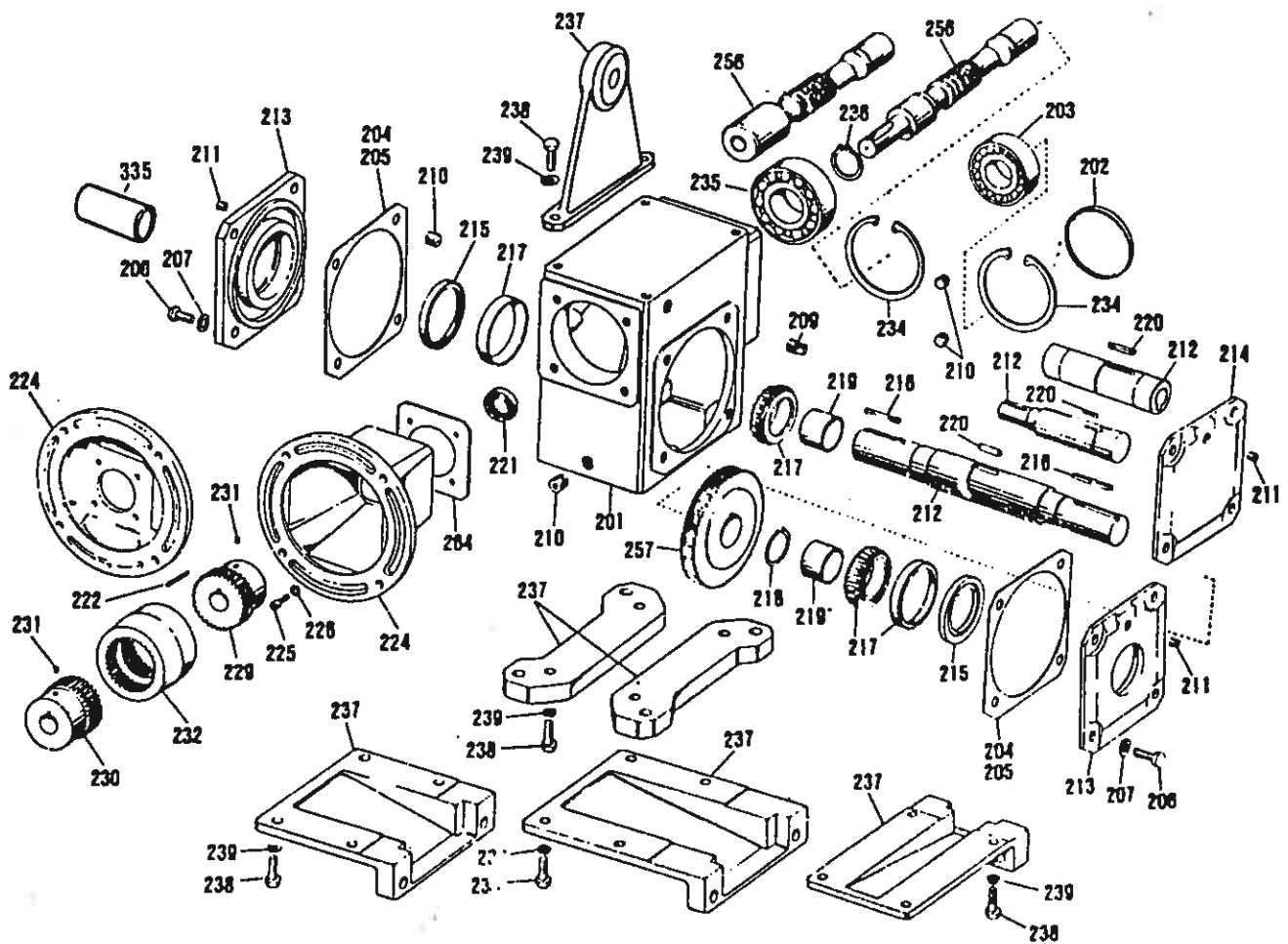

Single Reduction Unit 262, 325 Series

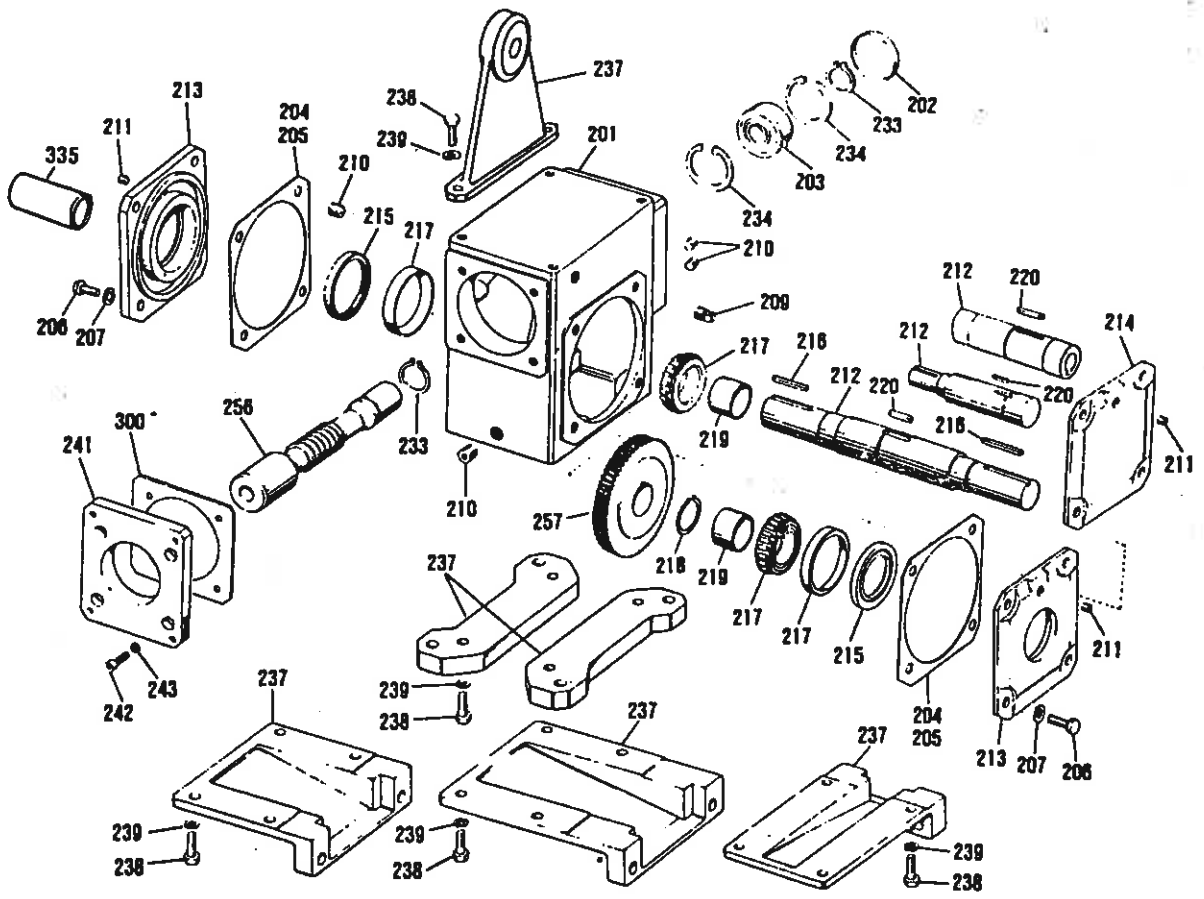

Double Reduction Secondary Unit 133, 175, 206 Series

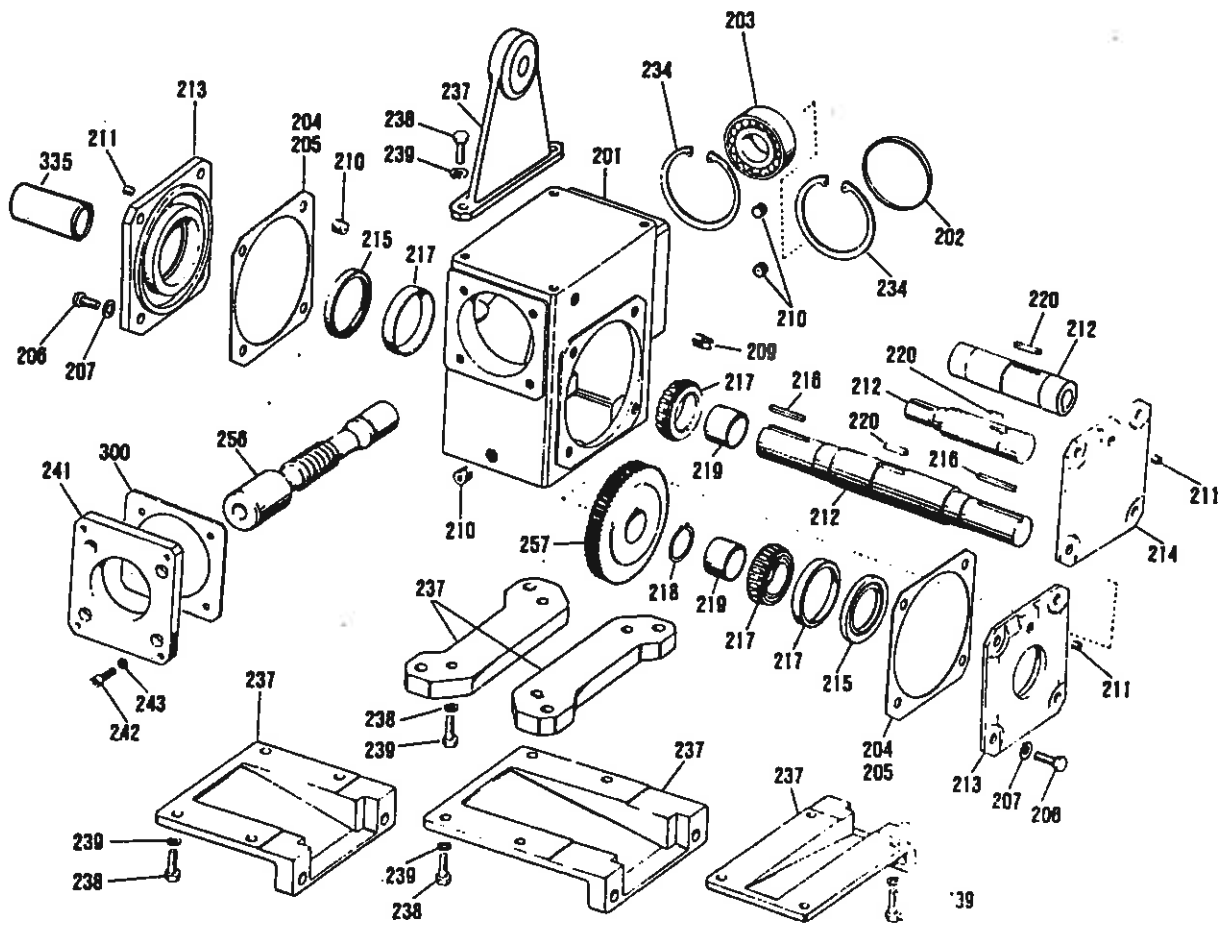

Double Reduction Secondary Unit 262, 325 Series

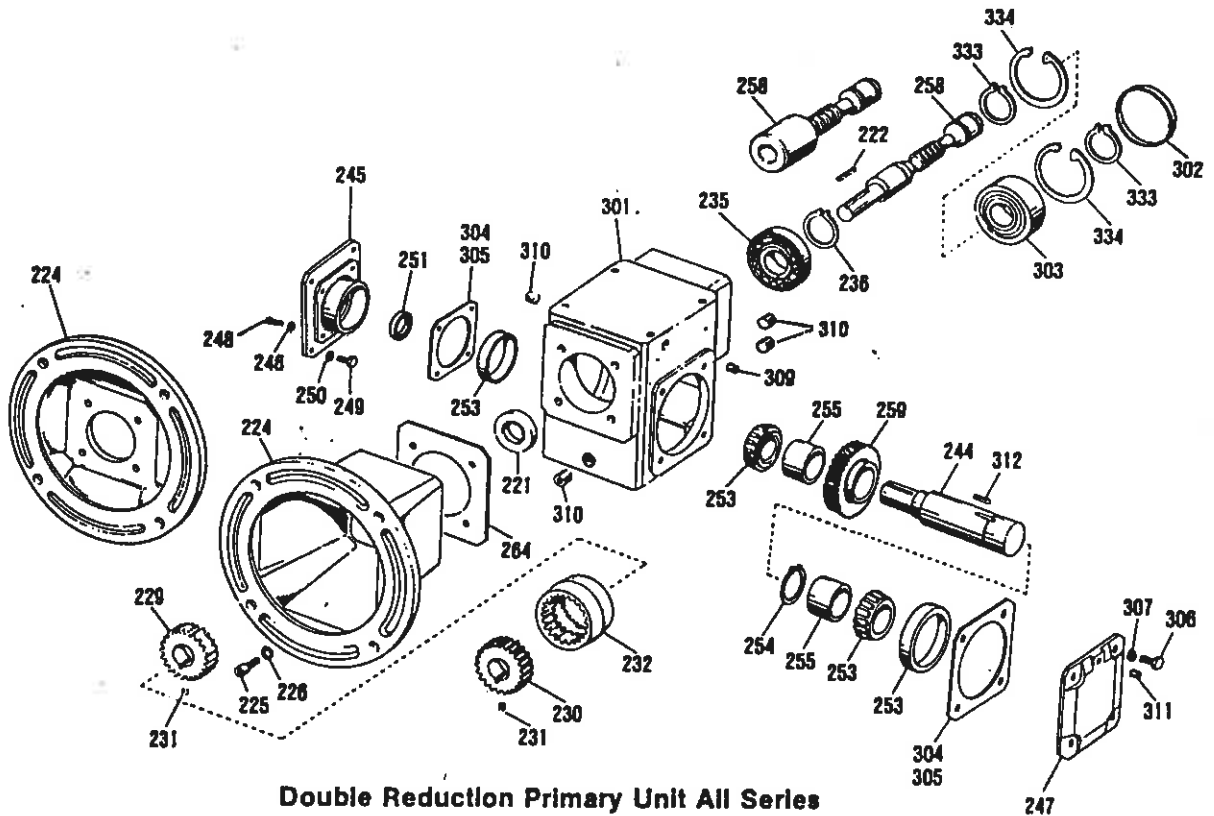

Double Reduction Primary Unit All Series

PARTS LIST
(Applies to all exploded views)

ITEM	DESCRIPTION	ITEM	DESCRIPTION	ITEM	DESCRIPTION
201	Housing	229	Coupling Hub (Unit)	255	Spacer
202	End Cover	230	Coupling Hub (Motor)	256	Worm
203	Bearing	231	Setscrew	257	Gear
204	Shim (.019 Thick)	232	Coupling Sleeve	258	Worm
205	Shim (.007 Thick)	233	Lock Ring	259	Gear
206	Capscrew	234	Lock Ring	260	Thrust Plate
207	Lock Washer	235	Bearing	261	Capscrew
209	Vent Plug	236	Lock Ring	264	Gasket
210	Pipe Plug	237	Base	300	Gasket
211	Pipe Plug	238	Capscrew	301	Housing
212	Output Shaft	239	Lock Washer	302	End Cover
213	Seal Cage	241	Secondary Adaptor	303	Bearing
214	End Cover	242	Capscrew	304	Shim (.019 Thick)
215	Oil Seal	243	Lock Washer	305	Shim (.007 Thick)
216	Key	244	Primary Output Shaft	306	Capscrew
217	Bearing	245	Primary Adaptor	307	Lock Washer
218	Lock Ring	246	Lock Washer	309	Vent Plug
219	Spacer	247	End Cover	310	Pipe Plug
220	Key	248	Capscrew	311	Pipe Plug
221	Oil Seal	249	Capscrew	312	Key
222	Key	250	Lock Washer	333	Lock Ring
224	Motor Flange	251	Oil Seal	334	Lock Ring
225	Capscrew	253	Bearing	335	Shaft Cover
226	Lock Washer	254	Lock Ring		

Note: When ordering replacement parts, specify model number, item number, and part description.